



■ Product description:

- The AH10VSO , variable pump in axial piston swash plate design for hydrostatic drives in an open circuit, is designed for stationary applications.
- The AH10VO , variable pump in axial piston swash plate design for hydrostatic drives in an open circuit, is designed for mobile applications.
- The flow is proportional to the drive speed and the displacement. The flow can be steplessly varied by adjusting the swash-plate angle

■ Features:

- Excellent suction characteristics
- Permissible continuous operating pressure up to 28 MPa
- Axial and radial load capacity of drive shaft
- Short response time
- The through drive is suitable for adding gear pumps and axial piston pumps up to the same size
- Low noise and long service life
- Favorable power-to-weight ratio
- Versatile controller range

■ Applications:

- The Steel Metallurgy and Forging Machine
- Engineering Machinery and facility processing
- The Ships and Water Resources and Hydropower Hoist
- The Oil and Petrochemical Machinery
- Building and mobile machine

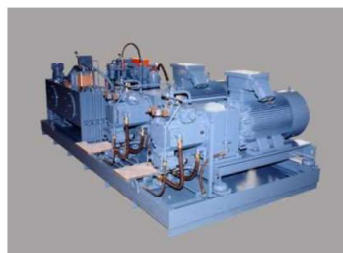

■ Type Code For Standard Program:

AH			10VS	O	100	DR	/	31	R	-	P	P	A	12	N00
0		1	2	3	4	5		6	7		8	9	10	11	12

0. Supplier:

ACCESSHYDRO

1. Hydraulic fluid version:

Hydraulic fluid/ Standard:	10	18	28	45	71	100	140	Code
Mineral oil.....no code	■	■	■	■	■	■	■	-
Flame retardant hydraulic fluid (HF) See details in Hydraulic Selection	-	-	■	■	■	■	■	E
High-speed version	-	-	-	□	□	□	■	H

2. Axial piston unit:

Axial piston unit / Version: :	10	18	28	45	71	100	140	
Swash plate design, variable, up to industrial grade	■	■	■	■	■	■	■	AH10VS
Size10: Nominal pressure 250 bar, Peak Pressure 315 bar. Size 18... 140: Nominal pressure 280 bar, Peak Pressure 350 bar.								

3. Type of operation:

Type of operation / Version:	10	18	28	45	71	100	140	Code
Pump, open circuit	■	■	■	■	■	■	■	O

4. Size:

Size / Version:	10	18	28	45	71*	100	140	Code
Size \cong Vgmax (cm ³ /r)	10	18	28	45	71	100	140	-

5. Control devices:

Control devices / Version:		10	18	28	45	71	100	140	Code
Two-point control, directly operated		-	■	■	■	■	■	■	DG
Pressure control		■	■	■	■	■	■	■	DR
pressure control...remotely operated		■	■	■	■	■	■	■	DRG
Flow control		■	■	■	■	■	■	■	DFR
Pressure and Flow control, X-T plugged		■	■	■	■	■	■	■	DFR1
Pressure, flow and power control		■	■	■	■	■	■	■	DFLR
Electro-flow control...with swash-plate position feedback		-	-	□	□	□	□	□	FE1
Flow/Pressure electronic control		-	□	□	□	□	□	□	DFE1
Electro -hydraulic pressure control	negative characteristic	12V	-	□	□	□	□	□	ED71
			24V	-	□	□	□	□	ED72
	positive characteristic	12V	-	□	□	□	□	□	ER71
		24V	-	□	□	□	□	□	ER72

■ Type Code For Standard Program:

6. Series:

Series / Version:	10	18	28	45	71	100	140	Code
Series 31	-	■	■	■	■	■	■	31
Series 52	■	-	-	-	-	-	-	52

7. Direction of rotation:

Direction of rotation:	Direction of rotation	Code
With view on drive shaft	Clockwise(forward dextral)	R
	Counter-clockwise (reverse left-handed)	L

8. Seals:

Seals / Version:	10	18	28	45	71	100	140	Code
NBR (Nitri-caoutchouc to DIN ISO 1629, with shaft seal FKM)	■	■	■	■	■	■	■	P
FKM (fluor-caoutchouc to DIN ISO 1629)	■	■	■	■	■	■	■	V

9. Shaft end:

Shaft end / Version:	10	18	28	45	71	100	140	Code
Keyed parallel shaft to DIN 6885	■	■	■	■	■	■	■	P
Splined shaft SAE ANSI B92.1a	not for through drive	■	■	■	■	■	■	P
	standard shaft	■	■	■	■	■	■	S
	similar to shaft S , however for higher input torque	-	■	■	■	■	-	-
reduced diameter, not for through drive	■	-	-	-	-	-	-	U

10. Mounting flange:

Mounting flange / Version: :	10	18	28	45	71	100	140	Code	
ISO 3019-2 DIN	2-hole	■	■	■	■	■	■	-	A
	4-hole	-	-	-	-	-	-	■	B
ISO 3019-1 SAE	2-hole	■	-	-	-	-	-	-	C

11. Service line port:

Service line port / Version:	10	18	28	45	71	100	140	Code
Port B and S at rear of opposite sides SAE flange port , metric fixing thread	-	■	■	■	-	■	■	12
Port B and S at rear of opposite sides SAE flange port , metric fixing thread	-	-	-	-	■	-	-	42
Port B and S at rear Metric threaded ports, not for through drive	■	-	-	-	-	-	-	14

■ Type Code For Standard Program:

12. Through drive:

Through drive / Version:			10	18	28	45	71	100	140	Code
Without through drive			■	■	■	■	■	■	■	N00
With through drive for mounting an axial piston unit, gear, or radial piston pump										
Flange	Coupling for splined shaft		10	18	28	45	71	100	140	Code
Flange ISO 3019-1			ANSI B92.1a							
82-2 (A)	5/8"	9T 16/32 DP	-	■	■	■	■	■	■	K01
	3/4"	11T 16/32 DP	-	■	■	■	■	■	■	K52
101-2 (B)	7/8"	13T 16/32 DP	-	-	■	■	■	■	■	K68
	1"	15T 16/32 DP	-	-	-	■	■	■	■	K04
127-2 (C)	1-1/4"	14T 12/24 DP	-	-	-	-	■	■	■	K07
	1-1/2"	17T 12/24 DP	-	-	-	-	-	■	■	K24
152-4 (D)	1-3/4"	13T 8/16 DP	-	-	-	-	-	-	■	K17
Φ63 metric 4-hole	shaft key	Φ25	-	-	■	■	■	■	■	K57
Flange ISO 3019-1			ANSI B92.1a							
ISO 80 2-hole	3/4"	11T 16/32 DP	-	■	■	■	■	■	■	KB2
ISO 100 2-hole	7/8"	13T 16/32 DP	-	-	■	■	■	■	■	KB3
	1"	15T 16/32 DP	-	-	-	■	■	■	■	KB4
ISO 125 2-hole	1-1/4"	14T 12/24 DP	-	-	-	-	■	■	■	KB5
	1-1/2"	17T 12/24 DP	-	-	-	-	-	■	■	KB6
ISO 180 2-hole	1-3/4"	13T 8/16 DP	-	-	-	-	-	-	■	KB7

 = Preferred scenario (short available time)

 = available

 = on request

- = not available

■ Technical data... Size10 Series 52:

- Applies to mineral oil medium run
- Operating pressure range:
- Pressure at service line port (pressure port) B:
Nominal pressure P_{nom} 250 bar
Peak pressure P_{max} 315 bar
- Single operating period 2.5 ms, Total operating period 300 h
- Minimum pressure (high-pressure side): 10 bar absolute
- Rate of pressure change $R_{A,max}$: 16000 bar/s

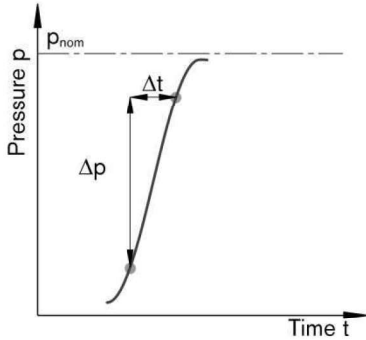

- Pressure at suction port S (inlet):
Minimum pressure $P_{S,min}$ 0.8 bar...absolute
Maximum pressure $P_{S,max}$ 5 bar ...absolute
- Case drain pressure:
- The lower the input speed and the case drain pressure, the longer the service life of the shaft end seal.
- Maximum permissible case drain pressure (at port L, L1)
Maximum 0.5 bar higher than the inlet pressure at port S, however not higher than 2 bar absolute.
 $P_{L,max}$ 2 bar... absolute
- Maximum permissible speed (limit speed)
- To determine the min.required inlet pressure P_{abs} at inlet port S or the reduction of displacement at higher input speeds, see the diagram below:

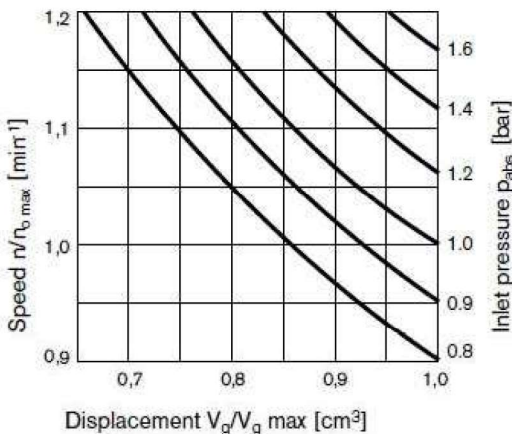

■ Technical data... Size18...140 Series 31

- Applies to mineral oil medium run
- Operating pressure range:
- Pressure at service line port (pressure port) B:
Nominal pressure P_{nom} 280 bar
Peak pressure P_{max} 350 bar
- Single operating period 2.5 ms, Total operating period 300 h
- Minimum pressure (high-pressure side): 10 bar absolute
- Rate of pressure change $R_{A,max}$: 16000 bar/s

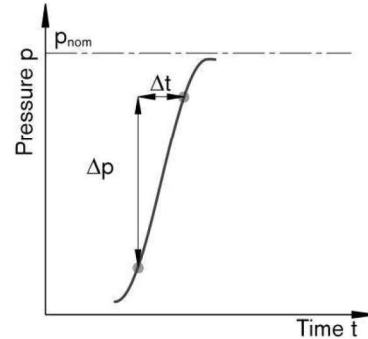

- Pressure at suction port S (inlet):
Minimum pressure $P_{S,min}$ 0.8 bar...absolute
Maximum pressure $P_{S,max}$ 10 bar
- Case drain pressure:
- The lower the input speed and the case drain pressure, the longer the service life of the shaft end seal.
- Maximum permissible case drain pressure (at port L, L1)
Maximum 0.5 bar higher than the inlet pressure at port S, however not higher than 2 bar absolute.
 $P_{L,max}$ 2 bar...absolute
- Definition:
- Nominal pressure P_{nom}
The nominal pressure corresponds to the maximum design pressure.
- Peak pressure P_{max}
The peak pressure corresponds the maximum operating pressure within the single operating period. The sum of the single operating periods must not exceed the total operating period.
- Minimum pressure (high-pressure side):
Minimum pressure on the high-pressure side (B) that is required in order to prevent damage to the axial piston unit.
- Rate of pressure change R_A
Maximum permissible rate of pressure build-up and pressure reduction during a pressure change over the entire pressure range.

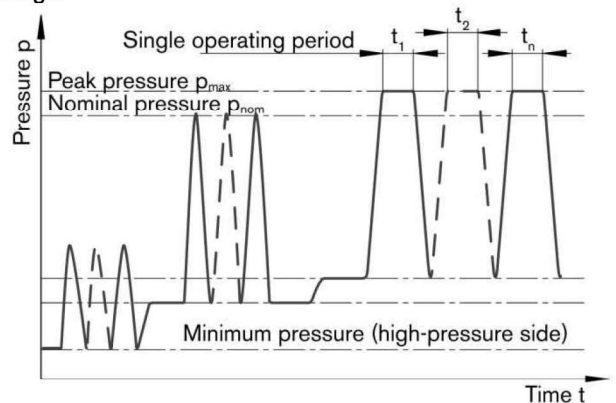

- Total operating period = $t_1 + t_2 + t_3 + \dots + t_n$

■ Technical data... Size10 Series 52:

□ Standard Program, applies to mineral oil medium run

□ Table of values: (theoretical values, without efficiencies and tolerances: values rounded)

Size	NG		10	
Geometrical displacement per revolution	$V_{g \max}$	cm ³	10.5	
Speed ³⁾				
maximum at $V_{g \max}$	n_{nom}	rpm	3600	
maximum at $V_g < V_{g \max}$	$n_{\text{max perm}}$	rpm	4320	
Flow				
at n_{nom} and $V_{g \max}$	$q_{v \max}$	l/min	37	
at $n_E = 1500$ rpm and $V_{g \max}$	$q_{vE \max}$	l/min	15	
Power at $\Delta p = 250$ bar				
at n_{nom} , $V_{g \max}$	P_{\max}	kW	16	
at $n_E = 1500$ rpm and $V_{g \max}$	$P_{E \max}$	kW	7	
Torque				
at $V_{g \max}$ and $\Delta p = 250$ bar	T_{\max}	Nm	42	
	T	Nm	17	
Rotary stiffness, drive shaft	S	c	Nm/rad	9200
	R	c	Nm/rad	–
	U	c	Nm/rad	6800
	W	c	Nm/rad	–
	P	c	Nm/rad	10700
Moment of inertia rotary group	J_{TW}	kgm ²	0.0006	
Angular acceleration, maximum ⁵⁾	α	rad/s ²	8000	
Filling capacity	V	L	0.2	
Weight (without through drive) approx.	m	kg	8	

□ Permissible radial and axial forces on the drive shaft

Size	NG		10
Radial force maximum at $a/2$	$F_{q \max}$	N	250
Axial force maximum	$+ F_{ax \max}$	N	400

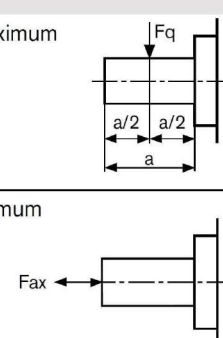

□ Permissible input and through drive torques

Size	NG		10
Torque at $V_{g \max}$ and $\Delta p = 250$ bar ¹⁾	T_{\max}	Nm	42
Input torque for drive shaft, maximum ²⁾			
S	$T_{E \max}$	Nm	126
	\emptyset	in	3/4
R	$T_{E \max}$	Nm	–
	\emptyset	in	–
U	$T_{E \max}$	Nm	60
	\emptyset	in	5/8
W	$T_{E \max}$	Nm	–
	\emptyset	in	–
P	$T_{E \max}$	Nm	90
	\emptyset	mm	18
Maximum through-drive torque for drive shaft			
S	$T_{D \max}$	Nm	–
R	$T_{D \max}$	Nm	–

■ Technical data... Size18...140 Series 31

□ Standard Program, applies to mineral oil medium run

□ Table of values: (theoretical values, without efficiencies and tolerances: values rounded)

Size	NG	Size	18	28	45	71	100	140
Geometrical displacement per revolution								
	$V_{g \max}$ cm ³		18	28	45	71	100	140
Speed ¹⁾								
	maximum at $V_{g \max}$	n_{nom} rpm	3300	3000	2600	2200	2000	1800
	maximum at $V_g < V_{g \max}$	$n_{\text{max perm}}$ rpm	3900	3600	3100	2600	2400	2100
Flow								
	at n_{nom} and $V_{g \max}$	$q_{v \max}$ l/min	59	84	117	156	200	252
	at $n_E = 1500$ rpm and $V_{g \max}$	$q_{vE \max}$ l/min	27	42	68	107	150	210
Power at $\Delta p = 280$ bar								
	at n_{nom} , $V_{g \max}$	P_{max} kW	30	39	55	73	93	118
	at $n_E = 1500$ rpm and $V_{g \max}$	$P_{E \max}$ kW	12.6	20	32	50	70	98
Torque								
	at $V_{g \max}$ and $\Delta p = 280$ bar	T_{max} Nm	80	125	200	316	445	623
	$\Delta p = 100$ bar	T Nm	30	45	72	113	159	223
Rotary stiffness, drive shaft								
	S	c Nm/rad	11087	22317	37500	71884	121142	169537
	R	c Nm/rad	14850	26360	41025	76545	–	–
	P	c Nm/rad	13158	25656	41232	80627	132335	188406
Moment of inertial rotary group		J_{TW} kgm ²	0.00093	0.0017	0.0033	0.0083	0.0167	0.0242
Angular acceleration, maximum ²⁾		α rad/s ²	6800	5500	4000	3300	2700	2700
Filling capacity		V L	0.4	0.7	1.0	1.6	2.2	3.0
Weight (without through drive) approx.		m kg	12	15	21	33	45	60

1) The values are applicable:

- ✚ for absolute pressure $P_{\text{abs}} = 1$ bar at the suction port S;
- ✚ for the optimum viscosity range of $V_{\text{opt}} = 16$ to 36 mm²/s
- ✚ for mineral-based operating materials

2) The scope of application lies between the minimum necessary and the maximum permissible drive speeds;

- ✚ Valid for external excitation;
- ✚ The limiting value is only valid for a single pump;
- ✚ The loading capacity of the connecting parts must be taken into account.
- ✚ If the drive speed continuous increasing and up to the limit speed, please conform to the curves shows.

□ Notes:

✚ Exceeding the maximum or falling below the minimum permissible values can lead to a loss of function, a reduction in operational service life or total destruction of the axial piston unit.

✚ We recommend checking the loading with tests or calculations / simulations and comparison with the permissible values.

□ Determination of size:

Flow	$q_v = \frac{V_g \cdot n \cdot \eta_v}{1000}$	[l/min]	V_g = Displacement per revolution in cm ³
			Δp = Differential pressure in bar
Torque	$T = \frac{V_g \cdot \Delta p}{20 \cdot p \cdot h_{mh}}$	[Nm]	n = Speed in rpm
			η_v = Volumetric efficiency
Power	$P = \frac{2\pi \cdot T \cdot n}{60000} = \frac{q_v \cdot \Delta p}{600 \cdot \eta_t}$	[kW]	η_{mh} = Mechanical-hydraulic efficiency
			η_t = Total efficiency ($\eta_t = \eta_v \cdot \eta_{mh}$)

■ Technical data... Size18...140 Series 31:

□ High- speed version, applies to mineral oil medium run

□ Table of values: (theoretical values, without efficiencies and tolerances: values rounded)

Size	NG		45	71	100	140	
Geometrical displacement per revolution		$V_{g \max}$ cm ³	45	71	100	140	
Speed ¹⁾							
	maximum at $V_{g \max}$	n_{nom} rpm	3000	2550	2300	2050	
	maximum at $V_g < V_{g \max}$	$n_{\text{max perm}}$ rpm	3300	2800	2500	2200	
Flow							
	at n_{nom} and $V_{g \max}$	$q_{v \max}$ l/min	135	178	230	287	
Power at $\Delta p = 280$ bar							
	at n_{nom} , $V_{g \max}$	P_{\max} kW	63	83	107	134	
Torque							
	at $V_{g \max}$ and	$\Delta p = 280$ bar	T_{\max} Nm	200	316	445	623
		$\Delta p = 100$ bar	T Nm	72	113	159	223
Rotary stiffness, drive shaft							
	S	c	Nm/rad	37500	71884	121142	169537
	R	c	Nm/rad	41025	76545	–	–
	P	c	Nm/rad	41232	80627	132335	188406
Moment of inertial rotary group		J_{TW} kgm ²	0.0033	0.0083	0.0167	0.0242	
Angular acceleration, maximum ²⁾		α rad/s ²	4000	3300	2700	2700	
Filling capacity		V L	1.0	1.6	2.2	3.0	
Weight (without through drive) approx.		m kg	21	33	45	60	

3) The values are applicable:

- ✚ for absolute pressure $P_{\text{abs}} = 1$ bar at the suction port S;
- ✚ for the optimum viscosity range of $V_{\text{opt}} = 16$ to 36 mm²/s
- ✚ for mineral-based operating materials

4) The scope of application lies between the minimum necessary and the maximum permissible drive speeds:

- ✚ Valid for external excitation;
- ✚ The limiting value is only valid for a single pump;
- ✚ The loading capacity of the connecting parts must be taken into account.
- ✚ If the drive speed continuous increasing and up to the limit speed, please conform to the curves shows.

□ Notes:

✚ Exceeding the maximum or falling below the minimum permissible values can lead to a loss of function, a reduction in operational service life or total destruction of the axial piston unit.

✚ We recommend checking the loading with tests or calculations / simulations and comparison with the permissible values.

□ Recommendation:

Sizes 45, 71, 100 and 140 are optionally available in high-speed version.

External dimensions are not affected by this option.

■ Technical data:

□ Permissible radial and axial loading on the drive shaft

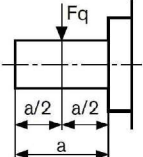
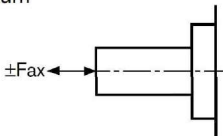
Size	NG		18	28	45	71	100	140
Radial force maximum at $a/2$		$F_{q,max}$ N	350	1200	1500	1900	2300	2800
Axial force maximum		$+F_{ax,max}$ N	700	1000	1500	2400	4000	4800

□ Permissible input and through-drive torques

Size	NG		18	28	45	71	100	140
Torque at $V_{g,max}$ and $\Delta p = 280 \text{ bar}^1$	T_{max}	Nm	80	125	200	316	445	623
Input torque for drive shaft, maximum ²⁾								
S	$T_{E,max}$	Nm	124	198	319	626	1104	1620
	\varnothing	in	3/4	7/8	1	1 1/4	1 1/2	1 3/4
R	$T_{E,max}$	Nm	160	250	400	644	–	–
	\varnothing	in	3/4	7/8	1	1 1/4	–	–
P	$T_{E,max}$	Nm	88	137	200	439	857	1206
	\varnothing	mm	18	22	25	32	40	45
Maximum through-drive torque for drive shaft								
S	$T_{D,max}$	Nm	108	160	319	492	778	1266
R	$T_{D,max}$	Nm	120	176	365	548	–	–
P	$T_{D,max}$	Nm	88	137	200	439	778	1206

□ Distribution of torques:

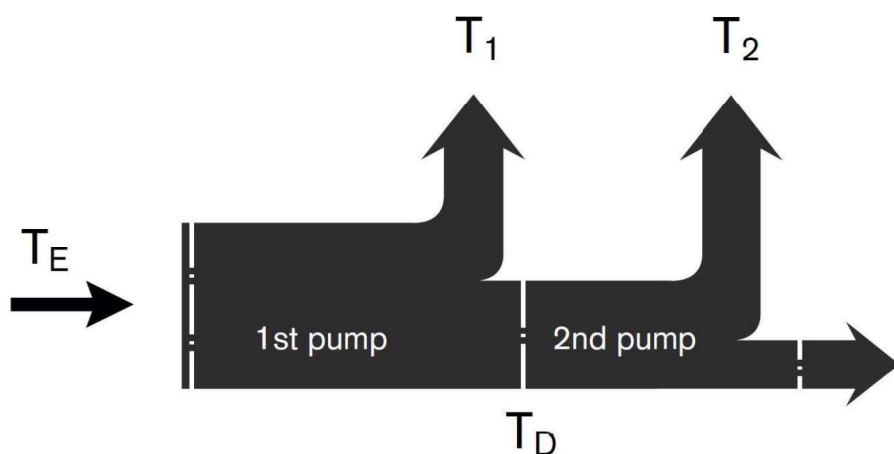

■ Drive power and flow:

□ Operating material:

Hydraulic fluid ISO VG 46 DIN 51519, $t = 50 \text{ }^\circ\text{C}$

□ Size10

--- n = 1500 rpm
 — n = 3600 rpm

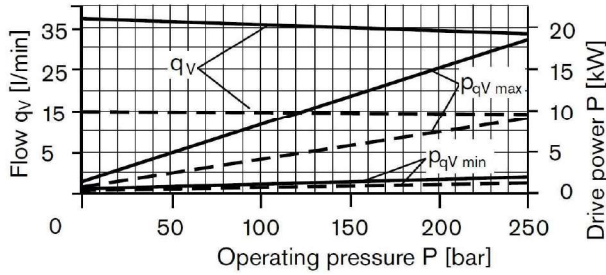

□ Size18

--- n = 1500 rpm
 — n = 3300 rpm

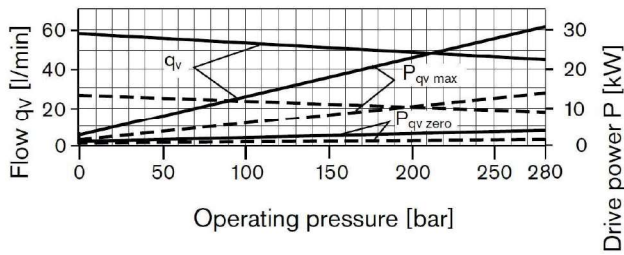

□ Size 28

--- n = 1500 rpm
 — n = 3000 rpm

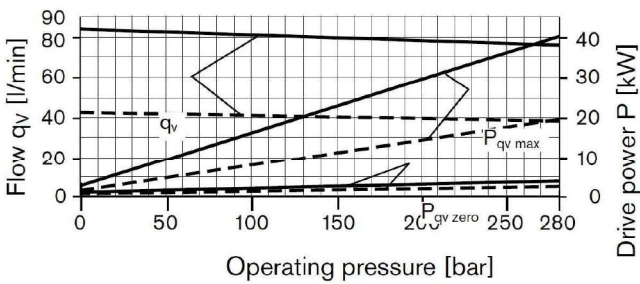

□ Size 45

--- n = 1500 rpm
 — n = 2600 rpm

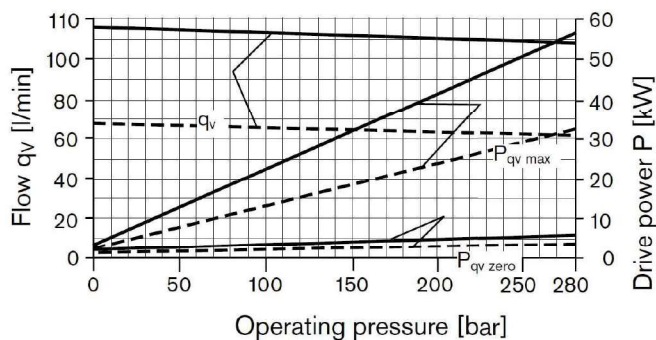

□ Size 71

--- n = 1500 rpm
 — n = 2200 rpm

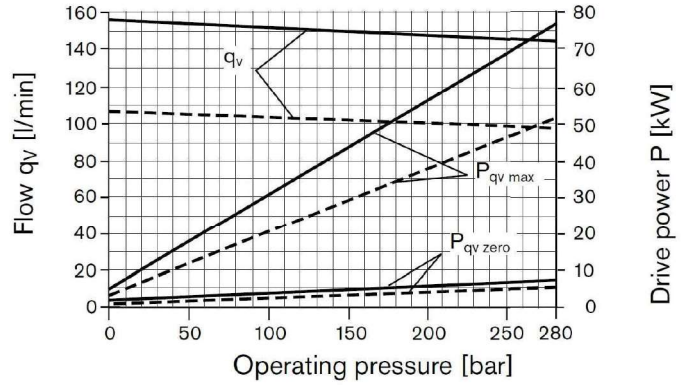

□ Size100

--- n = 1500 rpm
 — n = 2000 rpm

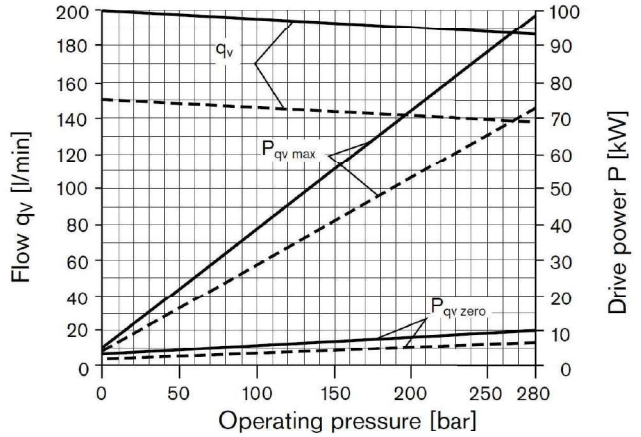

□ Size140

--- n = 1500 rpm
 — n = 1800 rpm

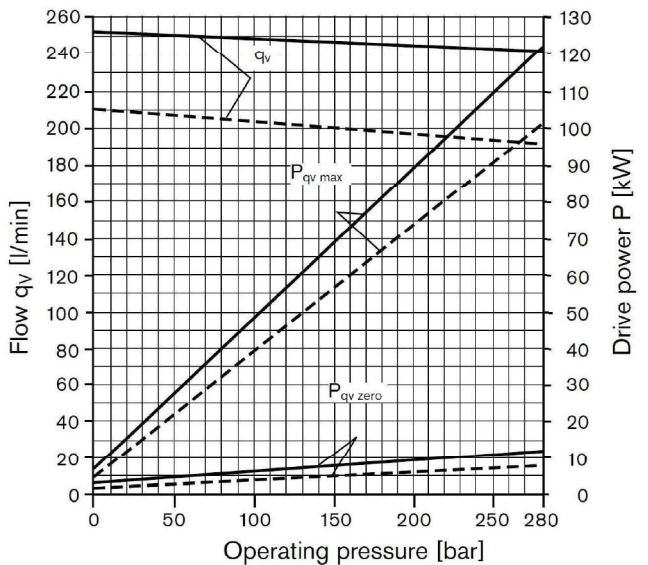

■ Characteristics curves.....Pressure control DR:

■ Noise level

Characteristics for pump

Measured in an anechoic chamber

Distance from microphone to pump = 3.3ft (1m)

Measuring error: ± 2dB(A)

Fluid: Hydraulic oil to DIN45 635, t=122°F (50°C)

□ Size 28

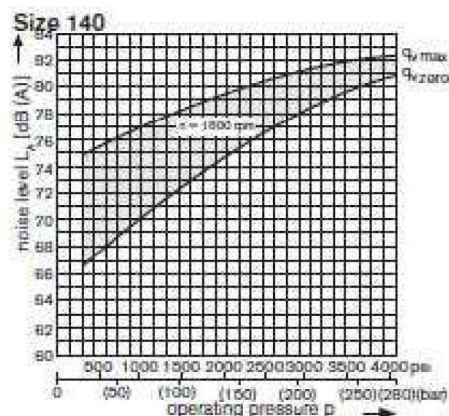
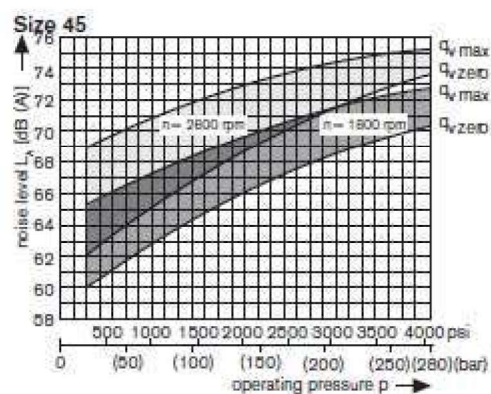
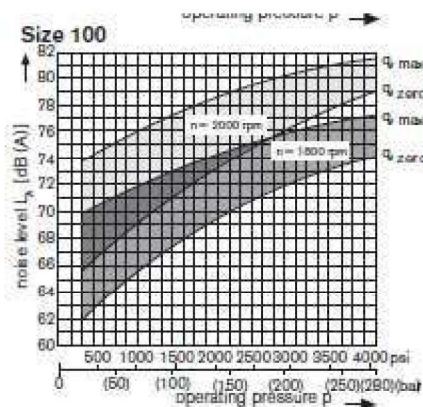
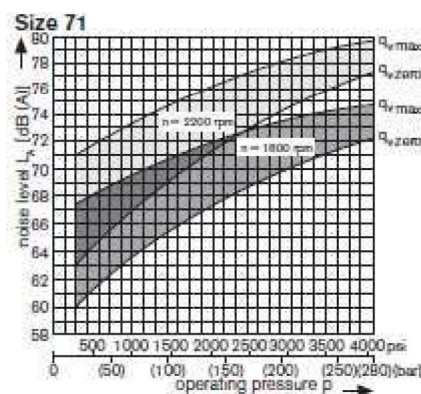
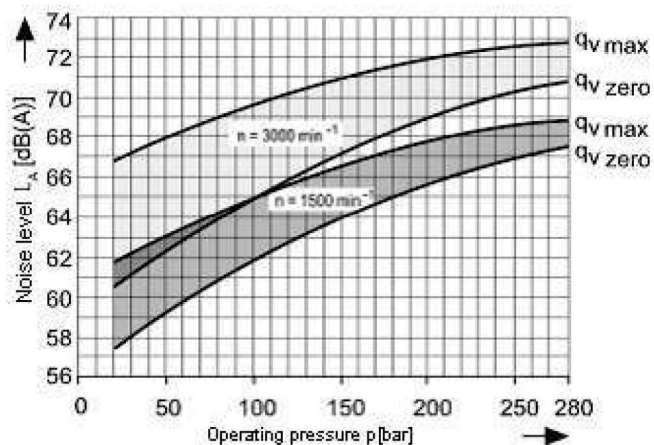

■ DG - Two-point control, directly operated

- Characteristics:
- The variable pump can be set to a minimum swivel angle by
- connecting an external control pressure to port X.
- This will supply control fluid directly to the stroke piston; a
- minimum control pressure of $p_{st} \geq 50$ bar is required
- The variable pump can only be switched between V_{gmax} or V_{gmin} .

■ Controls

- The required control pressure at port X is directly dependent on the actual operating pressure P_B in port B. (See control pressure characteristic).

Control pressure p_{st} in $X = 0$ bar $\hat{=}$ $V_{g max}$

Control pressure p_{st} in $X \geq 50$ bar $\hat{=}$ $V_{g min}$

□ Controller Data:

- Min operating pressure \square 50 bar
- Max operating pressure \square 120 bar

■ Control pressure characteristic:

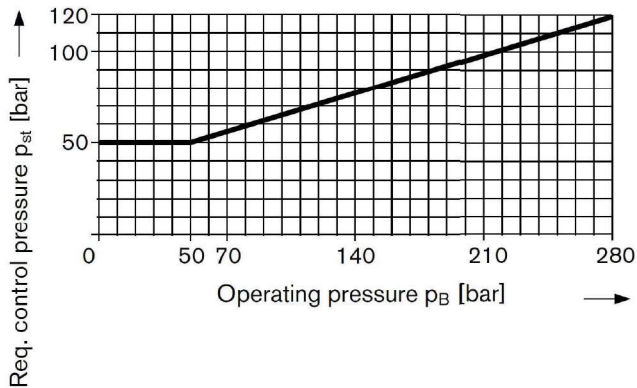

■ Circuit diagram:

- Size18...140 Series 31:

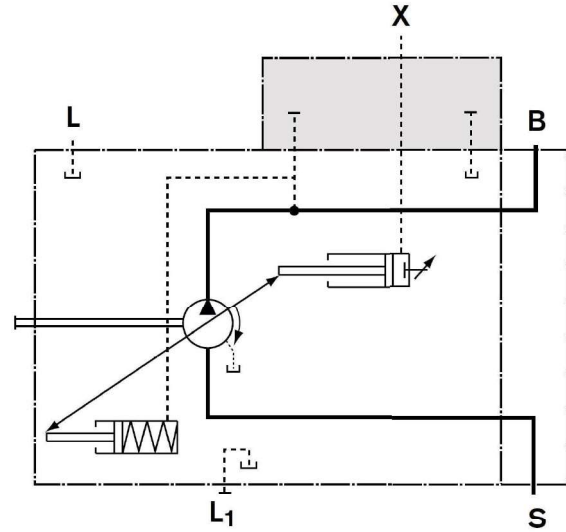

□ Service line port

	Port for
B	Service line
S	Suction line
L, L ₁	Case drain (L ₁ plugged)
X	Pilot pressure

■ DR – Pressure control:

■ Characteristics:

The pressure control limits the maximum pressure at the pump output within the pump control range. The variable pump only supplies as much hydraulic fluid as is required by the consumers.

If the operating pressure exceeds the pressure setpoint set at the integrated pressure valve, the pump will adjust towards a smaller displacement and the control deviation will be reduced. The pressure can be set steplessly at the control valve.

Pressure setting range:

Size10	Series 52	25...250 bar
Size18...100	Series 31	25...280 bar

■ Static characteristic:

□ Working Conditions: $n = 1500 \text{ rpm}$ $t_{oil} = 50^\circ\text{C}$

□ Size10 Series 52

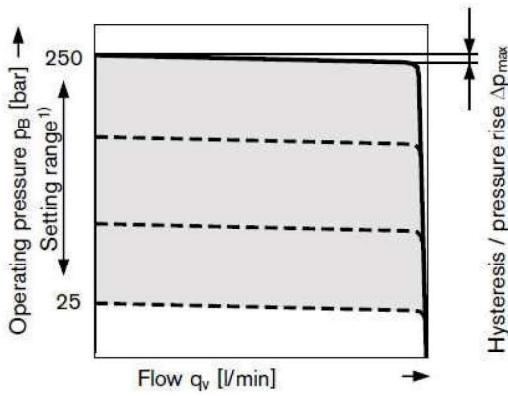

□ Size18...100 Series 31

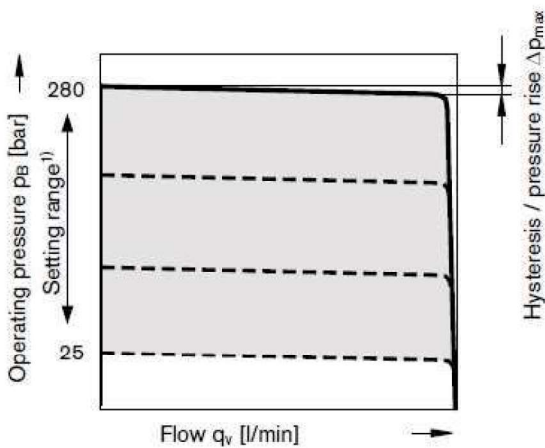

1) In order to prevent damage to the pump and the system, this setting range is the permissible setting range and must not be exceeded. The range of possible settings at the valve is higher.

■ Controller Data:

□ Hysteresis and repeatability Δpmaximum 3 bar

□ Pressure rise, maximum:

Size	10	18	28	45	71	100	140
Δp bar	6	4	4	6	8	10	12

□ Control fluid consumption.....maximum approx.3 L/min

■ Circuit diagram:

□ Size10 Series 52

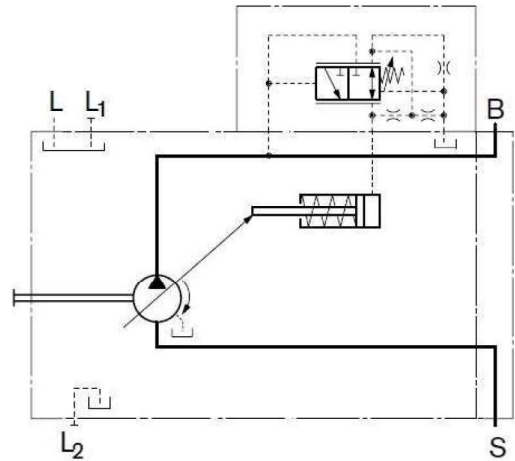

□ Size18...100 Series31

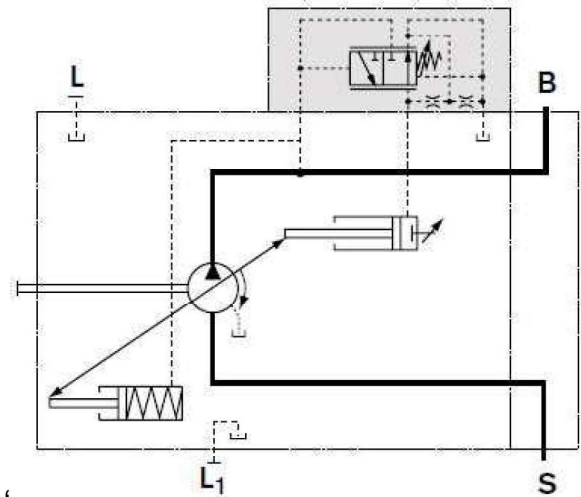

□ Size 140 Series31

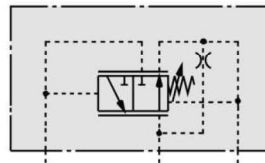

□ Service line port

Port	Port for
B	Service line
S	Suction line
L, L ₁	Case drain (L ₁ plugged)

- DRG - Pressure control, remotely operated
- Characteristics:
 - The pressure control limits the maximum pressure at the pump output within the pump control range. The variable pump only supplies as much hydraulic fluid as is required by the consumers. The pressure can be set steplessly at the control valve.
 - The DRG control valve overrides the function of the DR pressure controller
 - A pressure relief valve can be externally piped to port X for remote setting of pressure below the setting of the DR control valve spool. This relief valve is not included in the delivery contents of the DRG control. As per consumers' requirements, the DRG controller can also be equipped with pressure regulating valve block or multiple pressure regulating valve block specially designed for HUADE hydraulic.
 - The max. length of piping should not exceed 2 m.
- Setting:
 - The differential pressure at the DRG control valve is set as standard to 20 bar. This results in a pilot oil flow to the relief valve of approx. 1.5 l/min at port X. If another setting is required (range from 10-22 bar) please state in clear text.
- Static characteristic:
 - Working Conditions: $n = 1500 \text{ rpm}$ $t_{oil} = 50^\circ\text{C}$
 - Size10 Series 52

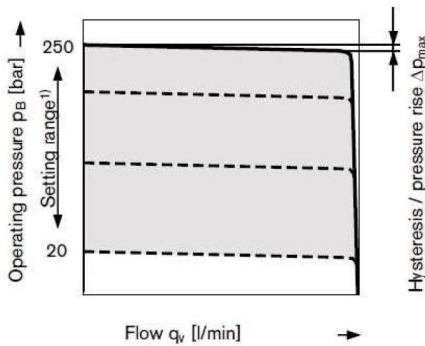

□ Size18...140 Series 31

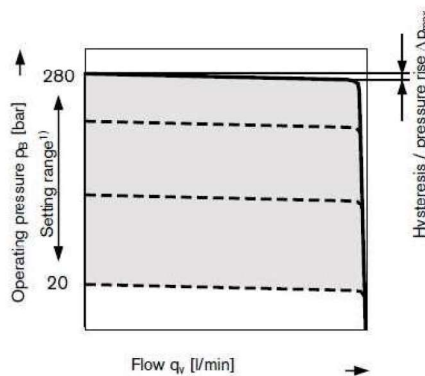

1) In order to prevent damage to the pump and the system, this setting range is the permissible setting range and must not be exceeded. The range of possible settings at the valve is higher

- Controller data:
 - Hysteresis and repeatability Δpmaximum 3 bar
 - Pressure rise, maximum:

Size	10	18	28	45	71	100	140
Δp bar	6	4	4	6	8	10	12

- Control fluid consumption.....maximum approx.4.5 L/min

- Circuit diagram:
- Size10 Series 52

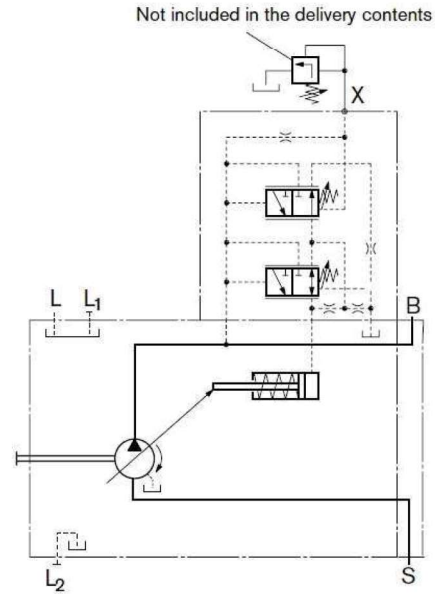

- Size18...100 Series31

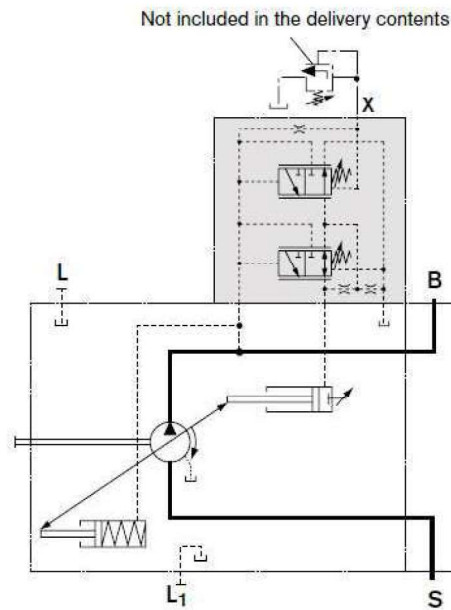

- Size140

Not included in the delivery contents

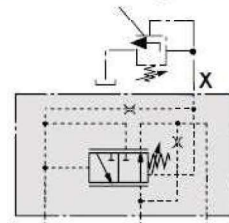

- Connection lines:

- B Service line
- S Suction line
- L/L1 Case drain (L1 plugged)
- X Pilot pressure Size10...100 with adapter
- X Pilot pressure Size140 without adapter

■ DFR/DFR1– Pressure and flow control

□ Constant flow control

■ Characteristics:

□ In addition to the pressure control function, the pump flow may be varied by means of a differential pressure over an adjustable orifice installed in the service line to the actuator. The pump flow is equal to the actual required flow by the actuator, regardless of changing pressure levels.

□ The pressure control overrides the flow control function

■ Setting:

□ The DFR1 version has no connection between X and the reservoir. Unloading the LS-pilot line must be possible in the valve system.

□ Because of the flushing function sufficient unloading of the X-line must also be provided.

■ Static characteristic:

(n = 1500 rpm t_{oil} = 50°C)

□ Size10 Series 52

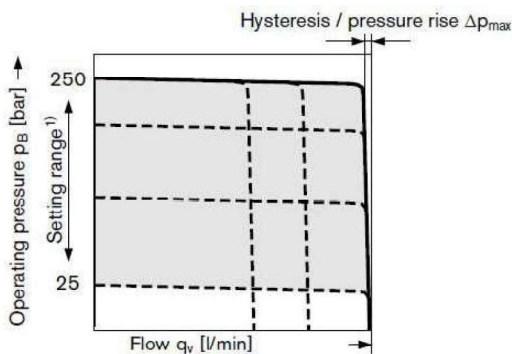

□ Size18...140 Series 31

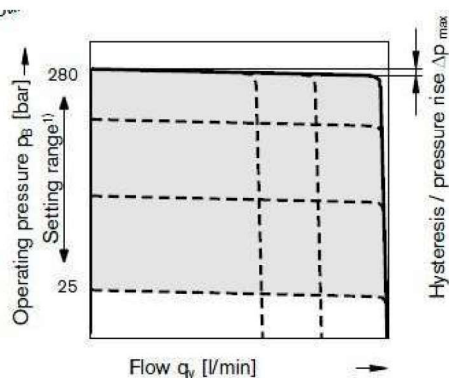

1) In order to prevent damage to the pump and the system, this setting range is the permissible setting range and must not be exceeded.

■ Static characteristic at variable speed:

□ Size10 Series 52

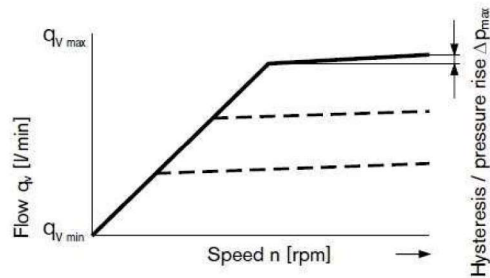

□ Size18...140 Series31

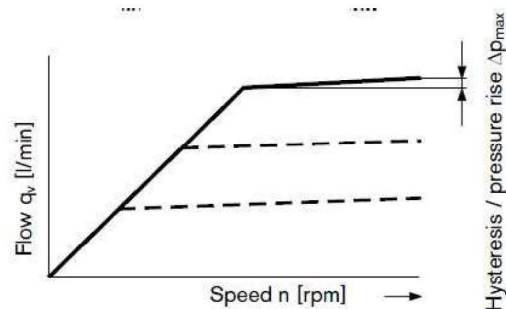

□ Differential pressure Δp

Standard setting: 14 to 22 bar.

If another setting is required, please state in clear text.

□ Relieving the load on port X to the reservoir results in a zero stroke ("standby") pressure which lies about 1 to 2 bar higher than the differential pressure Δp. System influences are not taken into account.

■ Controller data :

□ Hysteresis and repeatability Δp.....maximum 3 bar

□ Pressure rise, maximum:

Size	10	18	28	45	71	100	140
Δp bar	6	4	4	6	8	10	12

□ Control fluid consumption..... maximum approx.4.5 L/min

■ Maximum flow deviation:

□ Measured at drive speed n = 1500 rpm

Size	10	18	28	45	71	100	140
Δq _{max} l/min	0.5	1.0	1.0	1.8	2.8	4.0	6.0

□ Control fluid consumption DFR_maximum approx. 3 to 4.5 l/min

□ Control fluid consumption DFR1_____ maximum approx. 3 l/min

■ DFR/DFR1– Pressure and flow control:

■ Circuit diagram:

□ Size 10 Series 52

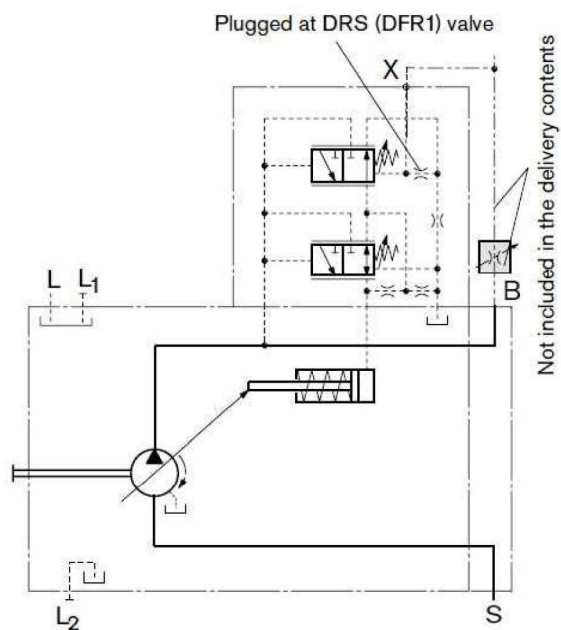

■ Circuit diagram:

□ Size 18...100 Series 31

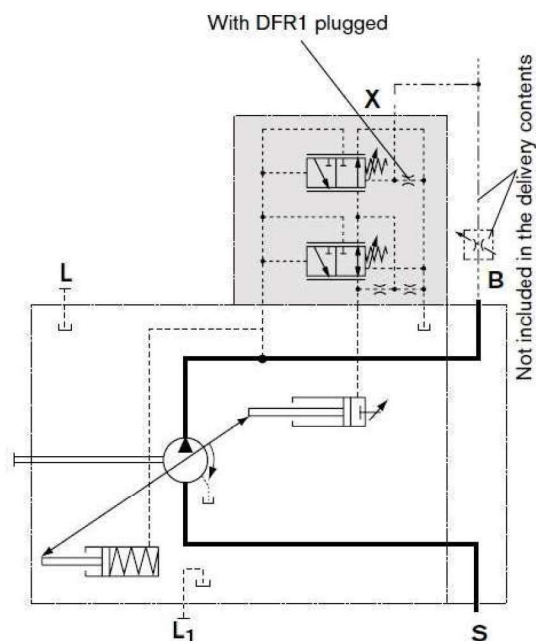

□ Size 140 Series 31

□ Connection lines:

- B Service line
- S Suction line
- L/L₁ Case drain (L₁ plugged)
- X Pilot pressure

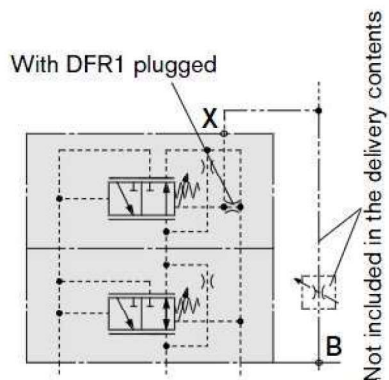

■ DFLR – Pressure, flow and power control:

- Constant power control

■ Characteristics:

- In order to achieve a constant drive torque with varying operating pressures, the swivel angle and with it the output flow from the axial piston pump is varied so that the product of flow and pressure remains constant.
- Flow control is possible below the power control curve.

■ Static curves and torque characteristic:

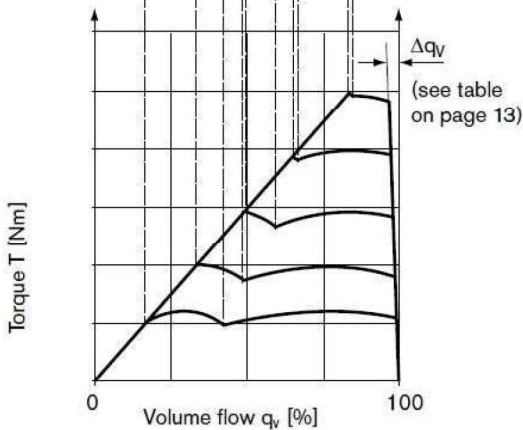
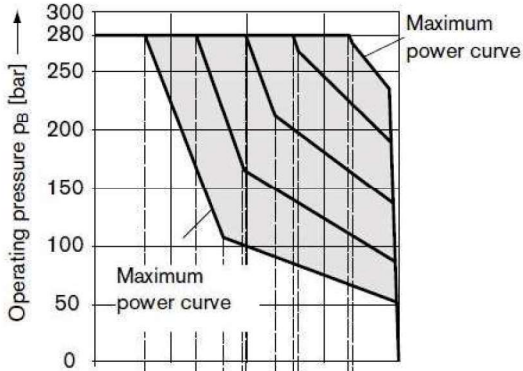

- The power characteristic is set in the factory; when ordering, please state in clear text, e.g. 20 kW at 1500 rpm.

■ Controller data:

- Beginning of control.....50 bar
- Control fluid consumption.....maximum approx. 5.5 L/min
- For pressure control DR data: See page 14.
- For flow control FR data: See page 16.

□ Connection lines:

- B Service line
- S Suction line
- L/L₁ Case drain (L₁ plugged)
- X Pilot pressure

■ Circuit diagram:

- Size10 Series 52

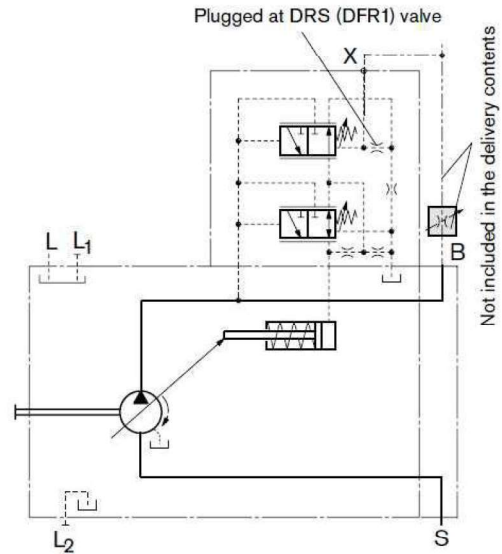

- Size18...100 Series31

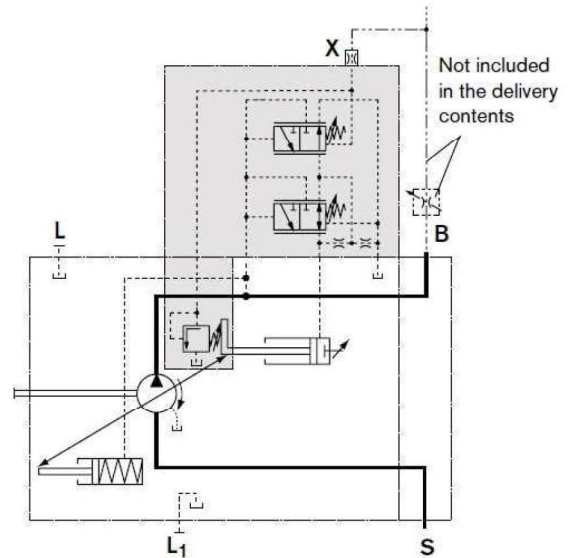

- Size 140 Series 31

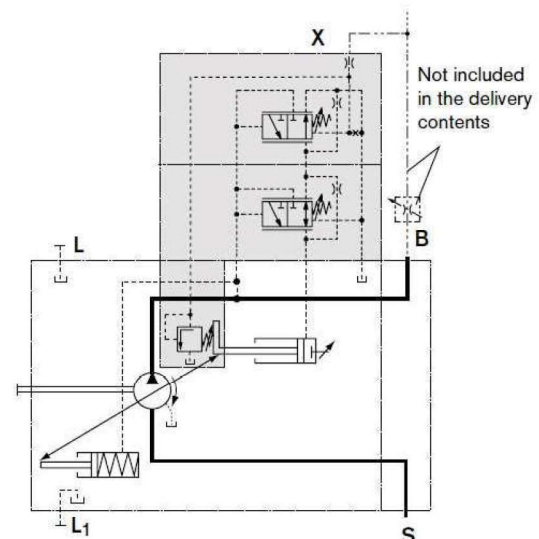

- ED – Electro-hydraulic pressure control:
- Electro-hydraulic pressure control...negative characteristic

■ Characteristics:

- The ED valve is set to a certain pressure by a specified, variable solenoid current, If there is a change at the consumer (load pressure), the position of the control piston changes.
- This causes an increase or decrease in the pump swivel angle (flow) in order to maintain the electrically set pressure level. The pump thus only delivers as much hydraulic fluid as the consumers can take. The desired pressure level can be set steplessly by varying the solenoid current.
- When the solenoid current signal drops towards a zero value, the maximum output pressure is limited to p_{max} by an adjustable hydraulic pressure cut-off.
- The response time characteristic of the ED-control was optimized for the use as a fan drive system. When ordering, state the type of application in clear text.

■ Static current-pressure characteristic ED:

- Measured at pump in zero stroke - negative characteristic
- Hysteresis of the static current-pressure characteristic < 3 bar

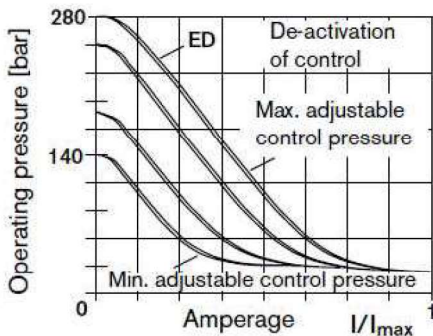

■ Static flow-pressure characteristic:

- At $n = 1500 \text{ rpm}$ $t_{oil} = 50^\circ\text{C}$

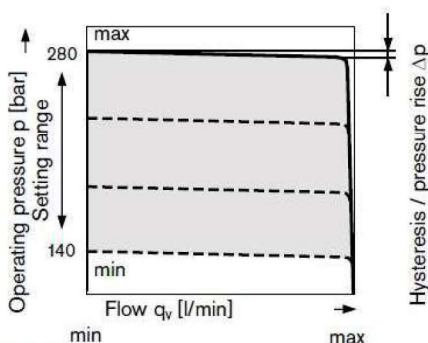

Control data

Stand-by standard setting 20 bar, other values on request.

Hysteresis and pressure increase _____ $\Delta p < 4 \text{ bar}$
 Control fluid consumption _____ 3 to 4.5 l/min.

■ Influence of pressure setting on standby level:

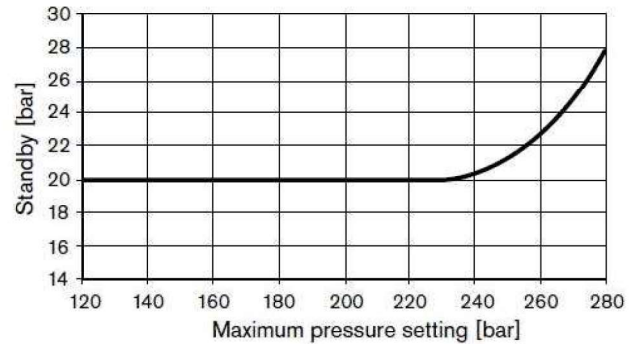

■ Circuit diagram:

- Size 18... 100 Series 31

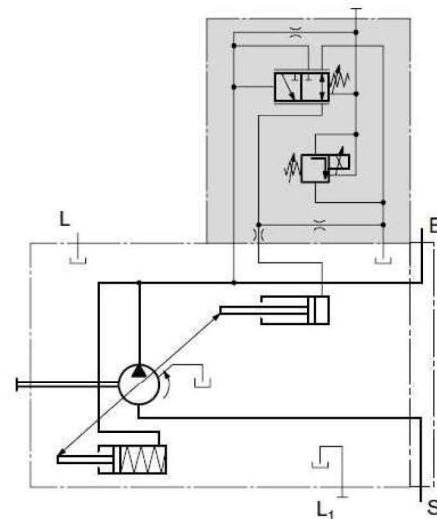

□ Connection lines:

- B Service line
- S Suction line
- L/L₁ Case drain (L₁ plugged)

■ Technical data:

- Operating temperature range at valve -20°C to $+115^\circ\text{C}$

Technical data, solenoid	ED71	ED72
Voltage	12 V ($\pm 20\%$)	24 V ($\pm 20\%$)
Control current		
Control begin at $q_{v \text{ min}}$	100 mA	50 mA
End of control at $q_{v \text{ max}}$	1200 mA	600 mA
Limiting current	1.54 A	0.77 A
Nominal resistance (at 20°C)	5.5Ω	22.7Ω
Dither frequency	100 to 200 Hz	100 to 200 Hz
Actuated time	100 %	100 %
For type of protection, see plug design on page 43		
For details on the control electronics, see page 16		

- ER – Electro-hydraulic pressure control:
- Electro-hydraulic pressure control...positive characteristic

■ Characteristics:

- The ER valve is set to a specific pressure by a specified, variable solenoid current. If there is a change at the consumer (load pressure), the position of the control piston changes.
- This causes an increase or decrease in the pump swivel angle (flow) in order to maintain the electrically set pressure level. The pump thus only delivers as much hydraulic fluid as the consumers can take. The desired pressure level can be set steplessly by varying the solenoid current.
- If the solenoid current drops to zero, the pressure is limited to p_{min} (stand-by).

■ Static current-pressure characteristic ER:

- measured at pump in zero stroke - positive characteristic
- Hysteresis of the static current-pressure characteristic < 3 bar
- Influence of pressure setting on stand-by ± 2 bar

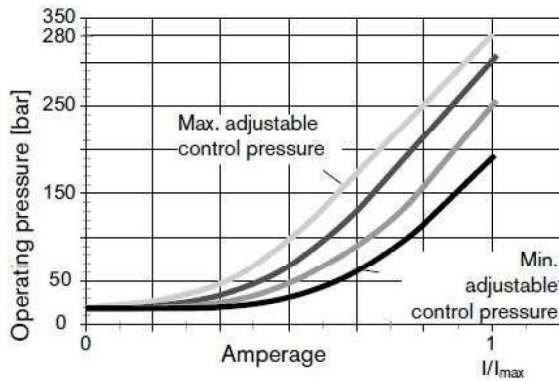

■ Static flow-pressure characteristic:

- At $n = 1500$ rpm $t_{oil} = 50^\circ\text{C}$

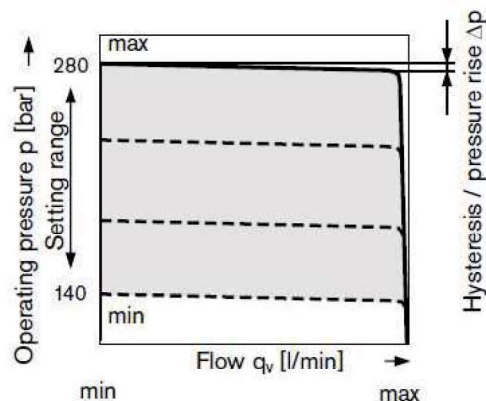

■ Control data:

- Standby standard setting 20 bar, other values on request.
- Hysteresis and pressure increase..... $\Delta p < 4$ bar
- Control fluid consumption..... 3~4.5 L/min

- Circuit diagram:
- Size 18...100 Series 31

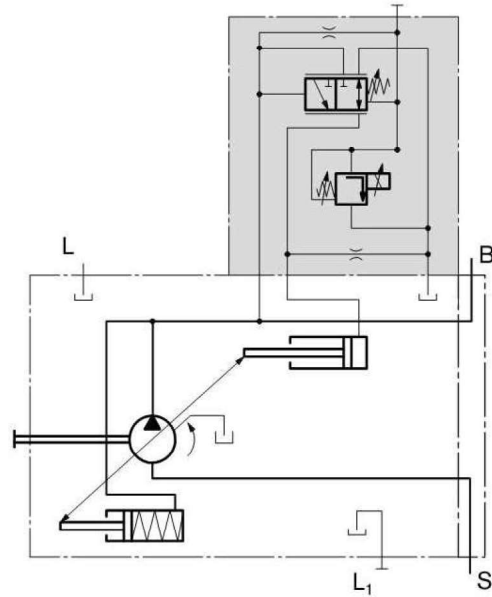

□ Connection lines:

- B Service line
- S Suction line
- L/L₁ Case drain (L₁ plugged)

■ Technical data:

- operating temperature range at valve -20°C to $+115^\circ\text{C}$

Technical data, solenoid	ED71	ED72
Voltage	12 V ($\pm 20\%$)	24 V ($\pm 20\%$)
Control current		
Control begin at $q_v \min$	100 mA	50 mA
End of control at $q_v \max$	1200 mA	600 mA
Limiting current	1.54 A	0.77 A
Nominal resistance (at 20°C)	5.5 Ω	22.7 Ω
Dither frequency	100 to 200 Hz	100 to 200 Hz
Actuated time	100 %	100 %
For type of protection, see plug design on page 43		

■ Dimensions: Size10 Series 52

□ DR - Pressure control:

□ Centering flange SAE version

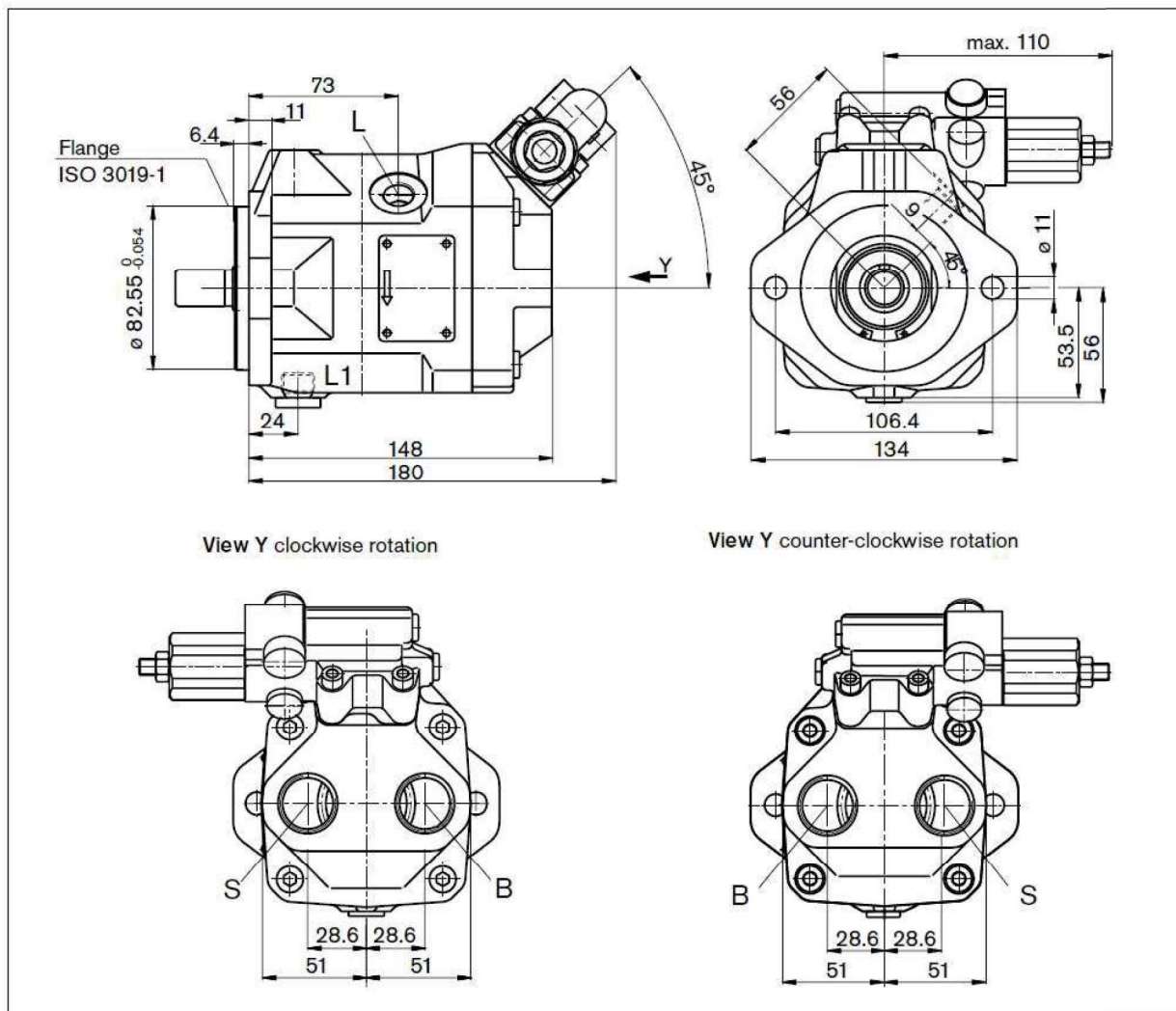

DRG

Pressure and flow control, remote controlled

DFR / DFR1

Pressure and flow control

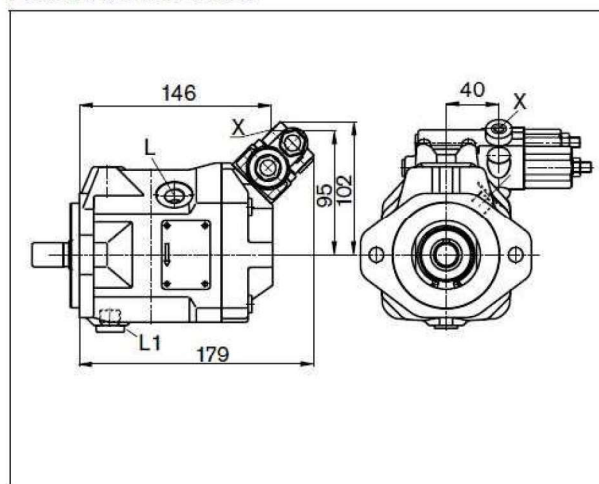
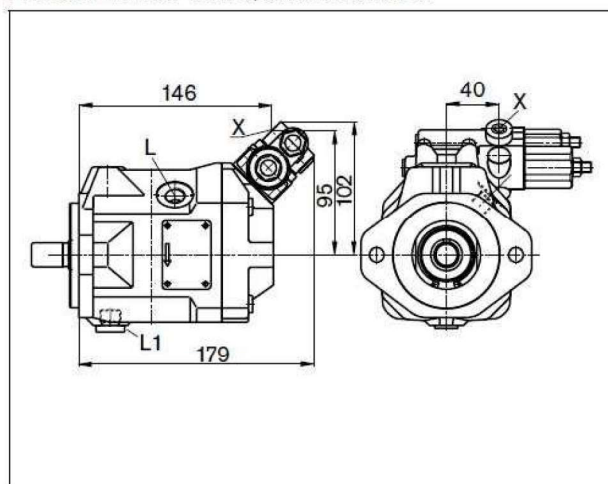

■ Dimensions : Size10 Series 52

- DR - Pressure control:
- Center flange metric version

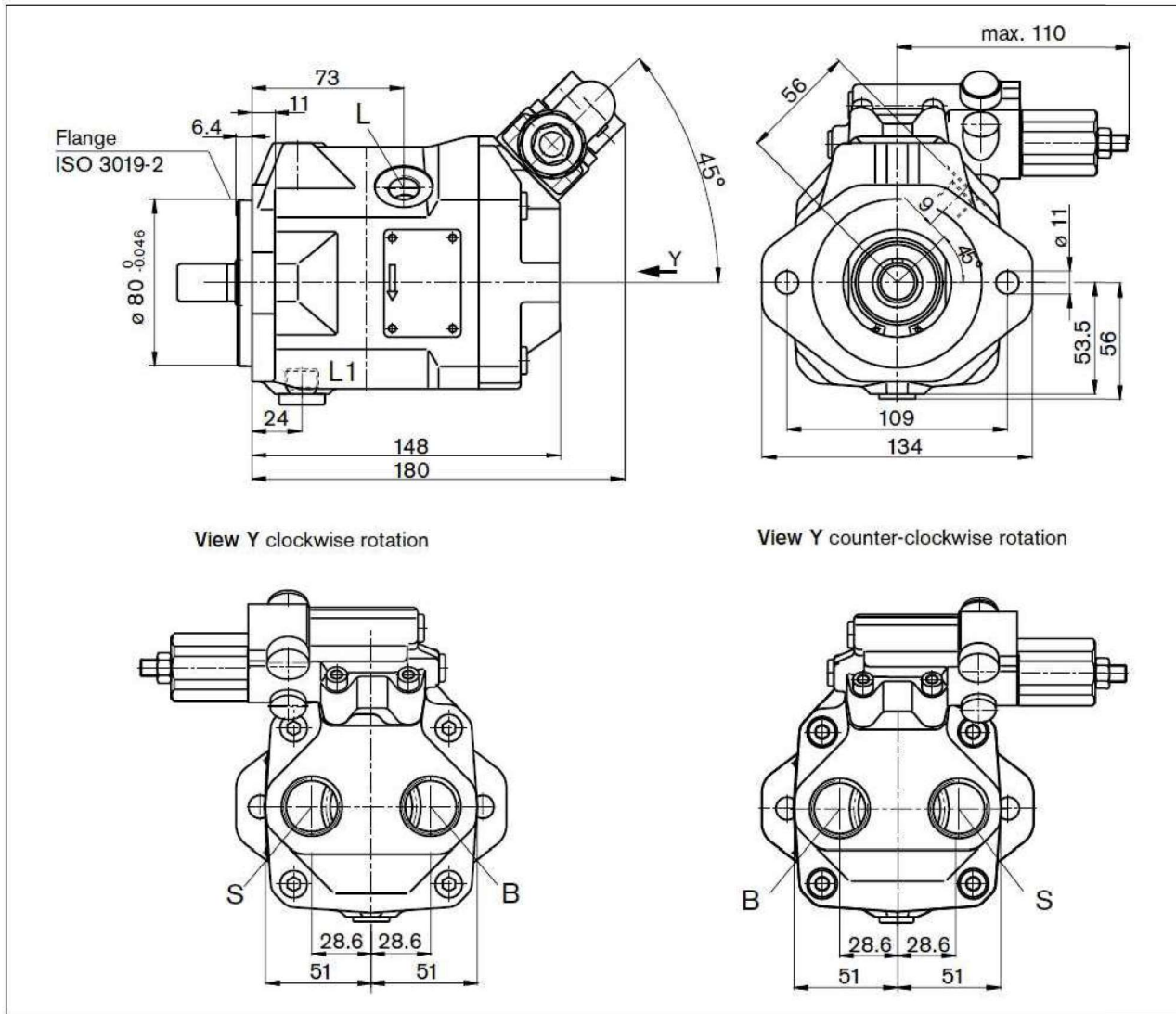

DRG

Pressure control, remotely operated

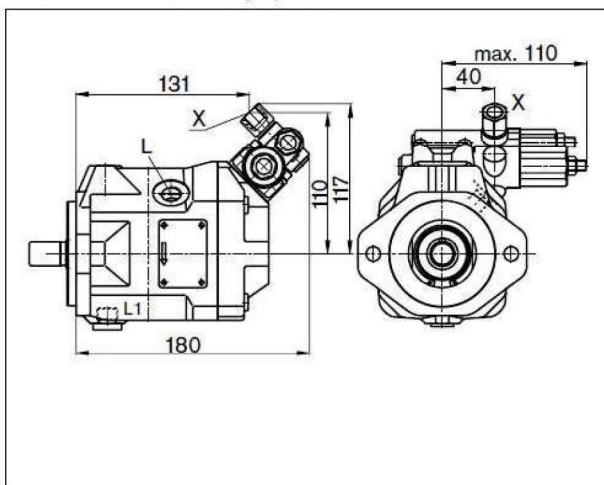

DFR / DFR1

Pressure and flow control

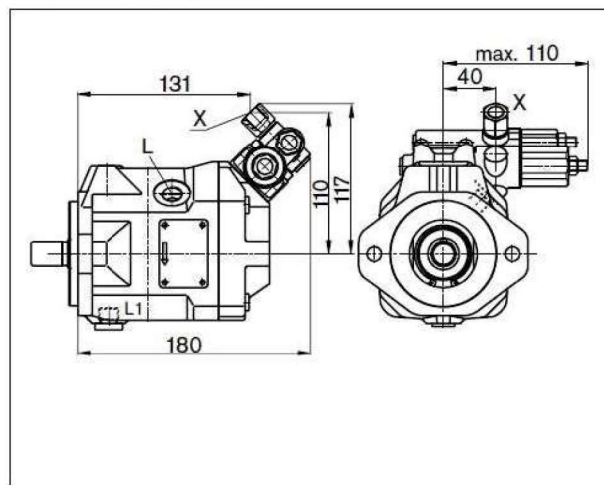

■ Dimensions: Size10 Series 52

□ Drive shaft:

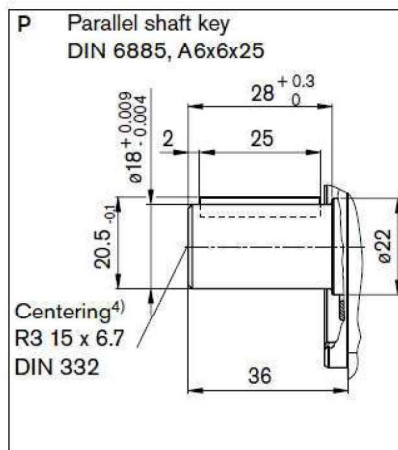
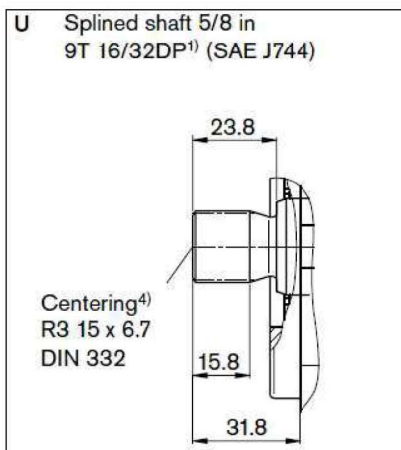
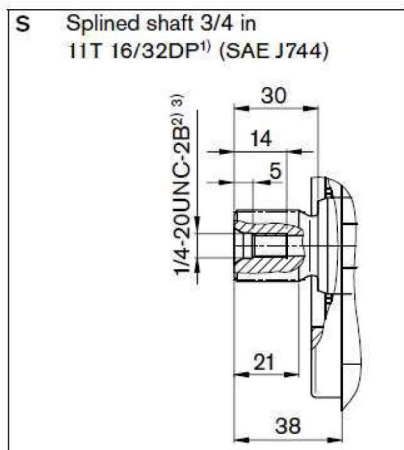

1) ANSI B92.1a, 30° pressure angle, flat root, side fit, tolerance class 5

2) Thread according to ASME B1.1

3) For the maximum tightening torques the general instructions on page 9 must be observed.

4) Coupling axially secured, e.g. with a clamp coupling or radially mounted clamping screw

□ Ports:

Designation	Port for	Standard	Size	Maximum pressure (bar)	State
B	Service line	DIN 3852	M27 X 2 16 deep	315	O
S	Suction line	DIN 3852	M27 X 2 16 deep	5	O
L...metric	Case drain fluid	DIN 3852	M16 X 1.5 12 deep	2	O
L1...metric	Case drain fluid	DIN 3852	M16 X 1.5 12 deep	2	X
L...SAE	Case drain fluid	ISO 11926	9/16-18 UNF-2B 16 deep	2	O
L1...SAE	Case drain fluid	ISO 11926	9/16-18 UNF-2B 16 deep	2	X
X...with adapter	Pilot pressure	DIN 3852	M14 X 1.5 11.5 deep	315	O
X...without adapter	Pilot pressure	ISO 11926	7/16-20 UNF-2B 11.5 deep	315	O

□ O = Must be connected (plugged on delivery)

□ X = Plugged (in normal operation)

■ Dimensions: Size 18

□ DFR/DFR1 - Pressure and flow control, hydraulic:

□ Clockwise rotation

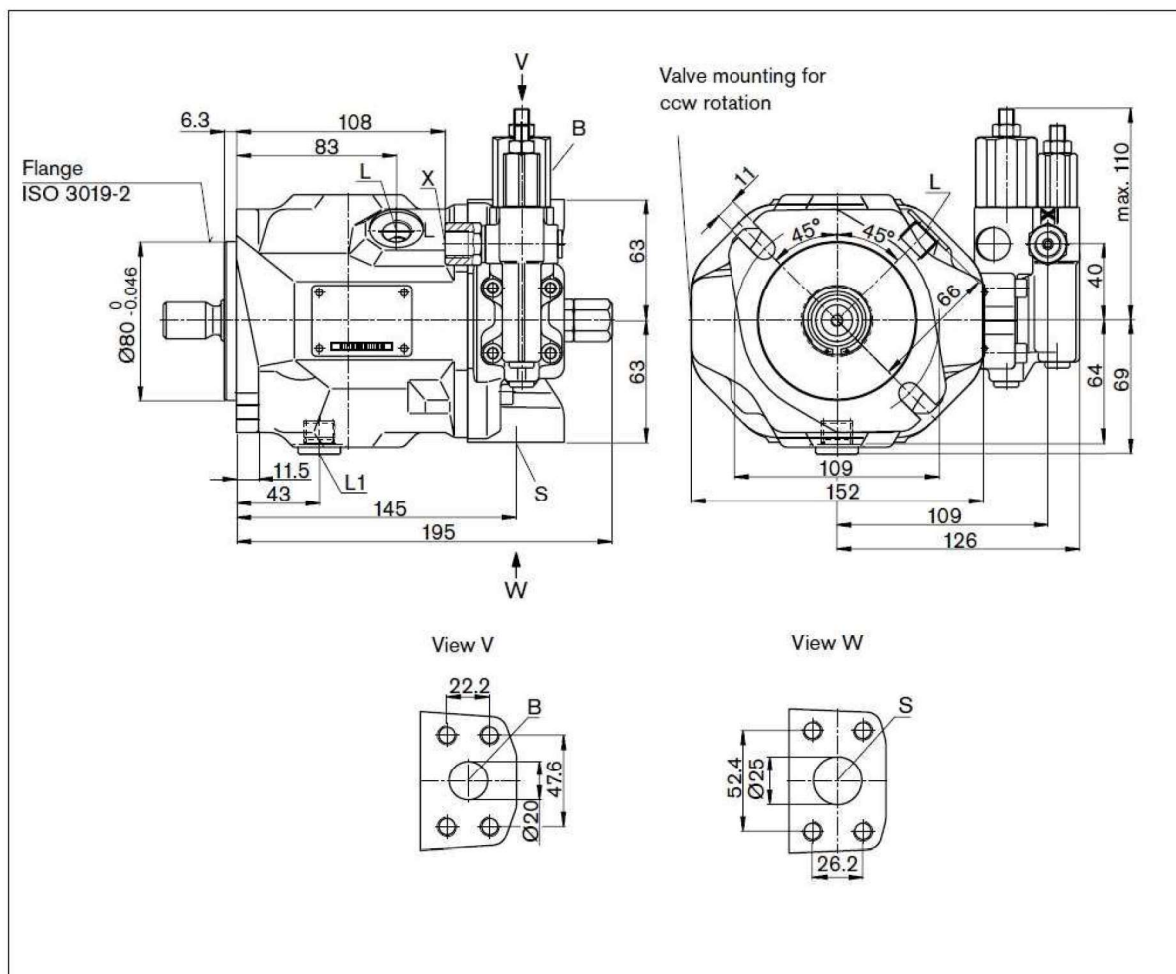

□ Ports:

Designation	Port for	Standard	Size	Maximum pressure (bar)	State
B	Service line fastening thread	SAE J518 DIN 13	3/4" M10 X 1.5 17 deep	350	O
S	Suction line fastening thread	SAE J518 DIN 13	1" M10 X 1.5 17 deep	10	O
L	Case drain fluid	DIN 3852	M16 X 1.5 12 deep	2	O
L ₁	Case drain fluid	DIN 3852	M16 X 1.5 12 deep	2	X
X	Pilot pressure	DIN 3852	M14 X 1.5 12 deep	350	O
X	Pilot pressure with DG-control	ISO 228	G 1/4" 12 deep	350	O

□ O = Must be connected (plugged on delivery)

□ X = Plugged (in normal operation)

■ Dimensions: Size 18

□ Drive shaft:

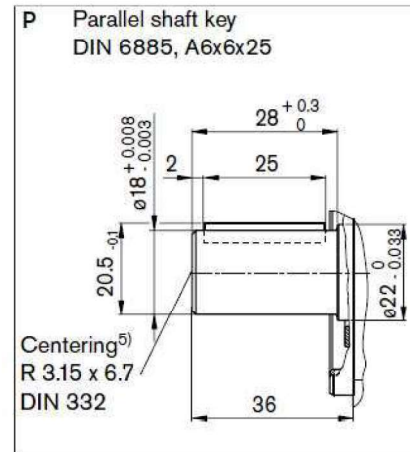
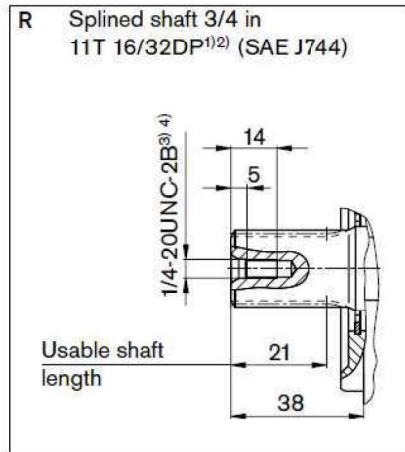
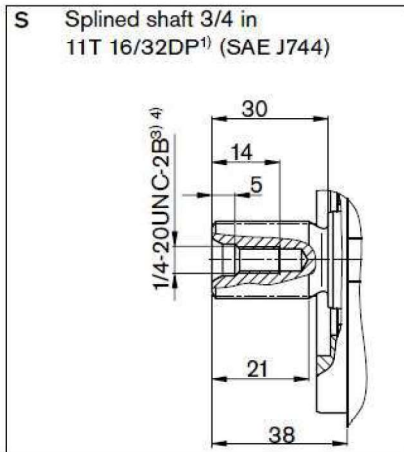

1) ANSI B92.1a, 30° pressure angle, flat root, side fit, tolerance class 5

2) Splines according to ANSI B92.1a, run out of spline is a deviation from standard

3) Thread according to ASME B1.1

4) For the maximum tightening torques the general instructions on [page 9](#) must be observed

5) Coupling axially secured, e.g. with a clamp coupling or radially mounted clamping screw

■ Dimensions: Size18

DG

Two-point control, directly operated

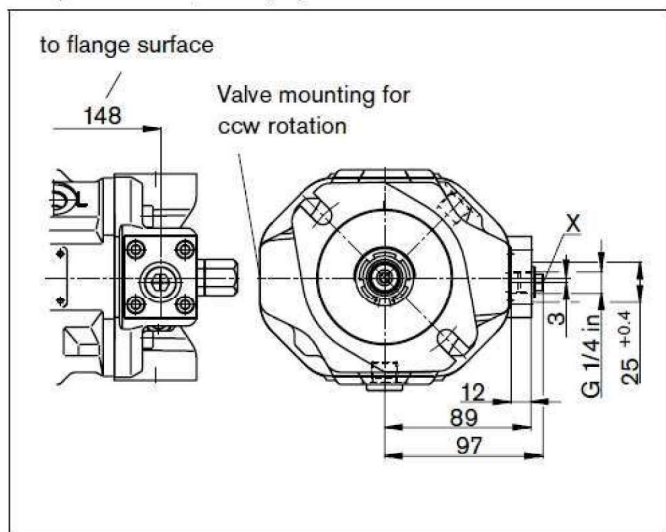

DR

Pressure control

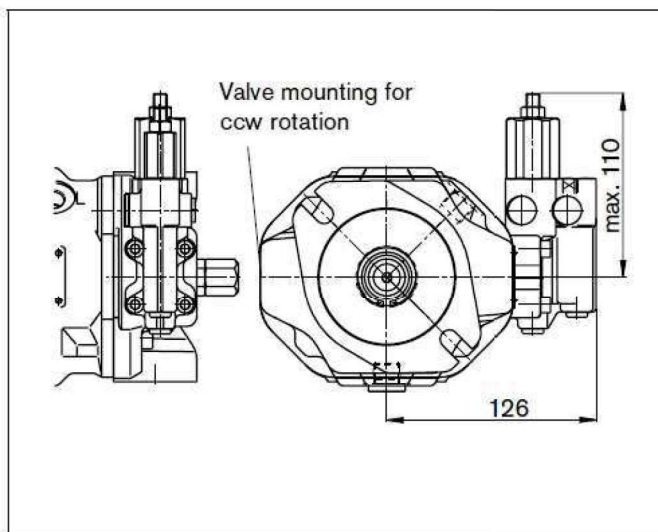

DRG

Pressure control, remotely operated

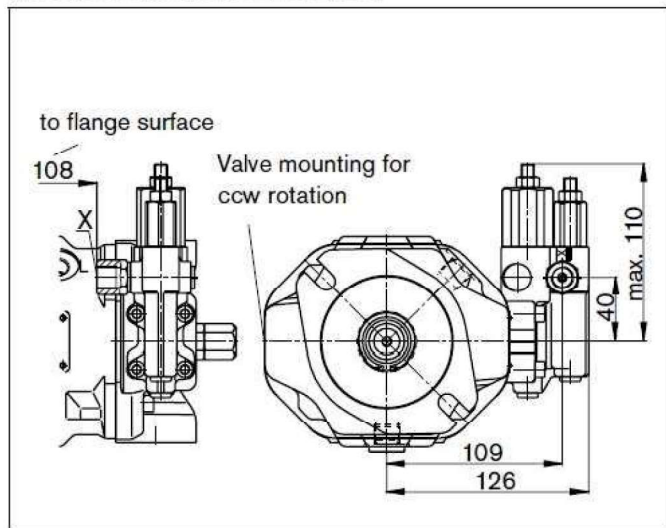

ED7., ER7.

Electro-hydraulic pressure control

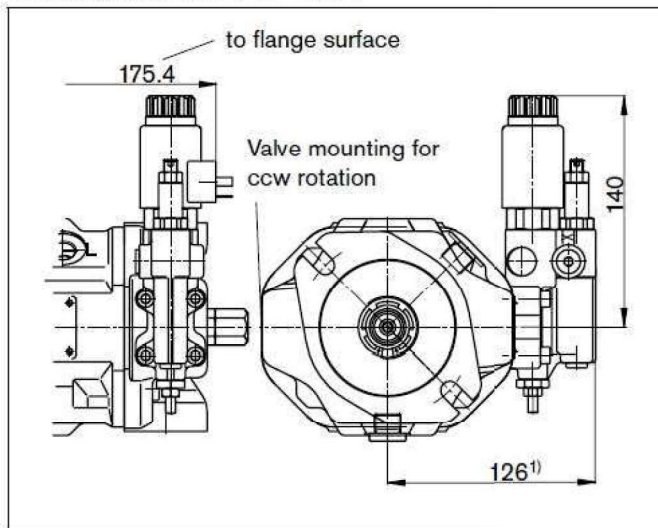

1) ER7.: 161 mm if using a sandwich plate pressure reducing valve.

■ Dimensions: Size 28

□ DFR/DFR1 – Pressure and flow control, hydraulic:

□ Clockwise rotation

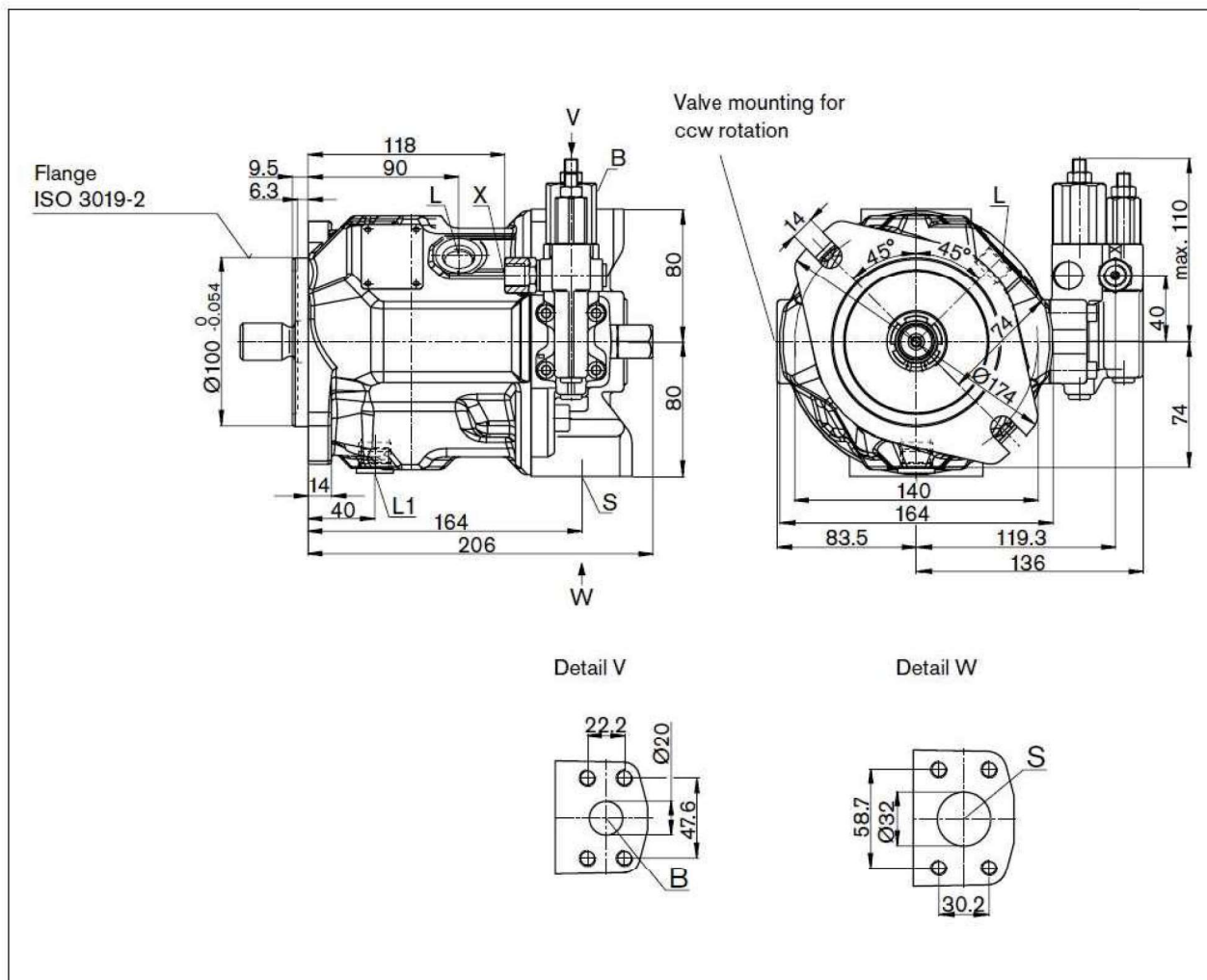

□ Ports:

Designation	Port for	Standard	Size	Maximum pressure (bar)	State
B	Service line fastening thread	SAE J518 DIN 13	3/4" M10 X 1.5 17 deep	350	O
S	Suction line fastening thread	SAE J518 DIN 13	1-1/4" M10 X 1.5 17 deep	10	O
L	Case drain fluid	DIN 3852	M18 X 1.5 12 deep	2	O
L ₁	Case drain fluid	DIN 3852	M18 X 1.5 12 deep	2	X
X	Pilot pressure	DIN 3852	M14 X 1.5 12 deep	350	O
X	Pilot pressure with DG-control	ISO 228	G 1/4" 12 deep	350	O

□ O = Must be connected (plugged on delivery)

□ X = Plugged (in normal operation)

■ Dimensions: Size 28

□ Drive shaft:

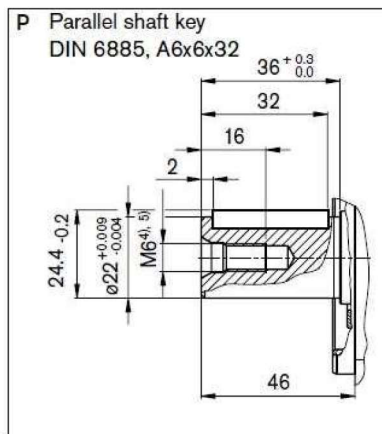
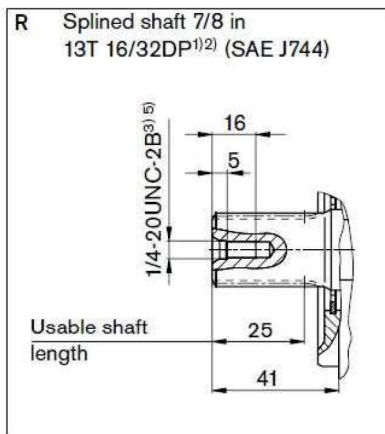
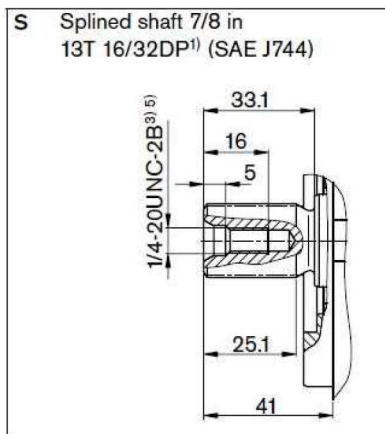

- 1) ANSI B92.1a, 30° pressure angle, flat root, side fit, tolerance class 5
- 2) Spline according to ANSI B92.1a, run out of spline is a deviation from standard.
- 3) Thread according to ASME B1.1
- 4) Thread according to DIN 13
- 5) For the maximum tightening torques the general instructions **on page 9 must be observed.**

■ Dimensions: Size 28

DG

Two-point control, directly operated

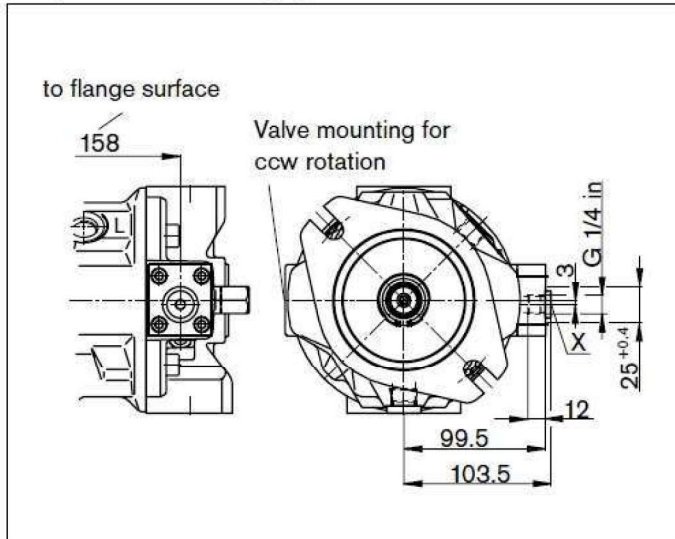

DFLR

Pressure, flow and power control

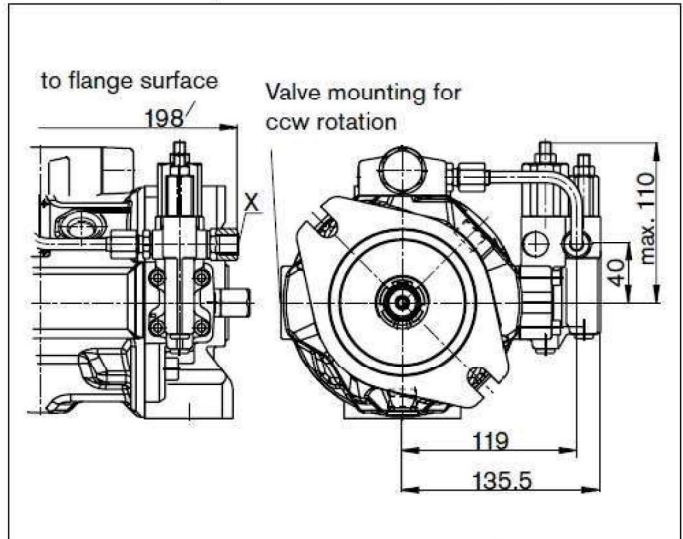

DR

Pressure control

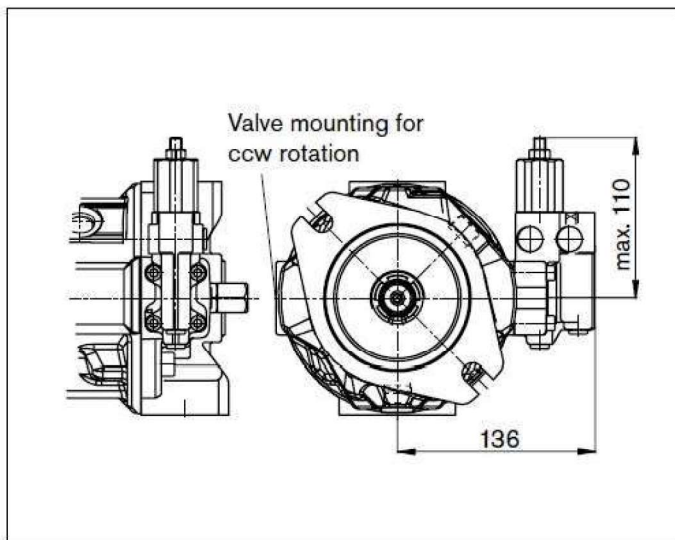

DRG

Pressure control, remotely operated

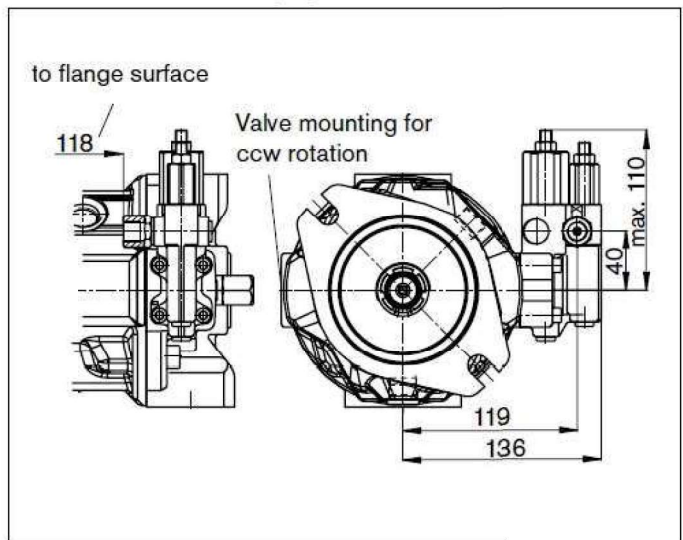

ED7. / ER7.

Electro-hydraulic pressure control

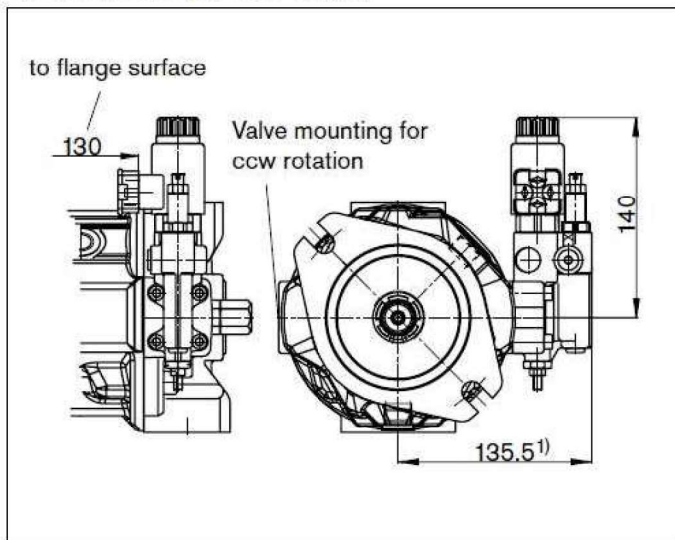

1) ER7.: 170.5 mm when using a sandwich plate pressure reducing valve.

■ Dimensions: Size 45

□ Pressure and flow control, hydraulic:

□ Clockwise rotation

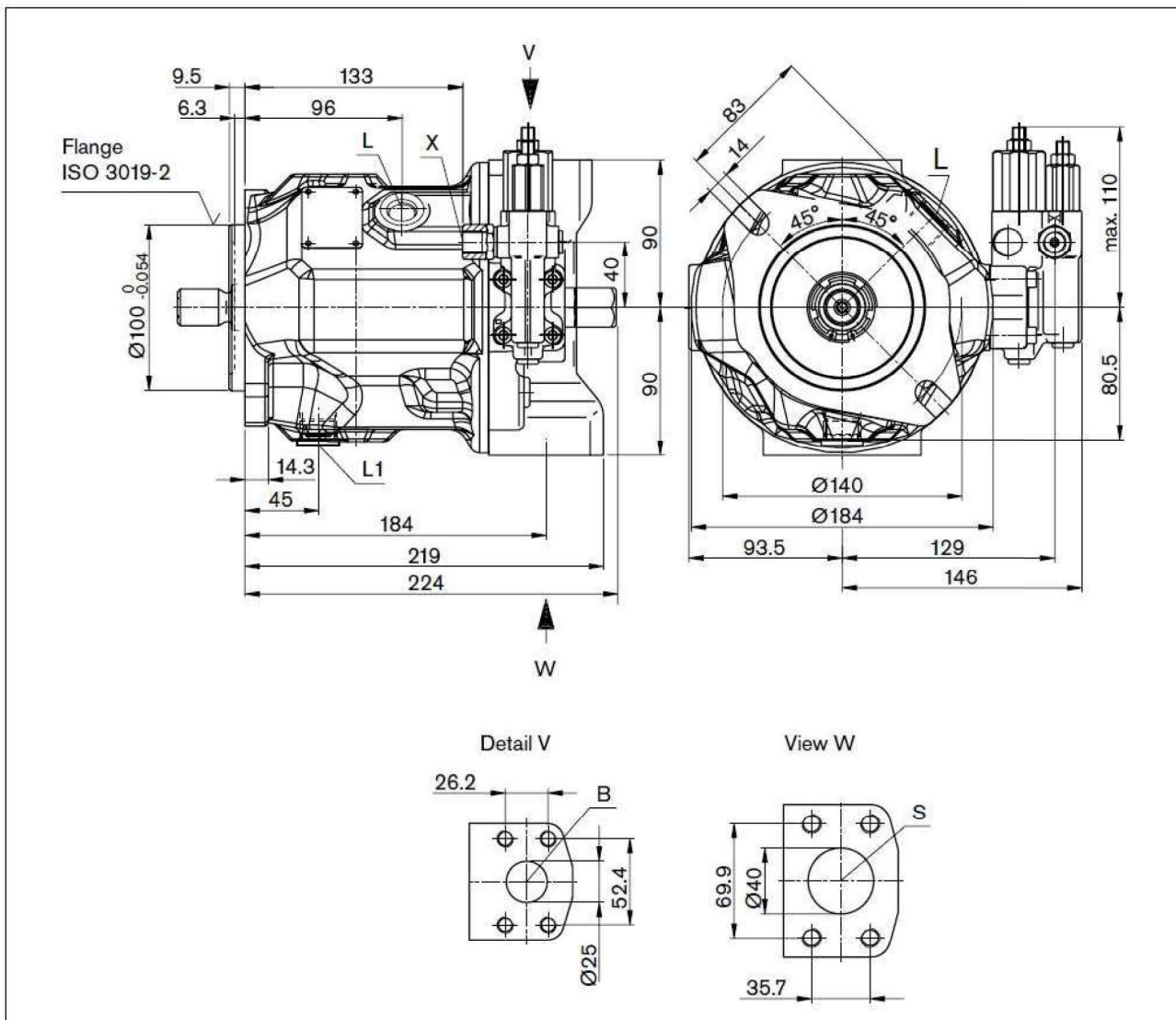

□ Ports:

Designation	Port for	Standard	Size	Maximum pressure (bar)	State
B	Service line fastening thread	SAE J518 DIN 13	1" M10 X 1.5 17 deep	350	O
S	Suction line fastening thread	SAE J518 DIN 13	1-1/2" M12 X 1.75 17 deep	10	O
L	Case drain fluid	DIN 3852	M22 X 1.5 12 deep	2	O
L ₁	Case drain fluid	DIN 3852	M22 X 1.5 12 deep	2	X
X	Pilot pressure	DIN 3852	M14 X 1.5 12 deep	350	O
X	Pilot pressure with DG-control	ISO 228	G 1/4" 12 deep	350	O

□ O = Must be connected (plugged on delivery)

□ X = Plugged (in normal operation)

■ Dimensions: Size 45

□ Drive shaft:

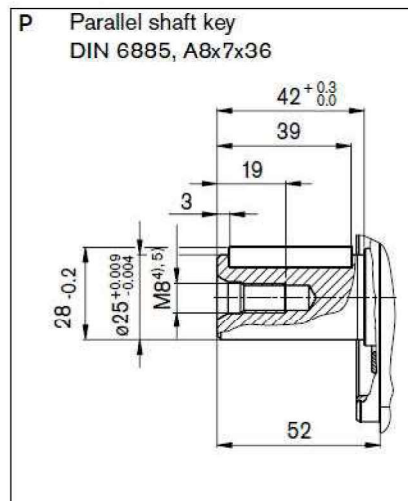
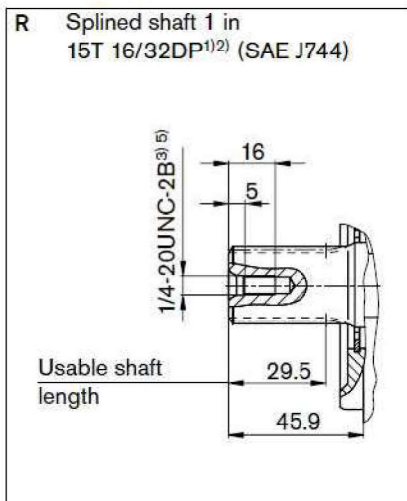
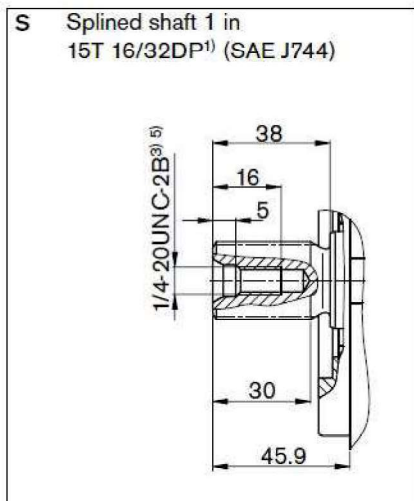

1) ANSI B92.1a, 30° pressure angle, flat root, side fit, tolerance class 5

2) Spline according to ANSI B92.1a, run out of spline is a deviation from standard.

3) Thread according to ASME B1.1

4) Thread according to DIN 13

5) For the maximum tightening torques the general instructions on [page 9](#) must be observed.

■ Dimensions: Size 45

DG

Two-point control, directly operated

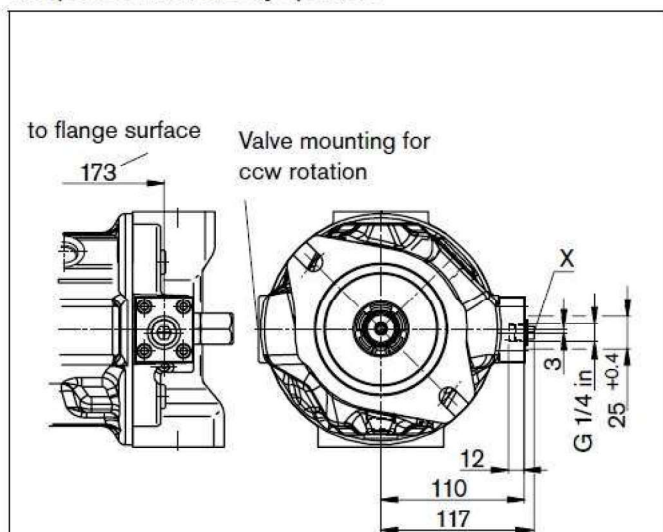

DFLR

Pressure, flow and power control

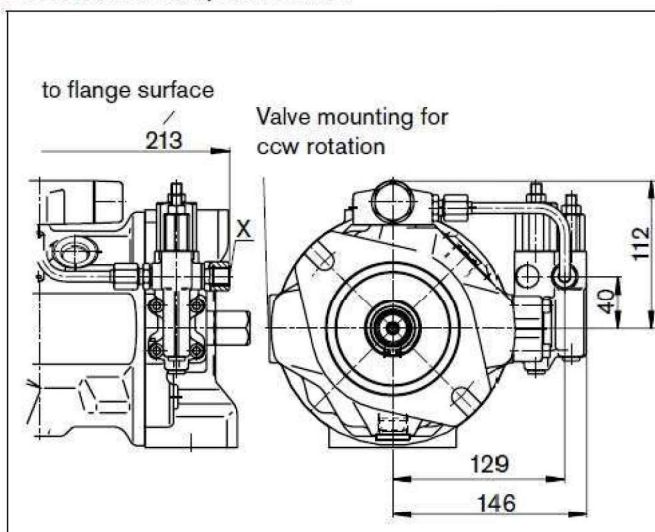

DR

Pressure control

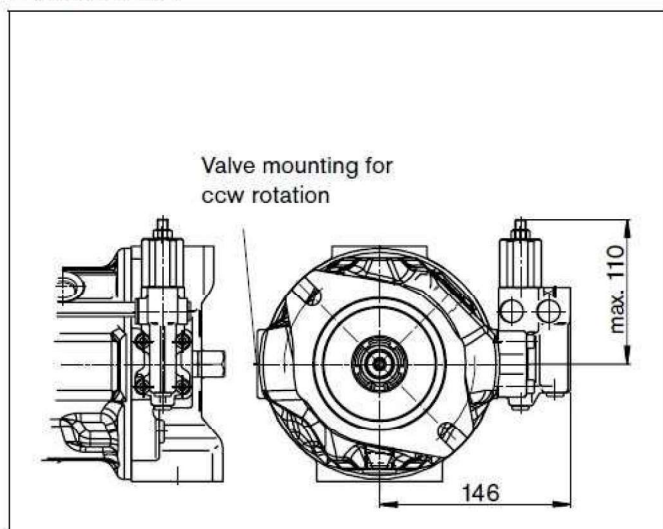

DRG

Pressure control, remotely operated

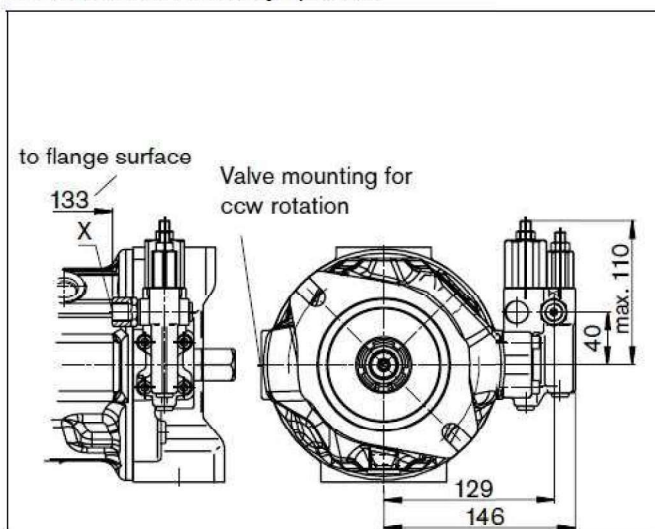

ED7. / ER7.

Electro-hydraulic pressure control

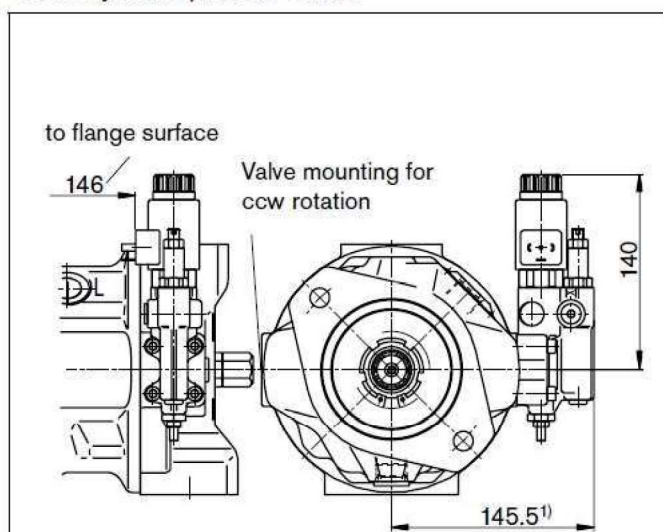

1) ER7.: 180.5 mm if using a sandwich plate pressure reducing valve.

■ Dimensions: Size 71

□ DFR/DFR1 – Pressure and flow control, hydraulic:

□ Clockwise rotation

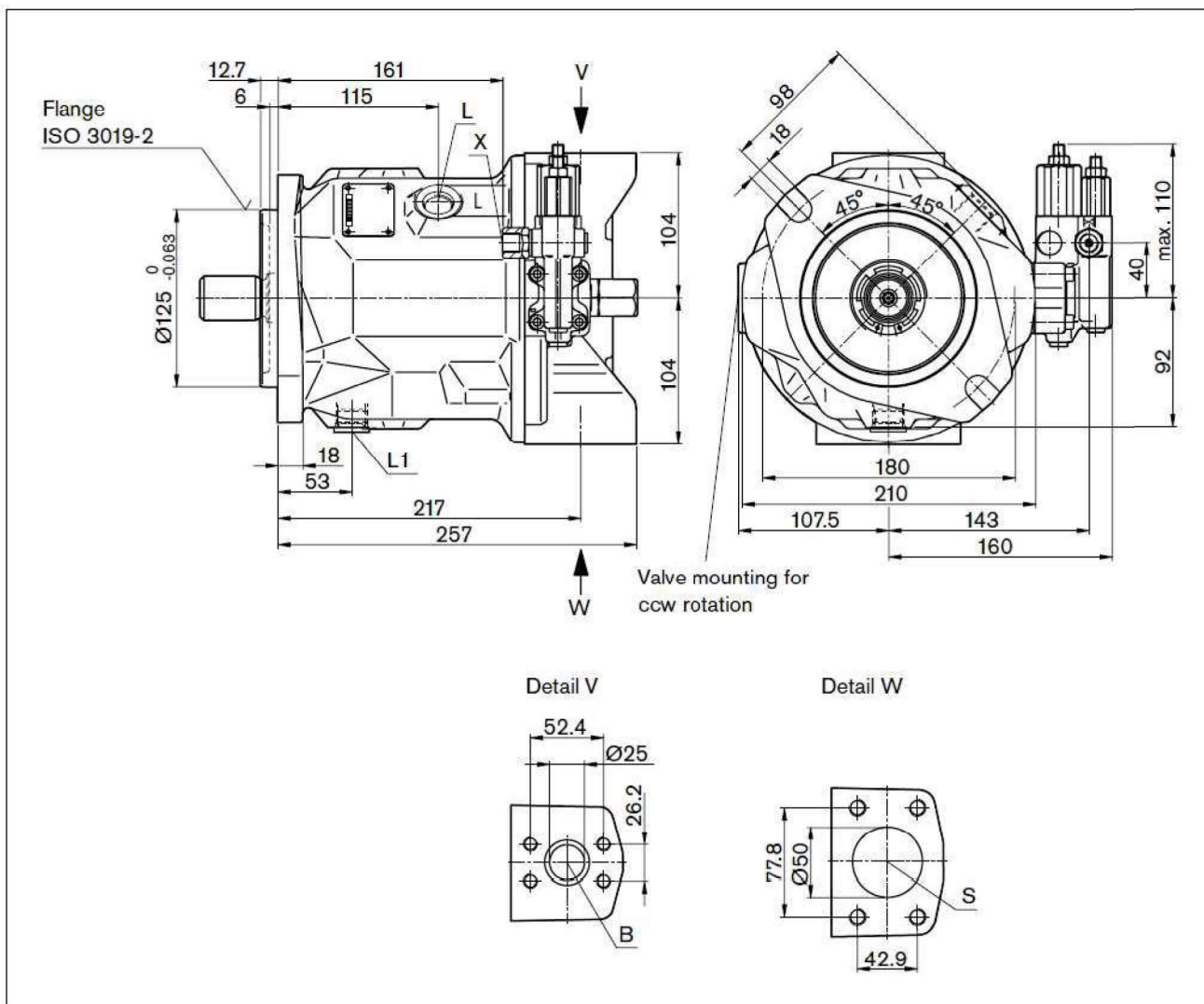

Designation	Port for	Standard	Size	Maximum pressure (bar)	State
B	Service line fastening thread	SAE J518 DIN 13	1" M10 X 1.5 17 deep	350	O
S	Suction line fastening thread	SAE J518 DIN 13	2" M12 X 1.75 20 deep	10	O
L	Case drain fluid	DIN 3852	M22 X 1.5 14 deep	2	O
L ₁	Case drain fluid	DIN 3852	M22 X 1.5 14 deep	2	X
X	Pilot pressure	DIN 3852	M14 X 1.5 12 deep	350	O
X	Pilot pressure with DG-control	ISO 228	G 1/4" 12 deep	350	O

- O = Must be connected (plugged on delivery)
- X = Plugged (in normal operation)

■ Dimensions: Size 71

□ Drive shaft:

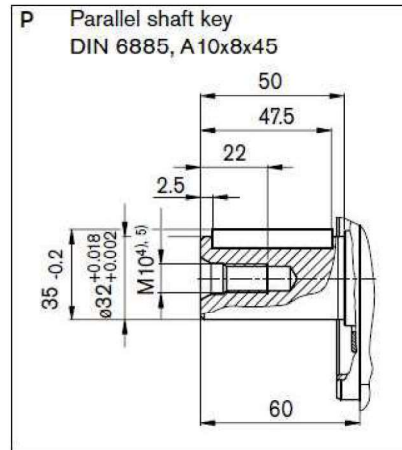
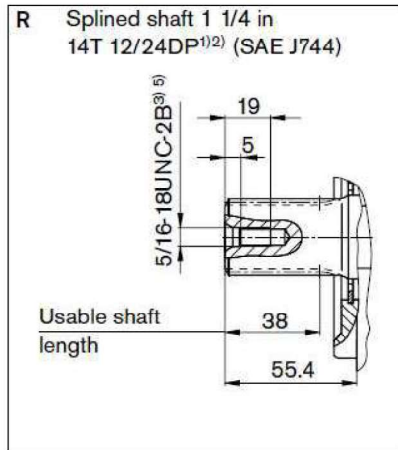
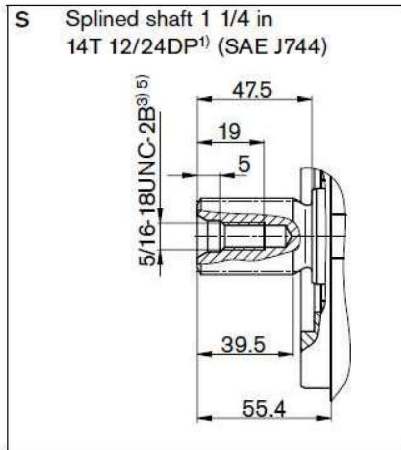

- 1) ANSI B92.1a, 30° pressure angle, flat root, side fit, tolerance class 5
- 2) Spline according to ANSI B92.1a, run out of spline is a deviation from standard.
- 3) Thread according to ASME B1.1
- 4) Thread according to DIN 13
- 5) For the maximum tightening torques the general instructions on page 9 must be observed.

■ Dimensions: Size 71

DG

Two-point control, directly operated

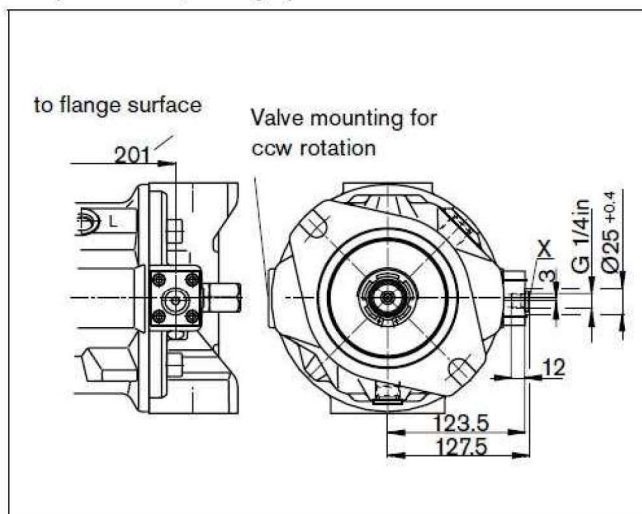

DFLR

Pressure, flow and power control

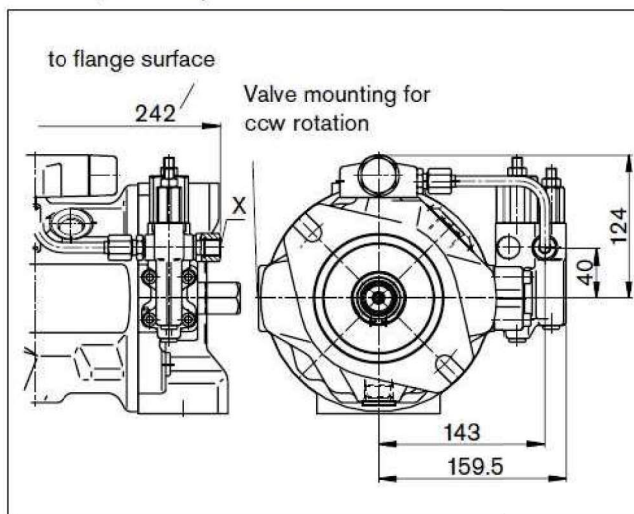

DR

Pressure control

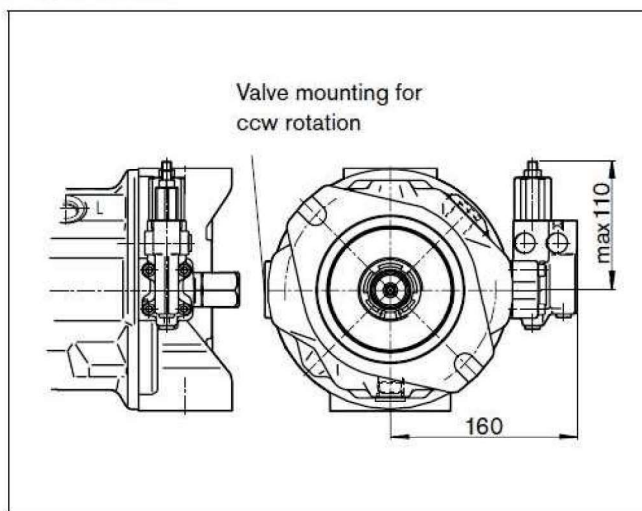

DRG

Pressure control, remotely operated

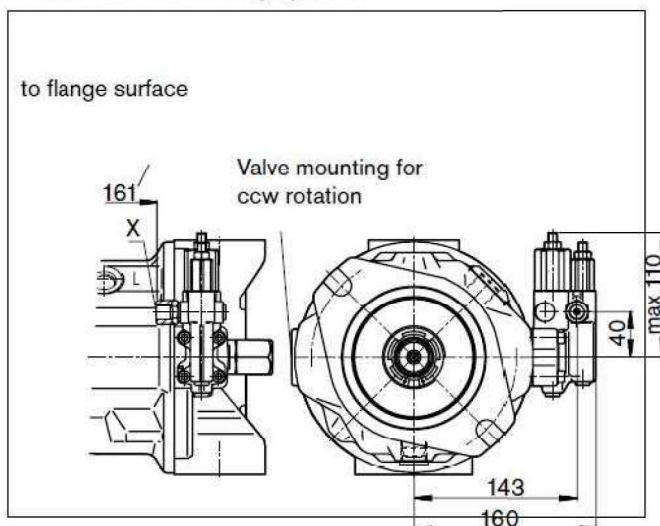

ED7. / ER7.

Electro-hydraulic pressure control

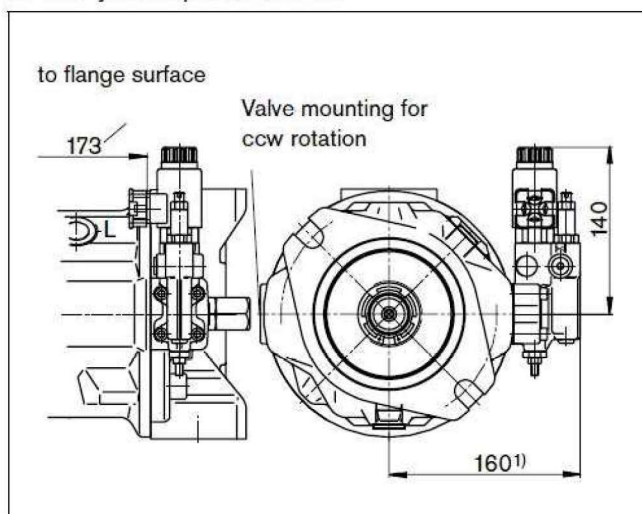

1) ER7.: 195 mm if using a sandwich plate pressure reducing valve.

■ Dimensions: Size 100

□ DFR/DFR1- Pressure and flow control, hydraulic:

□ Clockwise rotation

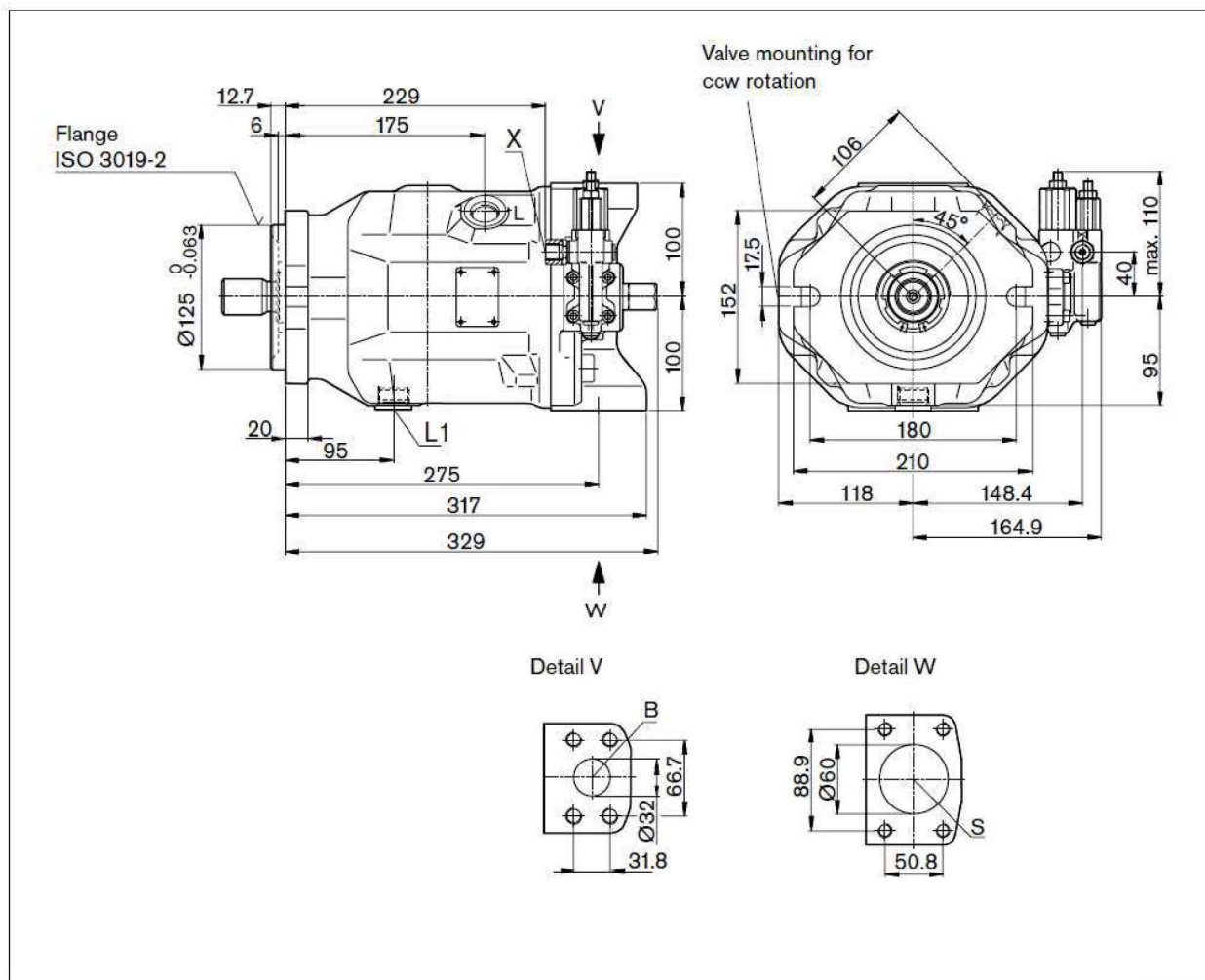

□ 油口尺寸:

Designation	Port for	Standard	Size	Maximum pressure (bar)	State
B	Service line fastening thread	SAE J518 DIN 13	1-1/4" M14 X 2 19 deep	350	O
S	Suction line fastening thread	SAE J518 DIN 13	2-1/2" M12 X 1.75 17 deep	10	O
L	Case drain fluid	DIN 3852	M27 X 2 16 deep	2	O
L ₁	Case drain fluid	DIN 3852	M27 X 2 16 deep	2	X
X	Pilot pressure	DIN 3852	M14 X 1.5 12 deep	350	O
X	Pilot pressure with DG-control	ISO 228	G 1/4" 12 deep	350	O

□ O = Must be connected (plugged on delivery)

□ X = Plugged (in normal operation)

■ Dimensions: Size 100

□ Drive shaft:

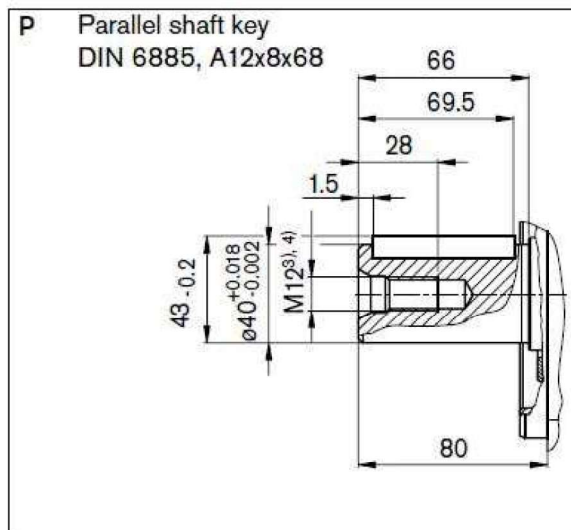
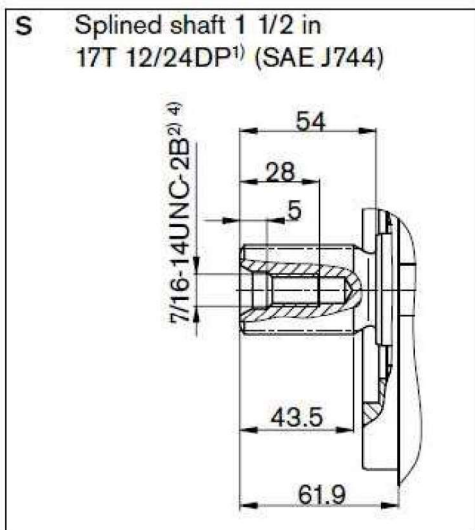

1) ANSI B92.1a, 30° pressure angle, flat root, side fit, tolerance class 5

2) Thread according to ASME B1.1

3) Thread according to DIN 13

4) For the maximum tightening torques the general instructions on page 9 must be observed.

■ Dimensions: Size 100

DG

Two-point control, directly operated

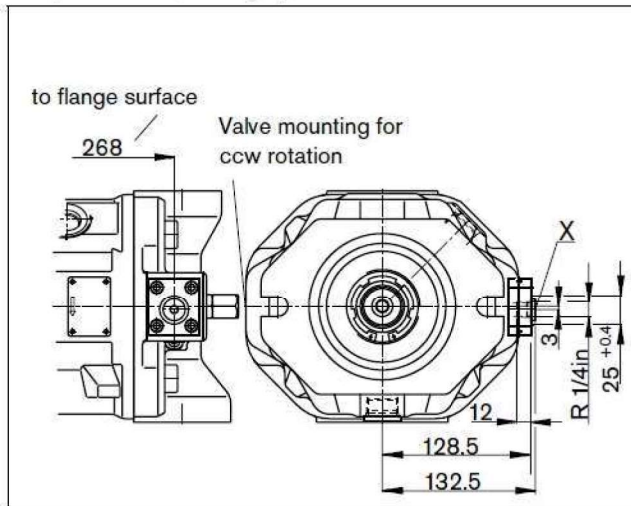

DFLR

Pressure, flow and power control

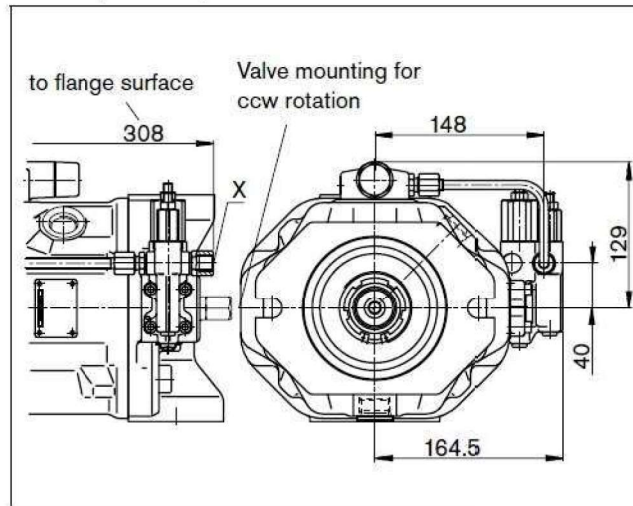

DR

Pressure control

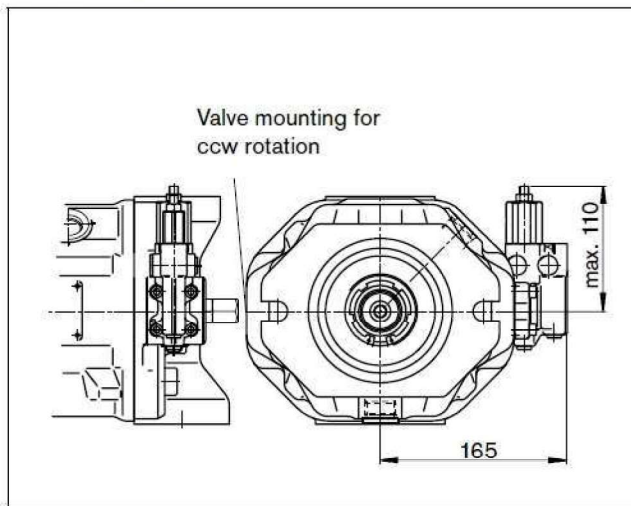

DRG

Pressure control, remotely operated

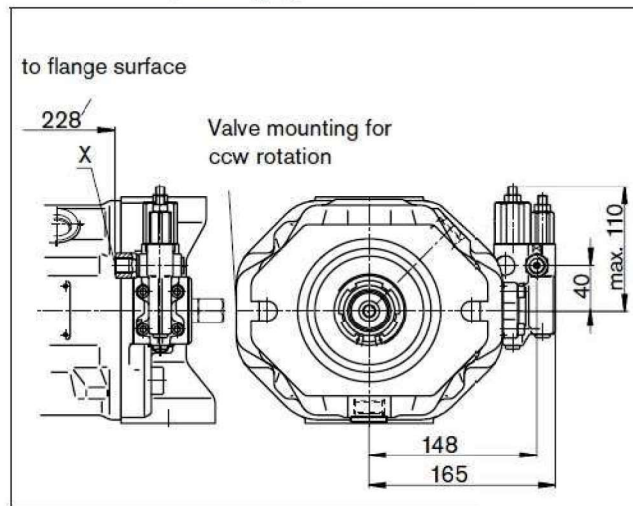

ED7. / ER7.

Electro-hydraulic pressure control

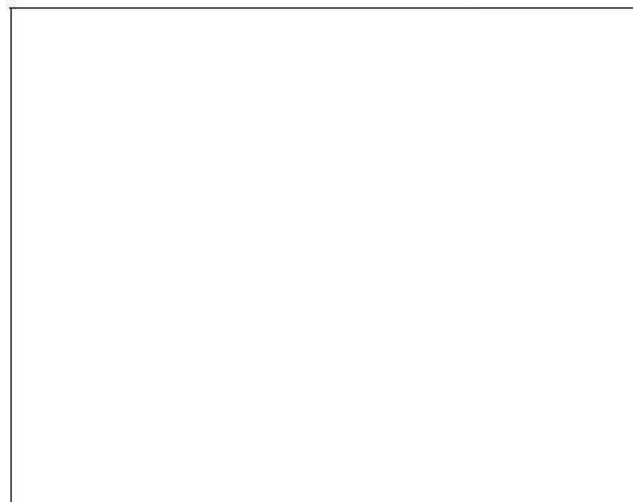
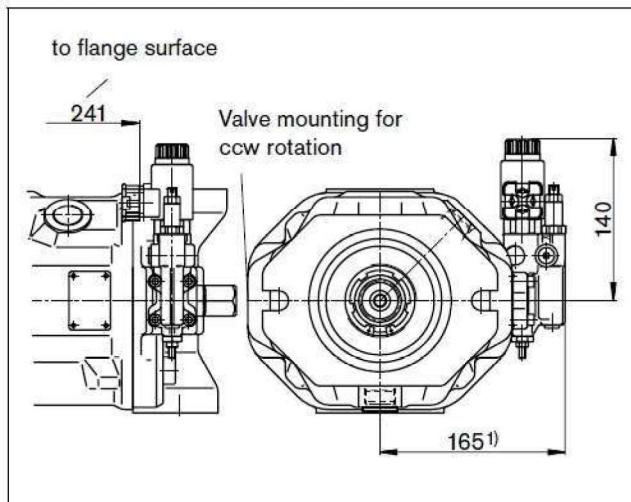

1) ER7. : 200 mm when using a sandwich plate pressure reducing valve.

■ Dimensions: Size 140

□ DFR/DFR1- Pressure and flow control, hydraulic

□ Clockwise rotation

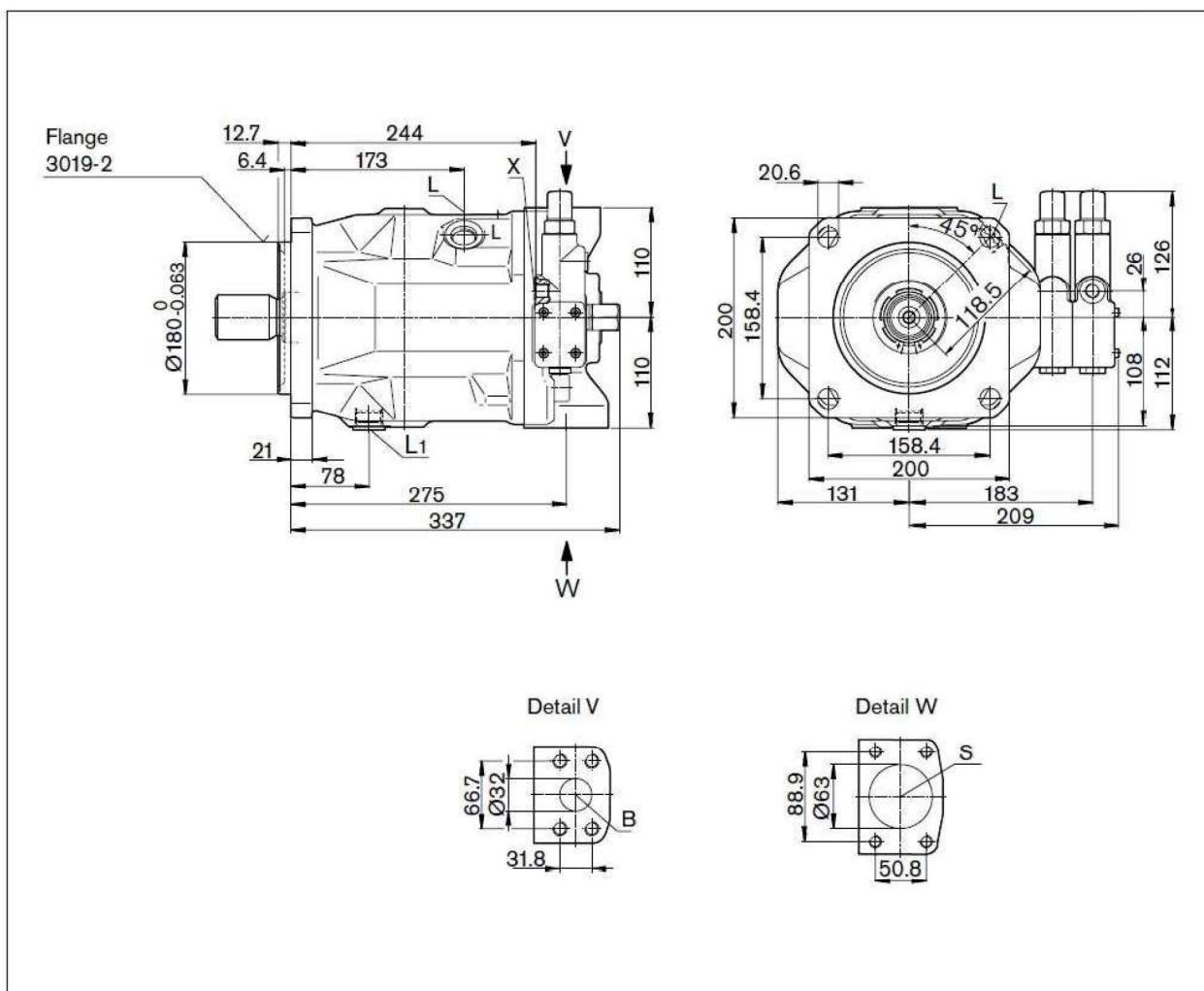

□ Ports:

Designation	Port for	Standard	Size	Maximum pressure (bar)	State
B	Service line fastening thread	SAE J518 DIN 13	1-1/4" M14 X 2 19 deep	350	O
S	Suction line fastening thread	SAE J518 DIN 13	2-1/2" M12 X 1.75 17 deep	10	O
L	Case drain fluid	DIN 3852	M27 X 2 16 deep	2	O
L ₁	Case drain fluid	DIN 3852	M27 X 2 16 deep	2	X
X	Pilot pressure	DIN 3852	M14 X 1.5 12 deep	350	O
X	Pilot pressure with DG-control	DIN 3852	M14 X 1.5 12 deep	350	O
M _H	Gauge port, high pressure	DIN 3852	M14 X 1.5 12 deep	350	X

□ O = Must be connected (plugged on delivery)

□ X = Plugged (in normal operation)

■ Dimensions: Size140

□ Drive shaft:

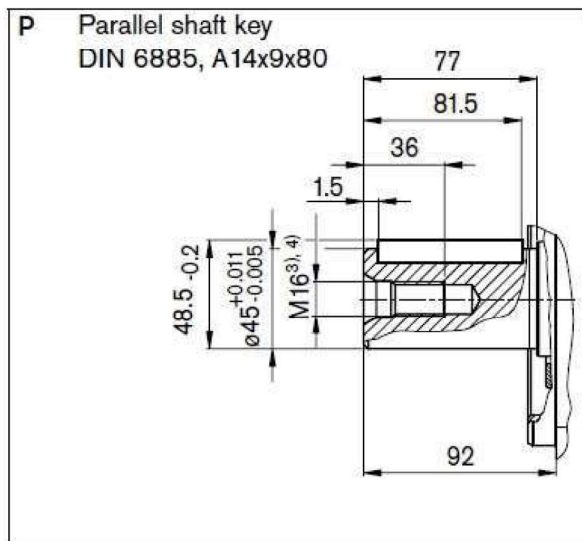
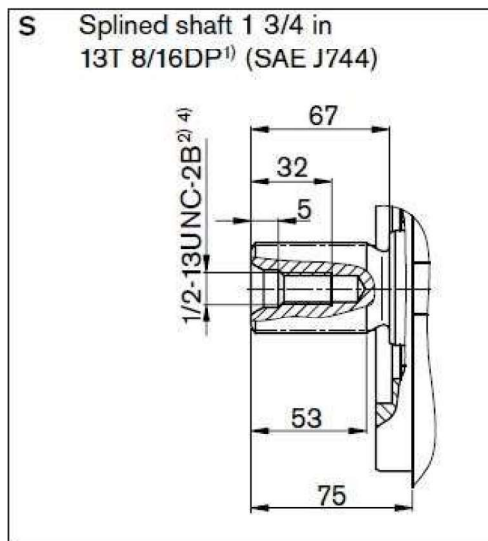

1) ANSI B92.1a, 30° pressure angle, flat root, side fit, tolerance class 5

2) Thread according to ASME B1.1

3) Thread according to DIN 13

4) For the maximum tightening torques the general instructions on page 9 must be observed.

■ Dimensions: Size 140

DG

Two-point control, directly operated

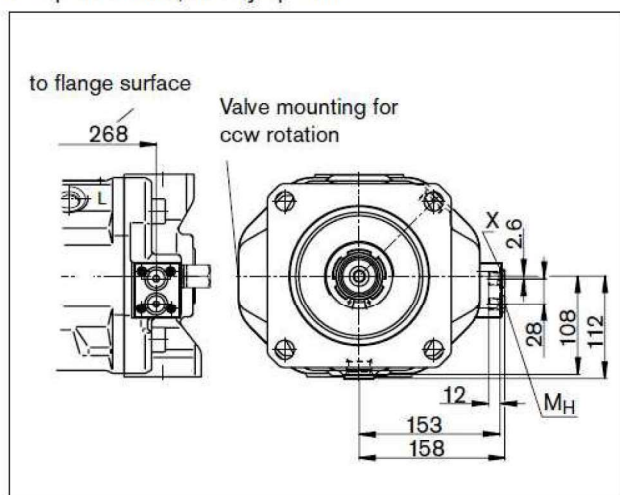

DFLR

Pressure, flow and power control

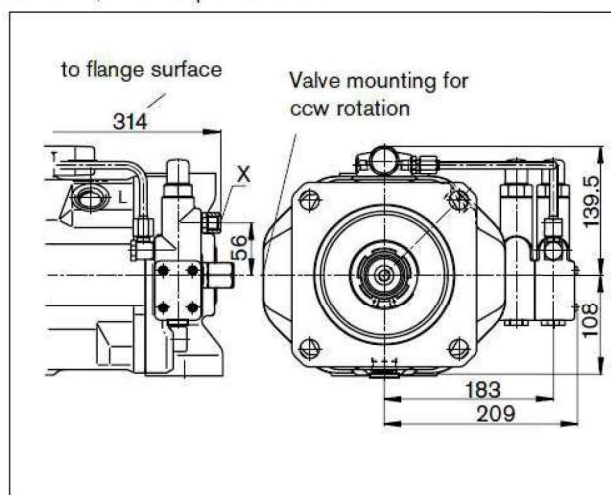

DR

Pressure control

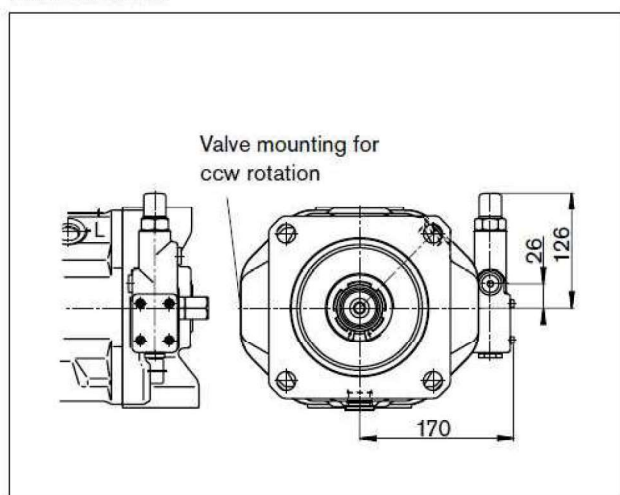

DRG

Pressure control, remotely operated

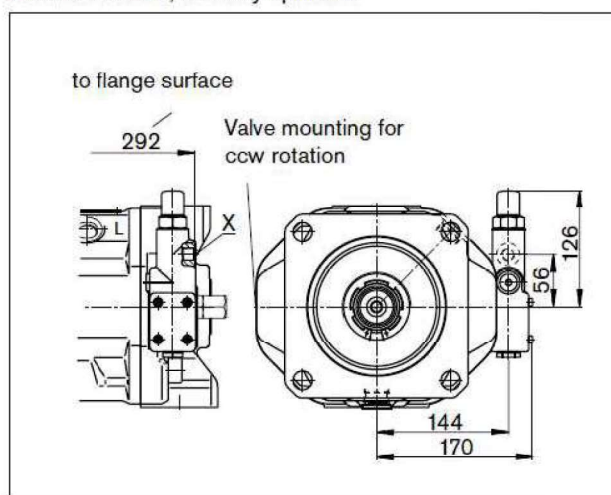

ED7. / ER7.

Electro-hydraulic pressure control

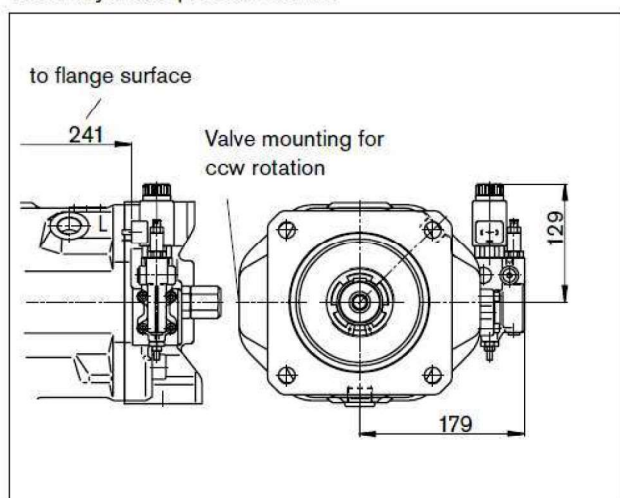

1) ER7. : 214 mm when using a sandwich plate pressure reducing valve.

■ Type Code For Standard Program:

AH		10V	O	100	DR	/	31	R	-	P	S	C	11	N00
0	1	2	3	4	5	6	7	8	9	10	11	12		

0. Supplier:

ACCESSHYDRO

1. Hydraulic fluid / Version:

Hydraulic fluid / Version:	18	28	45	71	100	140	Code
Mineral oil and HFD-fluids.....no code	■	■	■	■	■	■	-
High-Speed-Version	-	-	□	□	□	■	H

2. Axial piston unit:

Axial piston unit / Version:	18	28	45	71	100	140	Code
Swash plate design, variable, up to industrial grade	■	-	-	-	-	-	AH10VS
Nominal pressure 280 bar, Peak pressure 350 bar	-	■	■	■	■	■	AH10V

3. Type of operation:

Type of operation / Version:	18	28	45	71	100	140	Code
Pump, open circuit	■	■	■	■	■	■	O

4. Size:

Size / Version:	18	28	45	71*	100	140	Code
Size \cong Vgmax (cm ³ /r)	18	28	45	71	100	140	-

5. Control devices:

Control devices / Version:	18	28	45	71	100	140	Code	
Two-point control, directly operated	■	■	■	■	■	■	DG	
Pressure control	■	■	■	■	■	■	DR	
Pressure control...remotely operated	■	■	■	■	■	■	DRG	
Pressure-flow control	■	■	■	■	■	■	DFR	
Pressure-flow control...X-T plugged	■	■	■	■	■	■	DFR1	
Pressure/Flow/Power control	■	■	■	■	■	■	DFLR	
Electro-proportional control with flow control	-	□	□	□	□	□	EF	
Electro-hydraulic pressure control	negative characteristic	12V	□	□	□	□	□	ED71
		24V	□	□	□	□	□	ED72
	positive characteristic	12V	□	□	□	□	□	ER71
		24V	□	□	□	□	□	ER72

■ Type Code For Standard Program:

6. Series:

Series / Version:	18	28	45	71	100	140	Code
31 Series	■	■	■	■	■	■	31

7. Direction of rotation:

Direction of rotation:		Code
With view on shaft end	Clockwise(forward dextral)	R
	Counter-clockwise (reverse left-handed)	L

8. Seals:

Seals / Version	18	28	45	71	100	140	Code
NBR (Nitrile-rubber DIN ISO 1629), with shaft seal FKM	■	■	■	■	■	■	P
FKM (Fluoro-rubber DIN ISO 1629)	■	■	■	■	■	■	V

9. Shaft end:

Shaft end / Version:		18	28	45	71	100	140	Code
Splined shaft SAE	standard shaft	■	■	■	■	■	■	S
	similar to shaft , S “ however for higher input torque	■	■	■	■	-	-	R
ANSI B92.1a	reduced diameter, not for through drive	■	■	■	■	■	□	U
	similar to shaft "U", however for higher torque	-	■	■	■	■	□	W

10. Mounting flange:

Mounting flange / Version:		18	28	45	71	100	140	Code
ISO 3019-1 SAE	2-hole	■	■	■	■	■	■	C
	4-hole	-	-	-	-	□	■	D

11. Service line connections:

Service line connections / Version:		18	28	45	71	100	140	Code
Port B and S at rear		-	■	■	-	■	■	11
SAE flange port at rear, metric fixing thread (not for through drive)		-	-	-	■	-	-	41
Port B and S at rear, on opposite side		■	■	■	-	■	■	12
SAE flange port at rear, metric fixing thread (not for through drive)		-	-	-	■	-	-	42

■ Type Code For Standard Program:

12. Through drive:

Through drive / Version:			18	28	45	71	100	140	Code
without through drive			■	■	■	■	■	■	N00
with through drive for mounting an axial piston unit, gear or radial piston pump									
Flange	coupling for splined shaft		18	28	45	71	100	140	Code
Flange ISO 3019-1	Diameter ANSI B92.1a								
82-2 (A)	5/8"	9T 16/32 DP	■	■	■	■	■	■	K01
	3/4"	11T 16/32 DP	■	■	■	■	■	■	K52
101-2 (B)	7/8"	13T 16/32 DP	-	■	■	■	■	■	K68
	1"	15T 16/32 DP	-	-	■	■	■	■	K04
127-2 (C)	1-1/4"	14T 12/24 DP	-	-	-	■	■	■	K07
	1-1/2"	17T 12/24 DP	-	-	-	-	■	■	K24
152-4 (D)	1-3/4"	13T 8/16 DP	-	-	-	-	-	■	K17

 = Preferred Program

■ = Available

□ = On request

- = Not Available

■ **Technical Data:**

- Applies to mineral oil medium run
- **Operating pressure range:**
- Pressure at service line port (pressure port) B:
 Nominal pressure P_{nom} ----- 280 bar
 Peak pressure P_{max} ----- 350 bar
- Single operating period 2.0 ms
- Total operating period 300 h
- Minimum pressure (high-pressure side): 10 bar absolute
- Rate of pressure change $R_{A,max}$: 16000 bar/s

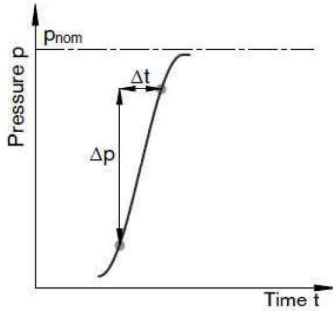

- Pressure at suction port S (inlet):
- Minimum pressure $P_{S,min}$ ----- 0.8 bar...绝对压力
- Maximum pressure $P_{S,max}$ ----- 10 bar

■ **Case drain pressure:**

- The lower the input speed and the case drain pressure, the longer the service life of the shaft end seal.
- Maximum permissible case drain pressure (at port L, L1)
 Maximum 0.5 bar higher than the inlet pressure at port S, however not higher than 2 bar absolute.
- $P_{L,max}$ ----- 2 bar...absolute

■ **Definition:**

■ **Nominal pressure P_{nom}**

The nominal pressure corresponds to the maximum design pressure.

□ **Peak pressure P_{max}**

The peak pressure corresponds the maximum operating pressure within the single operating period. The sum of the single operating periods must not exceed the total operating period.

□ **Minimum pressure (high-pressure side):**

Minimum pressure on the high-pressure side (B) that is required in order to prevent damage to the axial piston unit.

□ **Rate of pressure change R_A**

Maximum permissible rate of pressure build-up and pressure reduction during a pressure change over the entire pressure range.

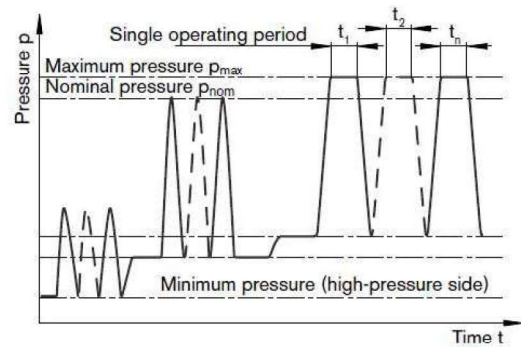

Total operating period = $t_1 + t_2 + t_3 + \dots + t_n$

■ Technical data:

□ Standard Program, applies to mineral oil medium run

□ Table of values: (theoretical values, without efficiencies and tolerances: values rounded)

Size	NG	Size	18	28	45	71	100	140
Geometrical displacement per revolution		$V_{g \max}$ cm ³	18	28	45	71	100	140
Maximum speed ¹⁾								
at $V_{g \max}$	n_{nom} rpm		3300	3000	2600	2200	2000	1800
at $V_g < V_{g \max}$	$n_{\text{max perm}}$ rpm		3900	3600	3100	2600	2400	2100
Flow								
at n_{nom} and $V_{g \max}$	$q_{v \max}$ l/min		59	84	117	156	200	252
at $n_E = 1500$ rpm and $V_{g \max}$	$q_{vE \max}$ l/min		27	42	68	107	150	210
Power at $\Delta p = 280$ bar								
at n_{nom} , $V_{g \max}$	P_{\max} kW		30	39	55	73	93	118
at $n_E = 1500$ rpm and $V_{g \max}$	$P_{E \max}$ kW		12.6	20	32	50	70	98
Torque								
at $V_{g \max}$ and	$\Delta p = 280$ bar	T_{\max} Nm	80	125	200	316	445	623
	$\Delta p = 100$ bar	T Nm	30	45	72	113	159	223
Rotary stiffness, drive shaft	S	c Nm/rad	11087	22317	37500	71884	121142	169537
	R	c Nm/rad	14850	26360	41025	76545	–	–
	U	c Nm/rad	8090	16695	30077	52779	91093	–
	W	c Nm/rad	–	19898	34463	57460	101847	–
Moment of inertial rotary group	J_{TW} kgm ²		0.00093	0.0017	0.0033	0.0083	0.0167	0.0242
Angular acceleration, maximum ²⁾	α rad/s ²		6800	5500	4000	3300	2700	2700
Filling capacity	V L		0.4	0.7	1.0	1.6	2.2	3.0
Weight (without through drive) approx.	m kg		12	15	21	33	45	60

1) The values are applicable:

- ✚ for absolute pressure $P_{\text{abs}} = 1$ bar at the suction port S;
- ✚ for the optimum viscosity range of $v_{\text{opt}} = 16$ to 36 mm²/s
- ✚ for mineral-based operating materials

2) The scope of application lies between the minimum necessary and the maximum permissible drive speeds:

- ✚ Valid for external excitation;
- ✚ The limiting value is only valid for a single pump;
- ✚ The loading capacity of the connecting parts must be taken into account.
- ✚ If the drive speed continuous increasing and up to the limit speed, please conform to the curves shows.

□ Notes:

✚ Exceeding the maximum or falling below the minimum permissible values can lead to a loss of function, a reduction in operational service life or total destruction of the axial piston unit.

✚ We recommend checking the loading with tests or calculations / simulations and comparison with the permissible values.

□ Determination of size:

Flow	$q_v = \frac{V_g \cdot n \cdot \eta_v}{1000}$	[l/min]	V_g = Displacement per revolution in cm ³
			Δp = Pressure differential in bar
Torque	$T = \frac{V_g \cdot \Delta p}{20 \cdot \pi \cdot \eta_{mh}}$	[Nm]	n = Speed in rpm
			η_v = Volumetric efficiency
Power	$P = \frac{2\pi \cdot T \cdot n}{60000} = \frac{q_v \cdot \Delta p}{600 \cdot \eta_t}$	[kW]	η_{mh} = Mechanical-hydraulic efficiency
			η_t = Total efficiency ($\eta_t = \eta_v \cdot \eta_{mh}$)

■ Technical Data:

□ High- speed version, applies to mineral oil medium run

□ Table of values: (theoretical values, without efficiencies and tolerances: values rounded)

Size	NG			45	71	100	140
Geometrical displacement per revolution							
	$V_{g \max}$	cm ³		45	71	100	140
Maximum speed ¹⁾							
at $V_{g \max}$	n_{nom}	rpm		3000	2550	2300	2050
at $V_g < V_{g \max}$	$n_{\text{max perm}}$	rpm		3300	2800	2500	2200
Flow							
at n_{nom} and $V_{g \max}$	$q_{v \max}$	l/min		135	178	230	287
Power at $\Delta p = 280$ bar							
at $n_{\text{nom}}, V_{g \max}$	P_{max}	kW		63	83	107	134
Torque							
at $V_{g \max}$ and	$\Delta p = 280$ bar	T_{max}	Nm	200	316	445	623
	$\Delta p = 100$ bar	T	Nm	72	113	159	223
Rotary stiffness, drive shaft	S	c	Nm/rad	37500	71884	121142	169537
	R	c	Nm/rad	41025	76545	–	–
	U	c	Nm/rad	30077	52779	91093	–
	W	c	Nm/rad	34463	57460	101847	–
Moment of inertial rotary group		J_{TW}	kgm ²	0.0033	0.0083	0.0167	0.0242
Angular acceleration, maximum ²⁾		α	rad/s ²	4000	3300	2700	2700
Filling capacity		V	L	1.0	1.6	2.2	3.0
Weight (without through drive) approx.		m	kg	21	33	45	60

1) The values are applicable:

- ✚ for absolute pressure $p_{\text{abs}} = 1$ bar at the suction port S;
- ✚ for the optimum viscosity range of $\nu_{\text{opt}} = 16$ to 36 mm²/s
- ✚ for mineral-based operating materials

2) The scope of application lies between the minimum necessary and the maximum permissible drive speeds:

- ✚ Valid for external excitation;
- ✚ The limiting value is only valid for a single pump;
- ✚ The loading capacity of the connecting parts must be taken into account.
- ✚ If the drive speed continuously increasing and up to the limit speed, please conform to the curves shows.

□ Notes:

- ✚ Exceeding the maximum or falling below the minimum permissible values can lead to a loss of function, a reduction in operational service life or total destruction of the axial piston unit.
- ✚ We recommend checking the loading with tests or calculations / simulations and comparison with the permissible values.

□ Recommendation:

Sizes 45, 71, 100 and 140 are optionally available in high-speed version.

External dimensions are not affected by this option.

■ Technical Data:

□ Permissible radial and axial loading on the drive shaft

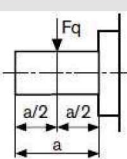
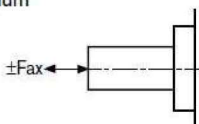
Size	NG	18	28	45	71	100	140		
Radial force maximum at $a/2$		$F_{q \max}$	N	350	1200	1500	1900	2300	2800
Axial force maximum		$\pm F_{ax}$	N	700	1000	1500	2400	4000	4800

□ Permissible input and through-drive torques

Size	NG	18	28	45	71	100	140	
Torque at $V_{g \max}$ and $\Delta p = 280 \text{ bar}^1$	T_{\max}	Nm	80	125	200	316	445	623
Input torque for drive shaft, maximum ²⁾								
S	$T_{E \max}$	Nm	124	198	319	626	1104	1620
	\varnothing	in	3/4	7/8	1	1 1/4	1 1/2	1 3/4
R	$T_{E \max}$	Nm	160	250	400	644	–	–
	\varnothing	in	3/4	7/8	1	1 1/4	–	–
U	$T_{E \max}$	Nm	59	105	188	300	595	–
	\varnothing	in	5/8	3/4	7/8	1	1 1/4	–
W	$T_{E \max}$	Nm	–	140	220	394	636	–
	\varnothing	in	–	3/4	7/8	1	1 1/4	–
Maximum through-drive torque for drive shaft								
S	$T_{D \max}$	Nm	108	160	319	492	778	1266
R	$T_{D \max}$	Nm	120	176	365	548	–	–

□ Distribution of torques:

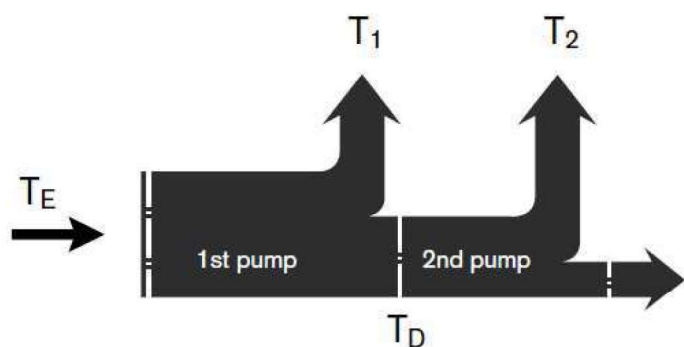

■ Drive power and flow:

□ Hydraulic fluid ISO VG 46 DIN 51519, $t = 50\text{ }^\circ\text{C}$

□ Size 18

----- $n = 1500\text{ rpm}$
 _____ $n = 3300\text{ rpm}$

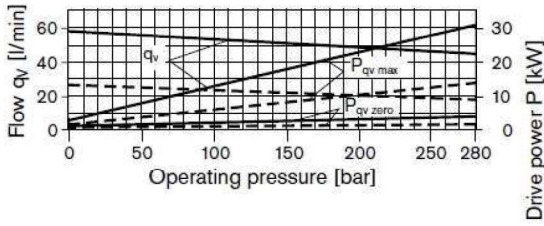

□ Size 28

----- $n = 1500\text{ rpm}$
 _____ $n = 3000\text{ rpm}$

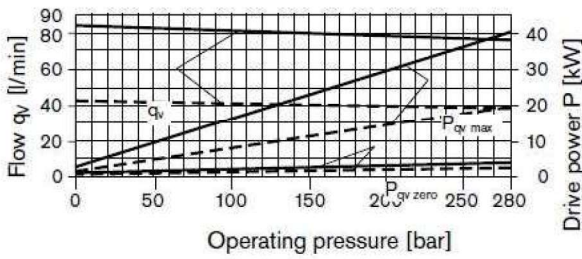

□ Size 45

----- $n = 1500\text{ rpm}$
 _____ $n = 2600\text{ rpm}$

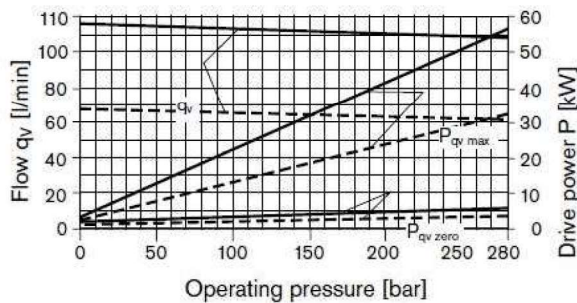

□ Size 71

----- $n = 1500\text{ rpm}$
 _____ $n = 2200\text{ rpm}$

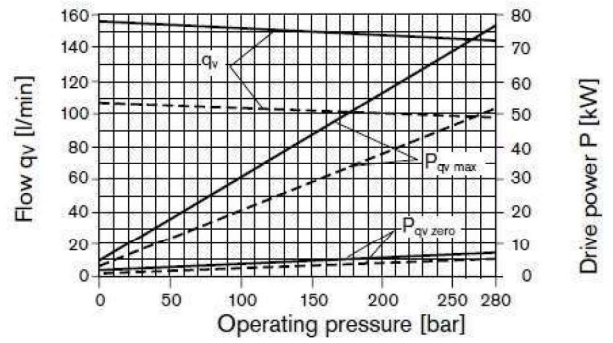

□ Size 100

----- $n = 1500\text{ rpm}$
 _____ $n = 2000\text{ rpm}$

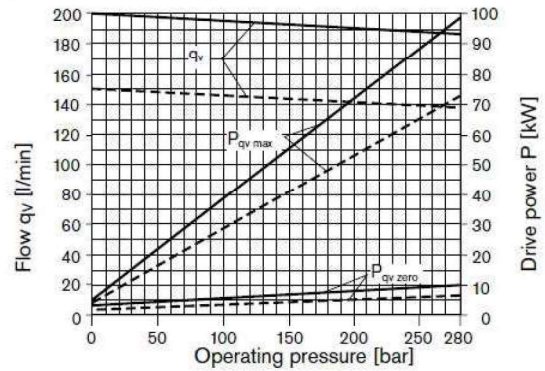

□ Size 140

----- $n = 1500\text{ rpm}$
 _____ $n = 1800\text{ rpm}$

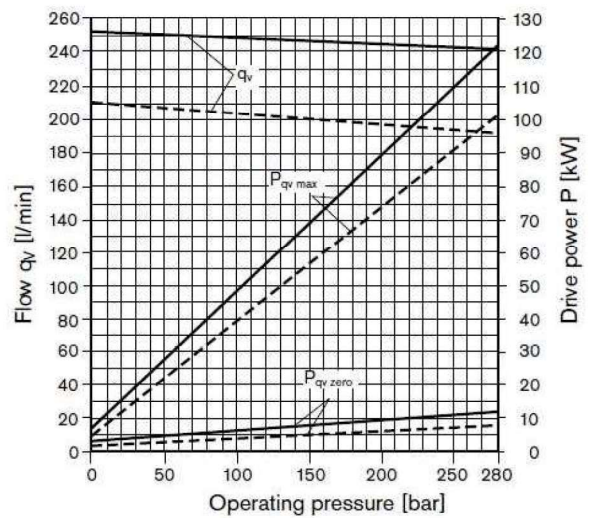

■ DG - Two-point control, directly operated

- Two-point control, directly operated
- Refer to AH10VSO on page 12 .

■ DR - Pressure control:

- Constant pressure control
- Refer to AH10VSO on page 13

■ DRG - Pressure control, remotely operated

- Pressure control, remotely operated
- Refer to AH10VSO on page 14

■ DFR/DFR1- Pressure and flow control:

- Constant flow control
- Refer to AH10VSO on page 15

■ DFLR - Pressure, flow and power control:

- Constant power control
- Refer to AH10VSO on page 16

■ ED - Electro-hydraulic pressure control

- Electro-hydraulic pressure control...negative characteristic
- Refer to AH10VSO on page 18

■ ER - Electro-hydraulic pressure control

- Electro-hydraulic pressure control ...positive characteristic
- Refer to AH10VSO on page 19

■ Dimensions: Size 18

- DFR/DFR1 - Pressure and flow control, hydraulic:
- Clockwise rotation

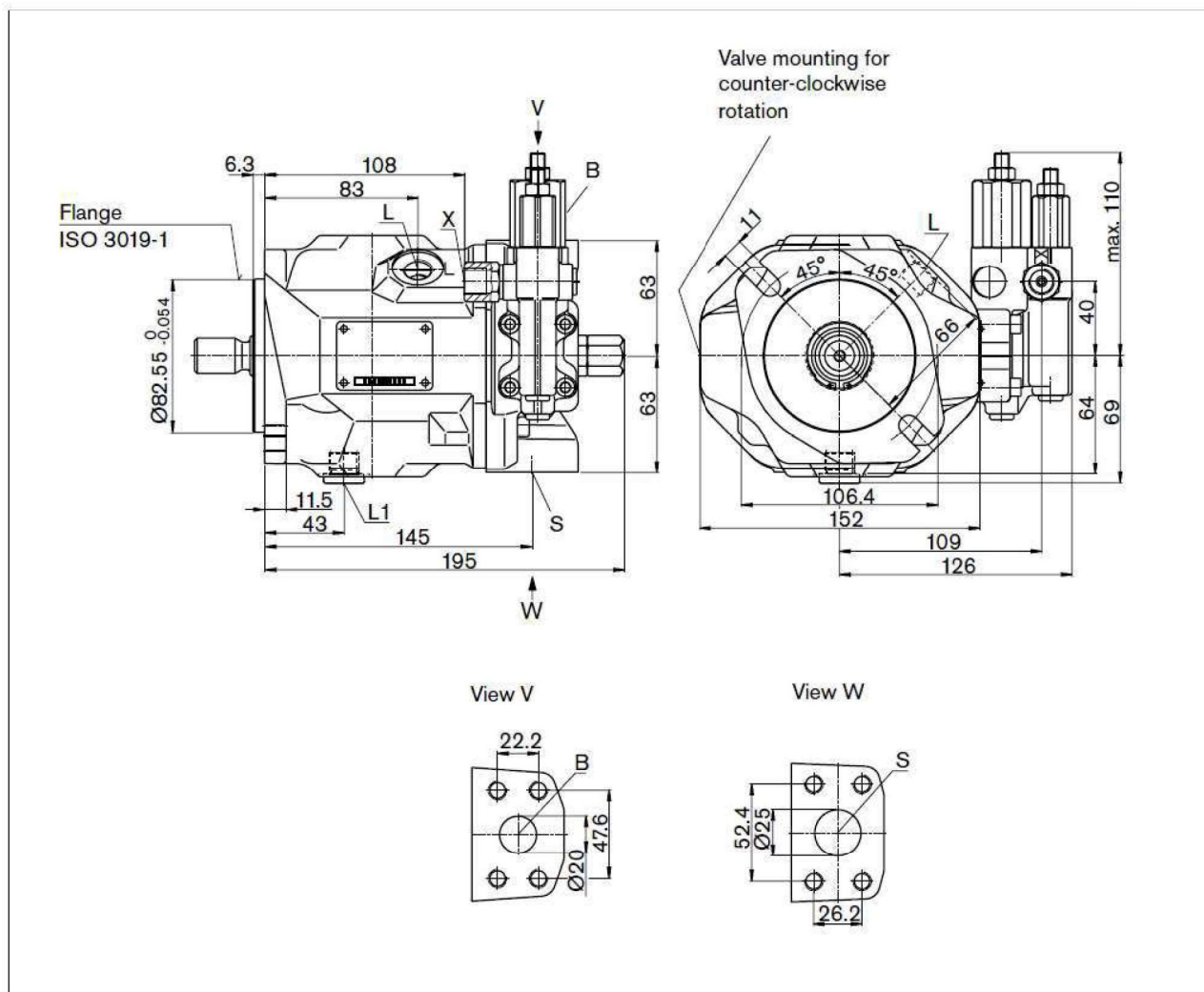

□ Ports:

Designation	Port for	Standard	Size	Maximum pressure (bar)	State
B	Service line fastening thread	SAE J518 DIN 13	3/4" M10 X 1.5 17 deep	350	O
S	Suction line fastening thread	SAE J518 DIN 13	1" M10 X 1.5 17 deep	10	O
L	Case drain fluid	DIN 3852	M16 X 1.5 12 deep	2	O
L ₁	Case drain fluid	DIN 3852	M16 X 1.5 12 deep	2	X
X	Pilot pressure	DIN 3852	M14 X 1.5 12 deep	350	O
X	Pilot pressure with DG-control	ISO 228	G 1/4" 12 deep	350	O

- O = Must be connected (plugged on delivery)
- X = Plugged (in normal operation)

■ Dimensions: Size 18

□ Drive shaft:

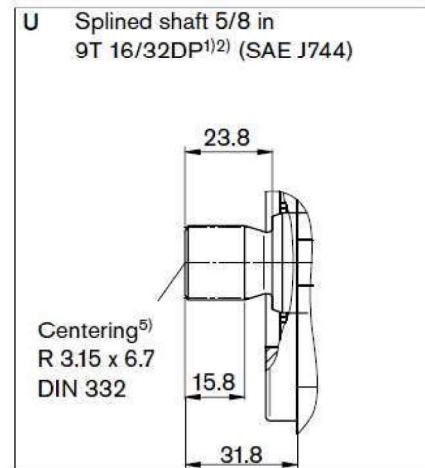
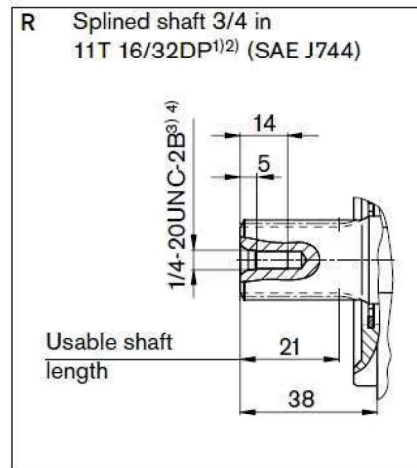
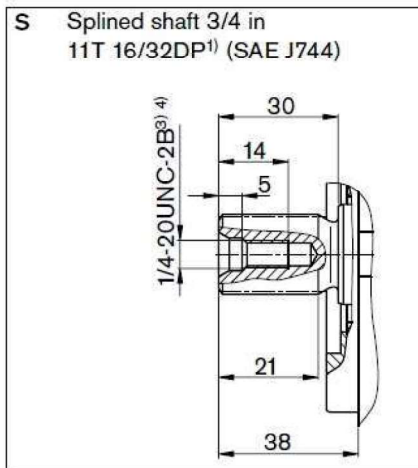

1) ANSI B92.1a, 30° pressure angle, flat root, side fit, tolerance class 5

2) Splines according to ANSI B92.1a, run out of spline is a deviation from standard

3) Thread according to ASME B1.1

4) For the maximum tightening torques the general instructions on page 48 must be observed

5) Coupling axially secured, e.g. with a clamp coupling or radially mounted clamping screw

■ Dimensions: Size 18

DG

Two-point control, directly operated

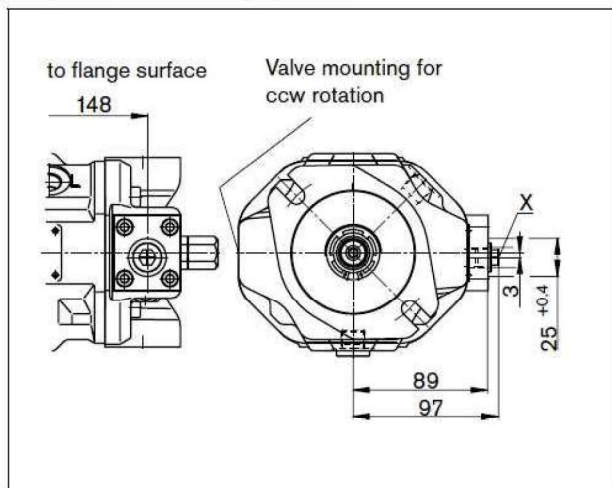

DR

Pressure control

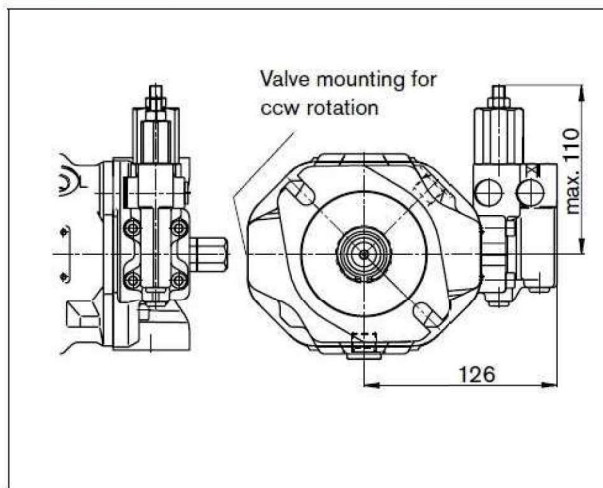

DRG

Pressure control, remotely operated

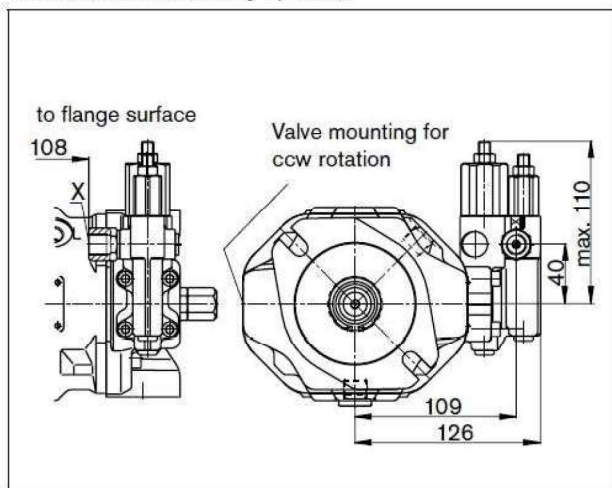

ED7., ER7.

Electro-hydraulic pressure control

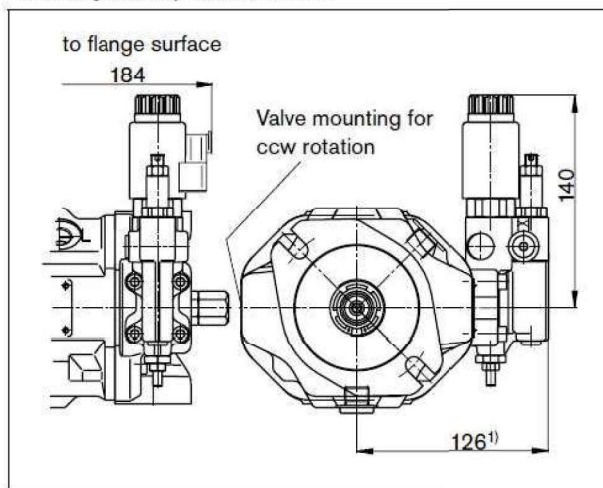

1) ER7.: 161 mm if using a sandwich plate pressure reducing valve.

■ Dimensions: Size 28

□ DFR/DFR1 - Pressure and flow control, hydraulic :

□ Clockwise rotation

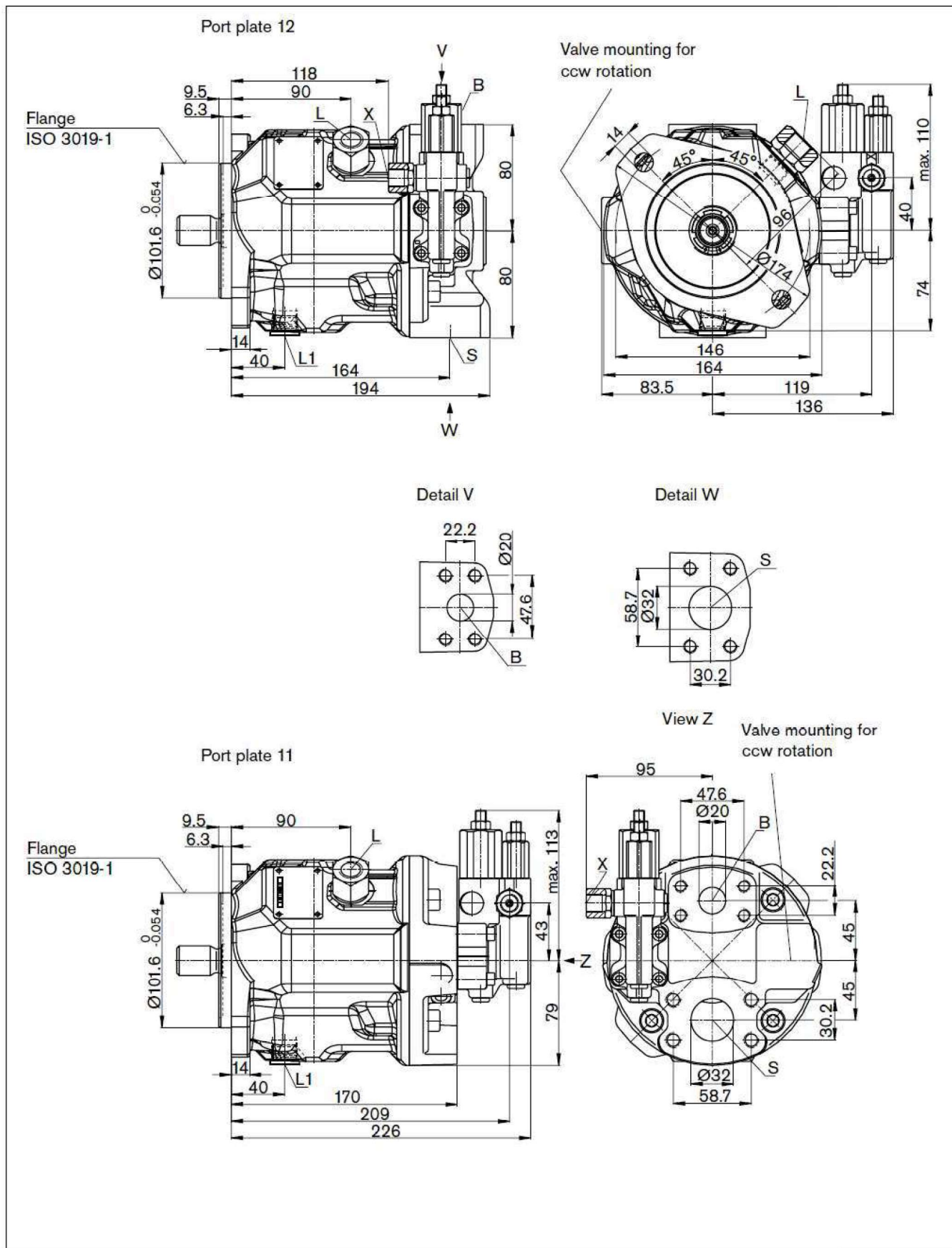

■ Dimensions: Size 28

□ Drive shaft:

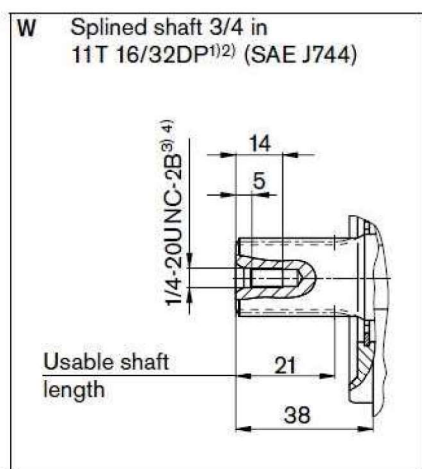
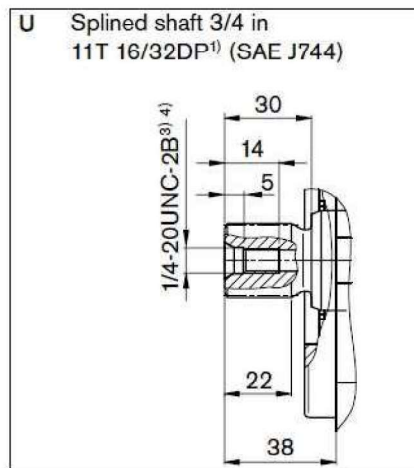
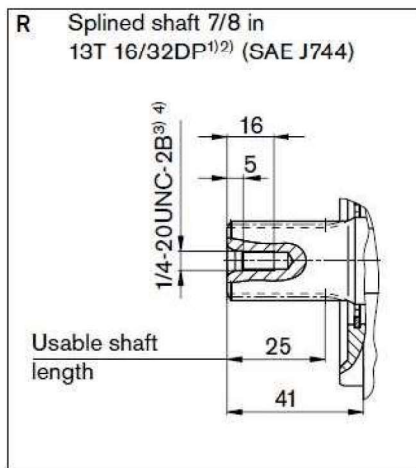
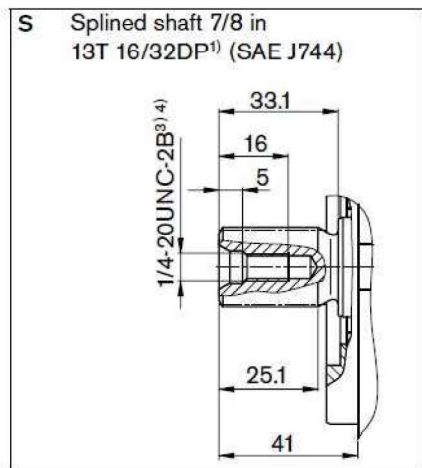

- 1) ANSI B92.1a, 30° pressure angle, flat root, side fit, tolerance class 5
- 2) Spline according to ANSI B92.1a, run out of spline is a deviation from standard.
- 3) Thread according to ASME B1.1
- 4) For the maximum tightening torques the general instructions on page 47 must be observed.

□ Ports:

Designation	Port for	Standard	Size	Maximum pressure (bar)	State
B	Service line fastening thread	SAE J518 DIN 13	3/4" M10 X 1.5 17 deep	350	O
S	Suction line fastening thread	SAE J518 DIN 13	1-1/4" M10 X 1.5 17 deep	10	O
L	Case drain fluid	DIN 3852	M18 X 1.5 12 deep	2	O
L ₁	Case drain fluid	DIN 3852	M18 X 1.5 12 deep	2	X
X	Pilot pressure	DIN 3852	M14 X 1.5 12 deep	350	O
X	Pilot pressure with DG-control	ISO 228	G 1/4" 12 deep	350	O

- O = Must be connected (plugged on delivery)
- X = Plugged (in normal operation)

■ Dimensions: Size 28

DG

Two-point control, directly operated, port plate 11

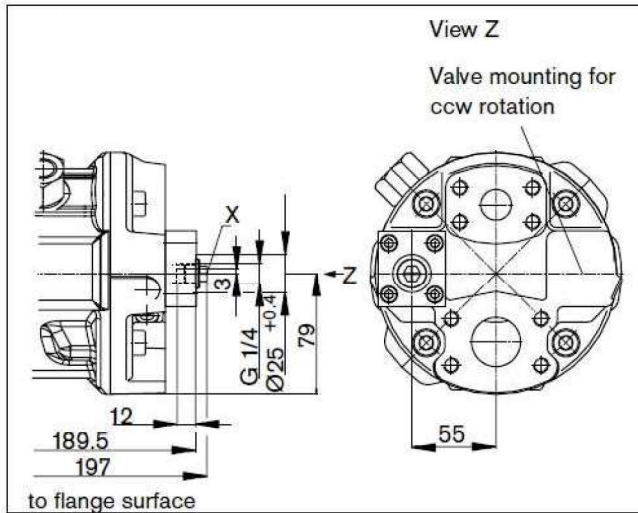

DG

Two-point control, directly operated, port plate 12

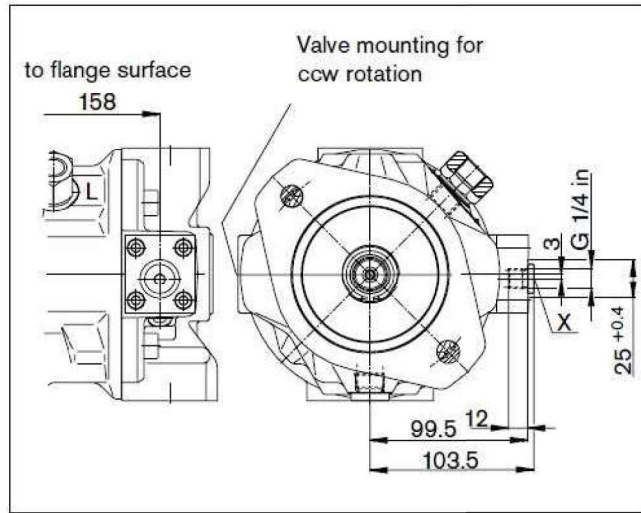

DR

Pressure control, port plate 11

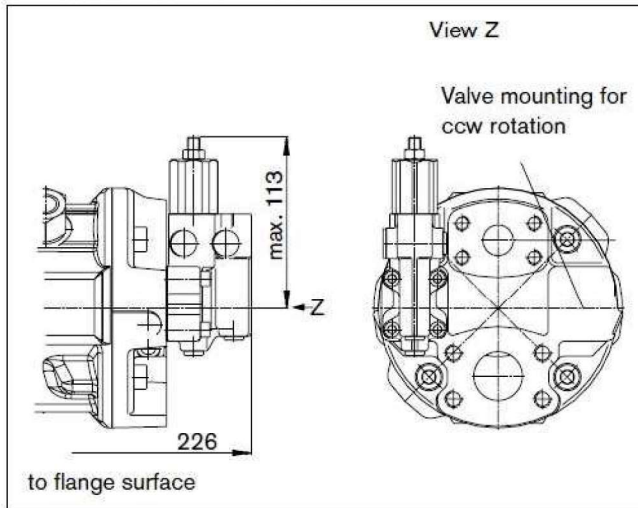

DR

Pressure control, port plate 12

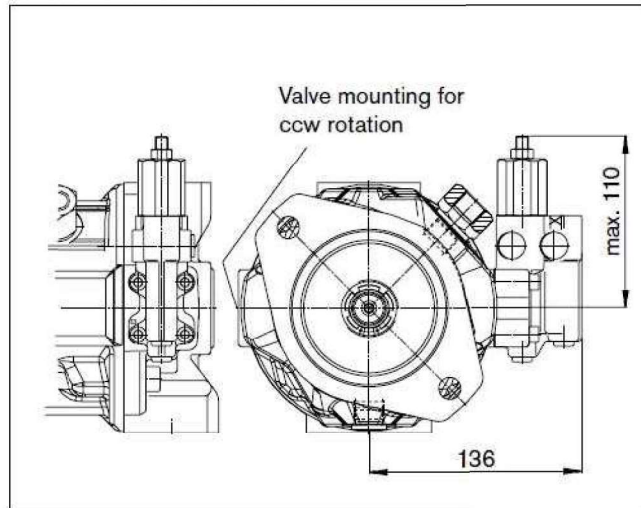

DRG

Pressure control, remotely operated, port plate 11

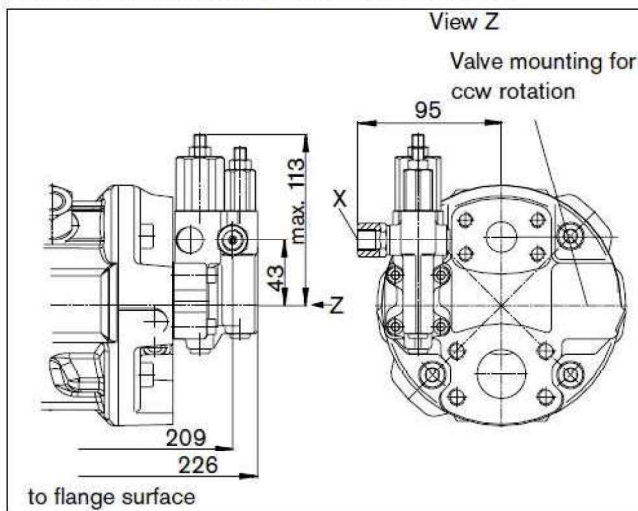

DRG

Pressure control, remotely operated, port plate 12

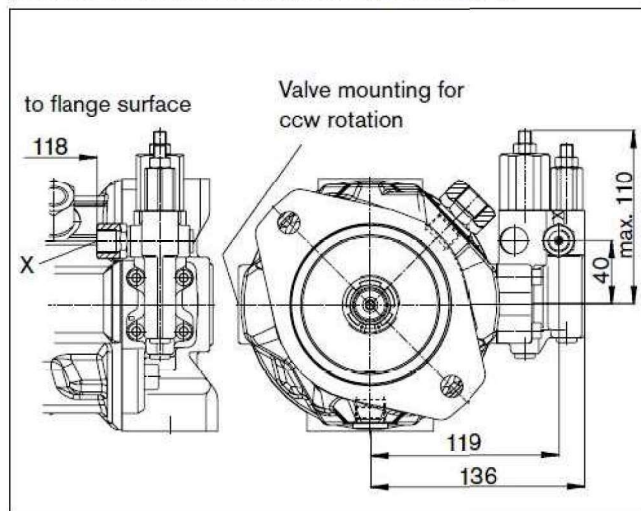

■ Dimensions: Size 28

DFLR

Pressure, flow and power control, port plate 11

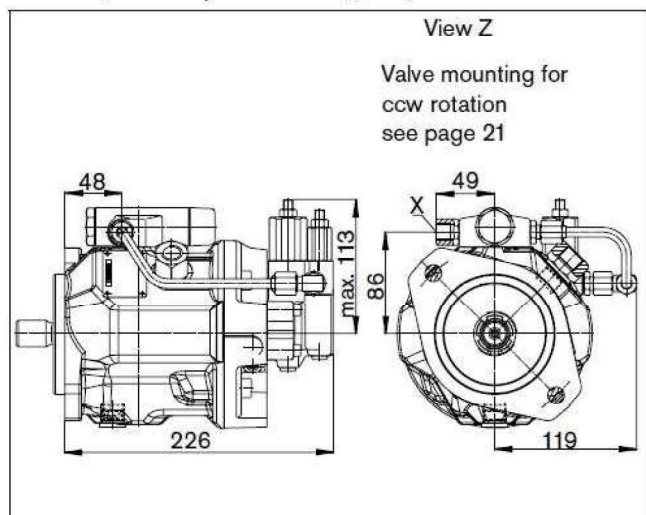

DFLR

Pressure, flow and power control, port plate 12

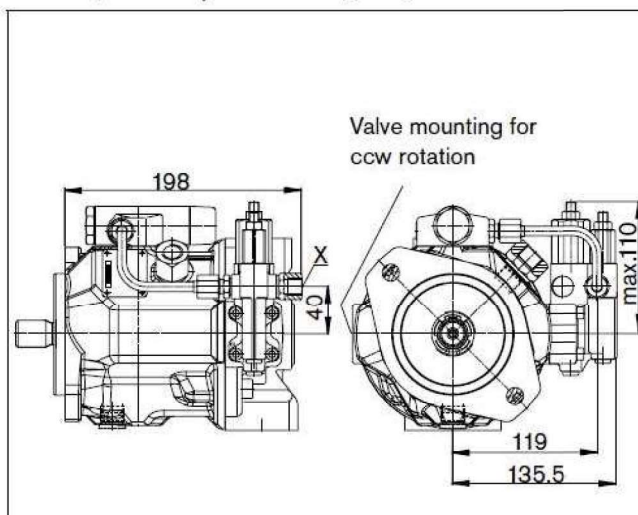

ED7. / ER7.

Electro-hydraulic pressure control, port plate 11

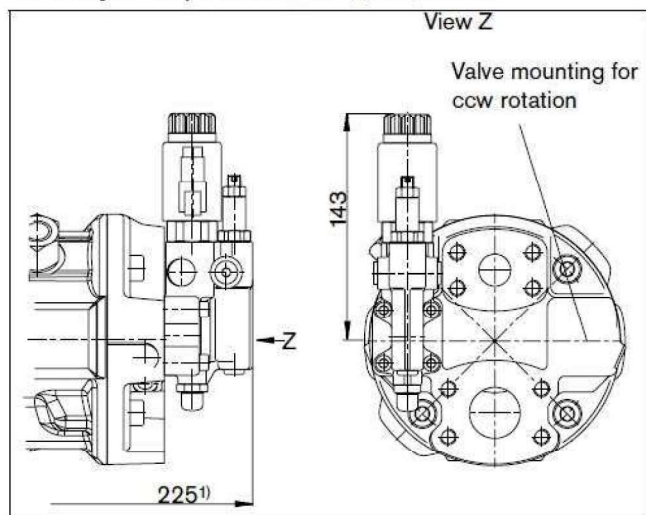

ED7. / ER7.

Electro-hydraulic pressure control, port plate 12

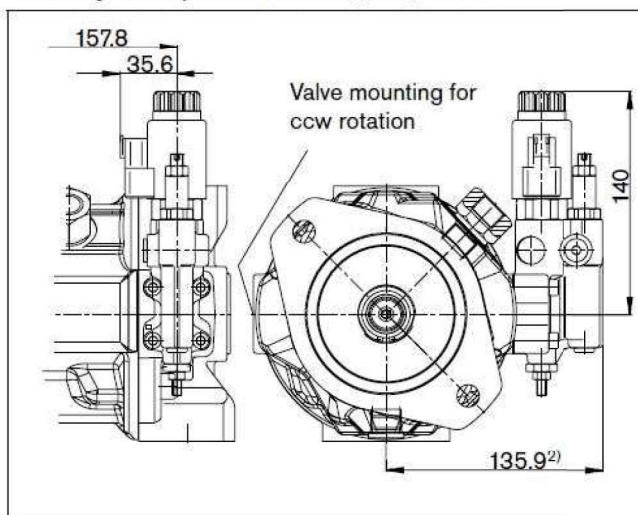

- 1) ER7. : 260 mm when using a sandwich plate pressure reducing valve.
- 2) ER7. : 170.9 mm when using a sandwich plate pressure reducing valve.

■ Dimensions: Size 45

□ DFR/DFR1 - Pressure and flow control, hydraulic:

□ Clockwise rotation

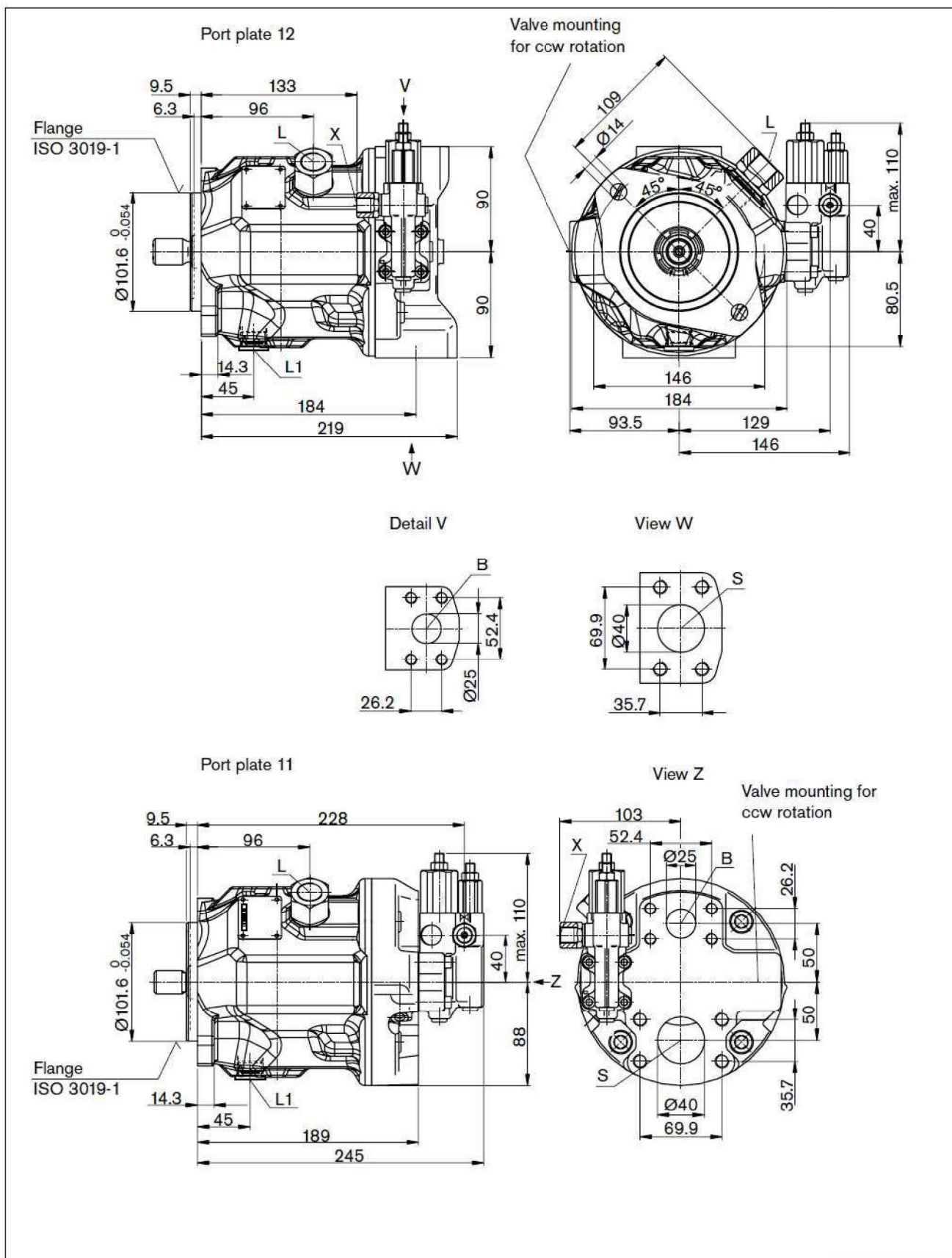

■ Dimensions: Size 45

□ Drive shaft:

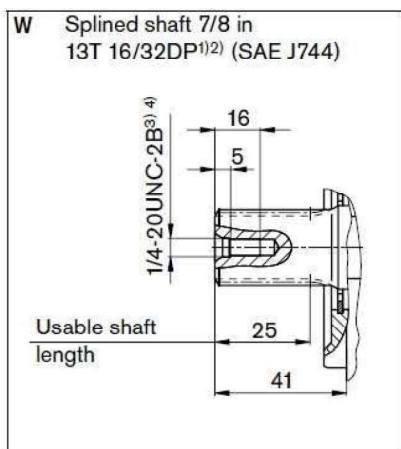
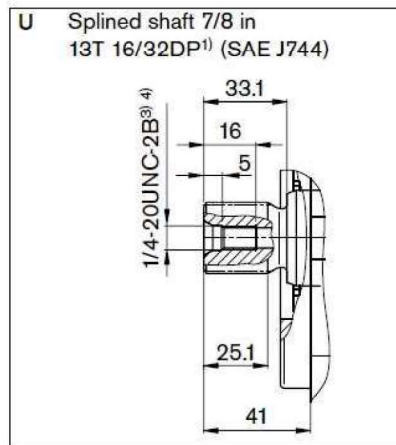
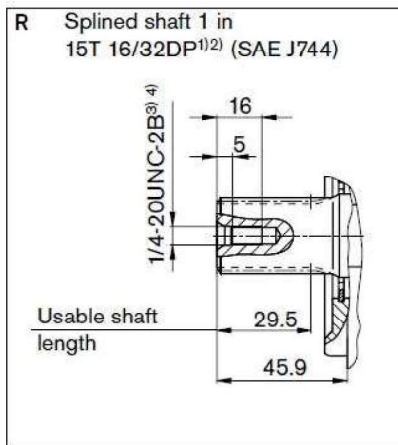
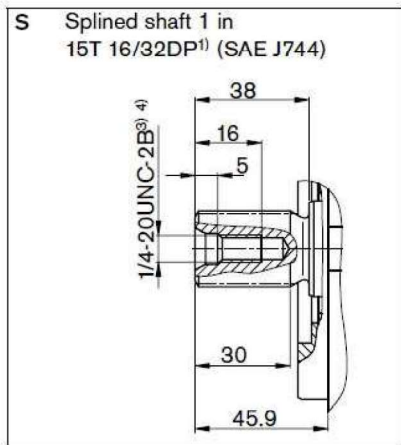

- 1) ANSI B92.1a, 30° pressure angle, flat root, side fit, tolerance class 5
- 2) Spline according to ANSI B92.1a, run out of spline is a deviation from standard.
- 3) Thread according to ASME B1.1
- 4) For the maximum tightening torques the general instructions on page 52 must be observed.

□ Ports:

Designation	Port for	Standard	Size	Maximum pressure (bar)	State
B	Service line fastening thread	SAE J518 DIN 13	1" M10 X 1.5 17 deep	350	O
S	Suction line fastening thread	SAE J518 DIN 13	1-1/2" M12 X 1.75 17 deep	10	O
L	Case drain fluid	DIN 3852	M22 X 1.5 12 deep	2	O
L ₁	Case drain fluid	DIN 3852	M22 X 1.5 12 deep	2	X
X	Pilot pressure	DIN 3852	M14 X 1.5 12 deep	350	O
X	Pilot pressure with DG-control	ISO 228	G 1/4" 12 deep	350	O

- O = Must be connected (plugged on delivery)
- X = Plugged (in normal operation)

■ Dimensions: Size 45

DG

Two-point control, directly operated, port plate 11

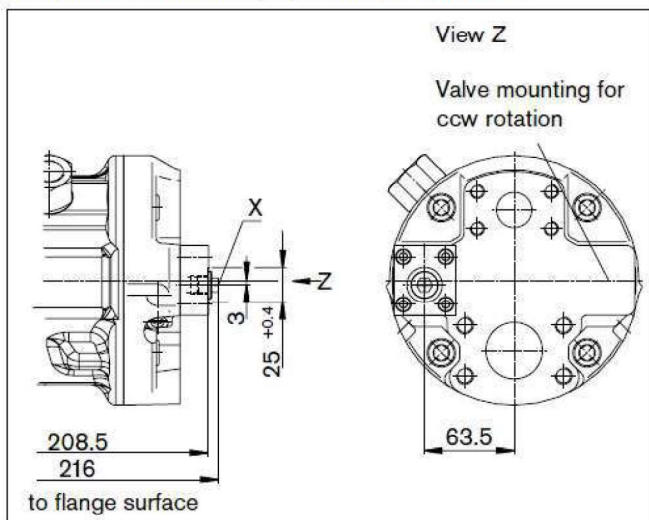

DG

Two-point control, directly operated, port plate 12

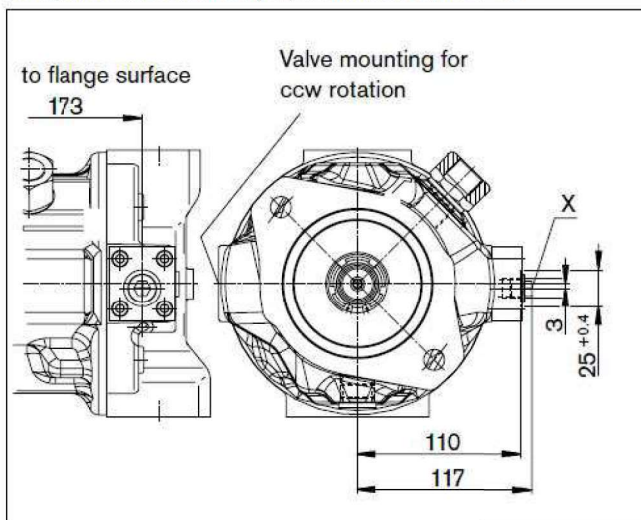

DR

Pressure control, port plate 11

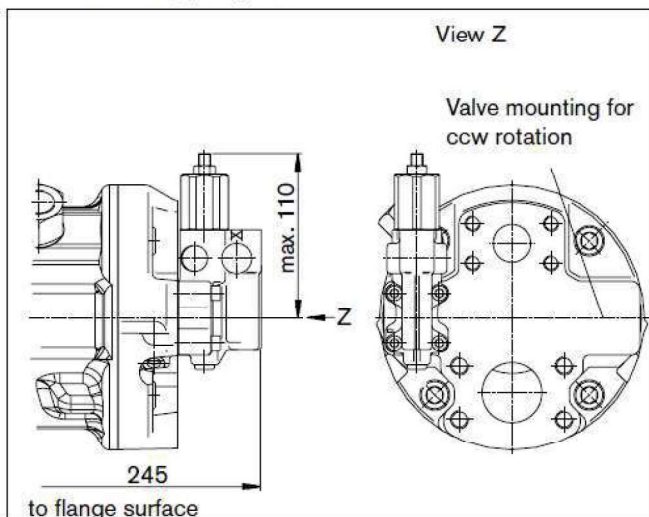

DR

Pressure control, port plate 12

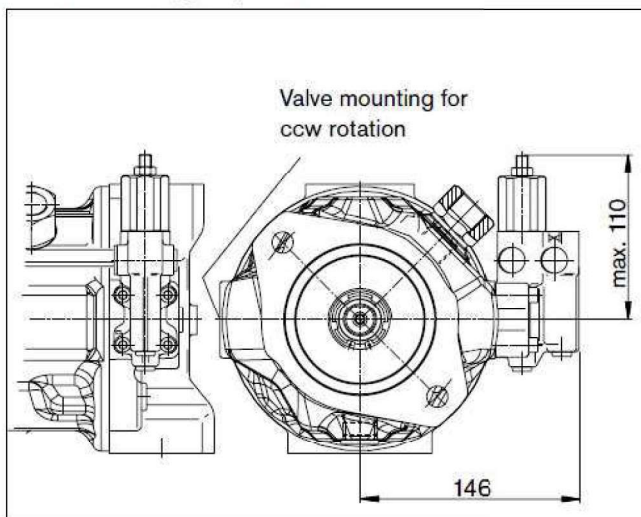

DRG

Pressure control, remotely operated, port plate 11

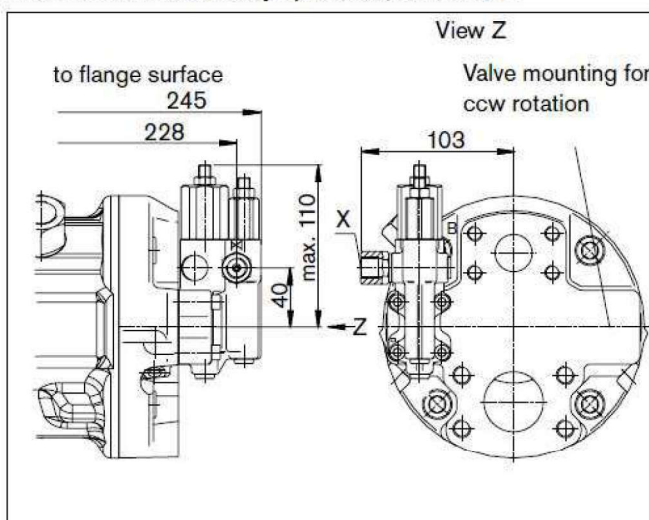

DRG

Pressure control, remotely operated, port plate 12

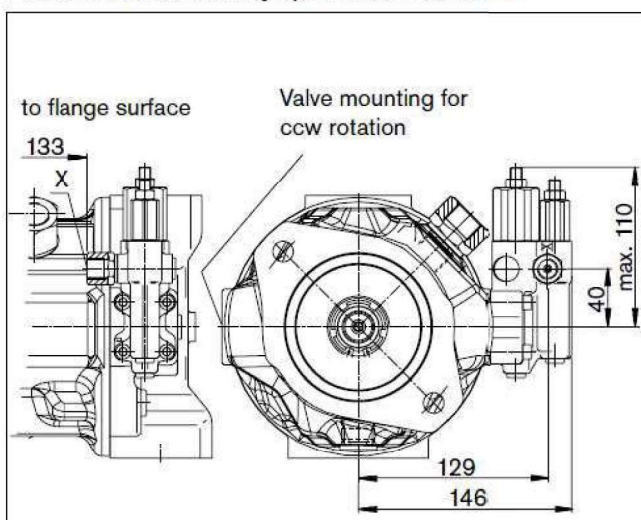

■ Dimensions: Size 45

DFLR

Pressure, flow and power control, port plate 11

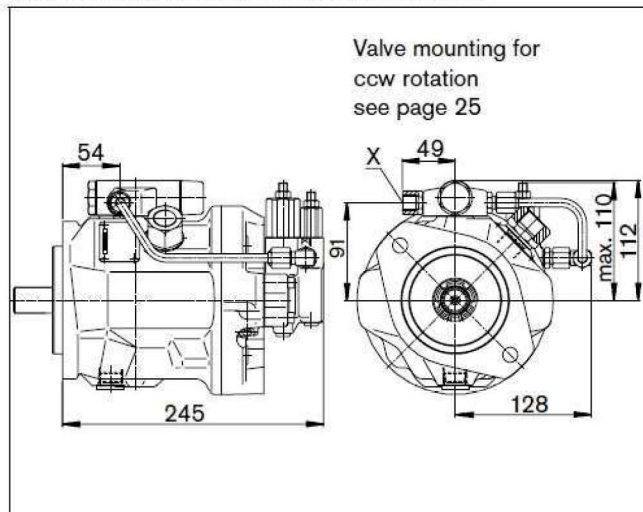

DFLR

Pressure, flow and power control, port plate 12

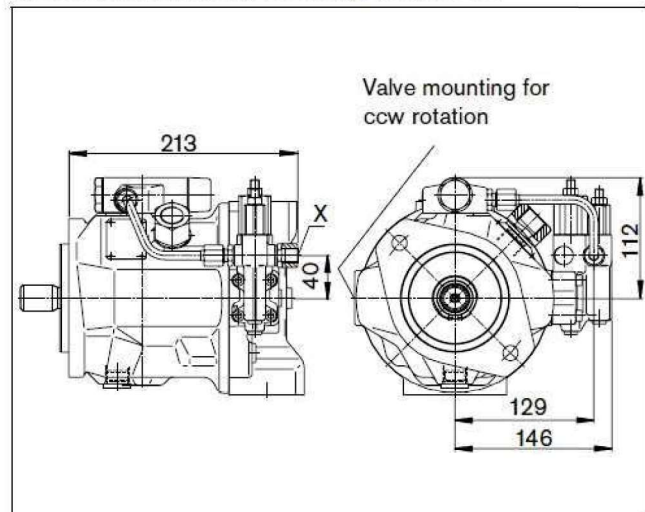

ED7. / ER7.

Electro-hydraulic pressure control, port plate 11

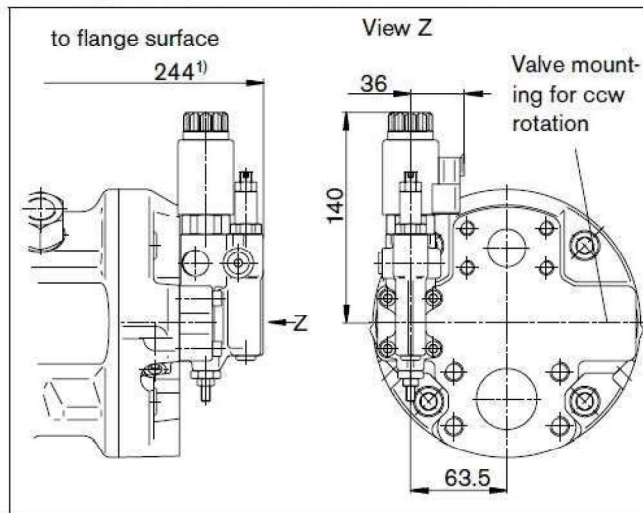

ED7. / ER7.

Electro-hydraulic pressure control, port plate 12

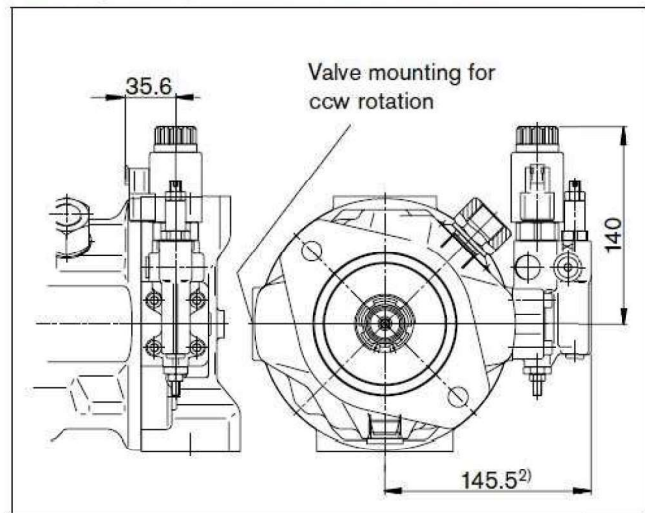

1) ER7.: 279 mm when using a sandwich plate pressure reducing valve

2) ER7.: 180.5 mm when using a sandwich plate pressure reducing valve.

■ Dimensions: Size71

□ DFR/DFR1– Pressure and flow control, hydraulic:

□ Clockwise rotation

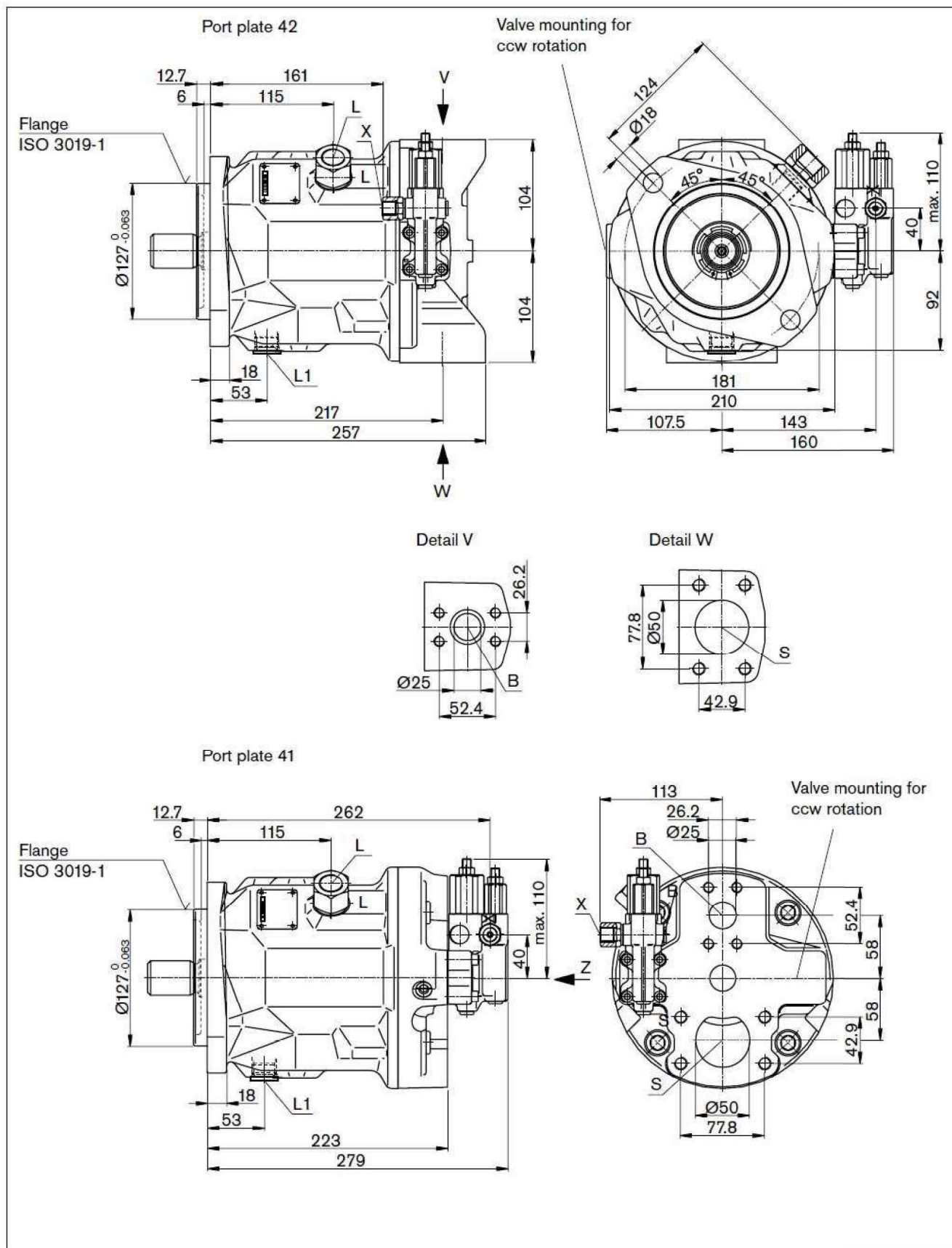

■ Dimensions: Size 71

□ Drive shaft:

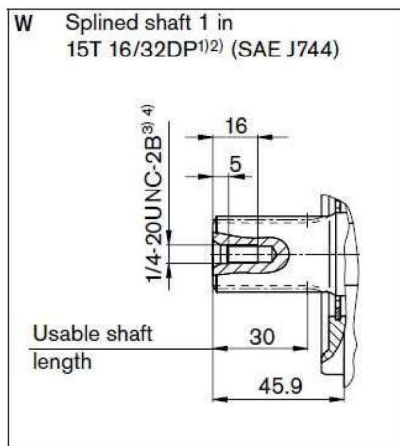
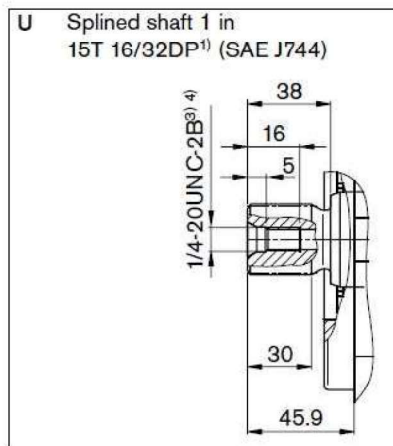
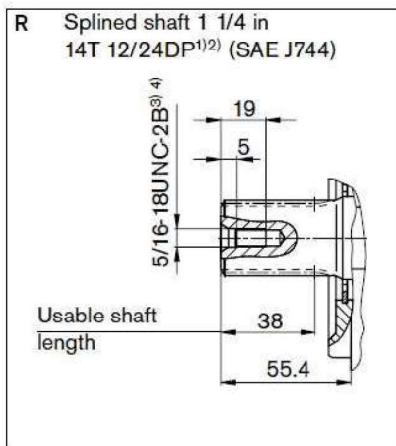
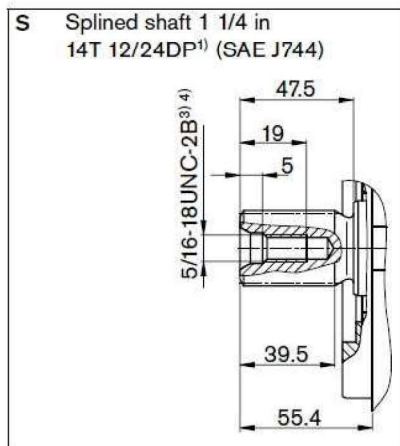

- 1) ANSI B92.1a, 30° pressure angle, flat root, side fit, tolerance class 5
- 2) Spline according to ANSI B92.1a, run out of spline is a deviation from standard.
- 3) Thread according to ASME B1.1
- 4) For the maximum tightening torques the general instructions on page 52 must be observed

□ Ports:

Designation	Port for	Standard	Size	Maximum pressure (bar)	State
B	Service line fastening thread	SAE J518 DIN 13	1" M10 X 1.5 17 deep	350	O
S	Suction line fastening thread	SAE J518 DIN 13	2" M12 X 1.75 20 deep	10	O
L	Case drain fluid	DIN 3852	M22 X 1.5 14 deep	2	O
L ₁	Case drain fluid	DIN 3852	M22 X 1.5 14 deep	2	X
X	Pilot pressure	DIN 3852	M14 X 1.5 12 deep	350	O
X	Pilot pressure with DG-control	ISO 228	G 1/4" 12 deep	350	O

- O = Must be connected (plugged on delivery)
- X = Plugged (in normal operation)

■ Dimensions: Size 71

DG

Two-point control, directly operated, port plate 41

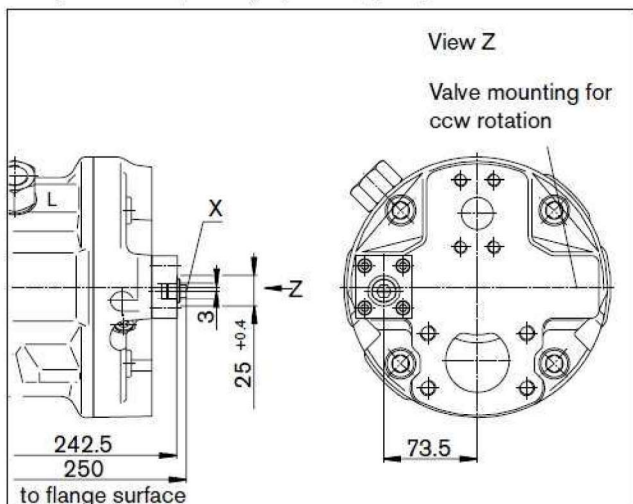

DG

Two-point control, directly operated, port plate 42

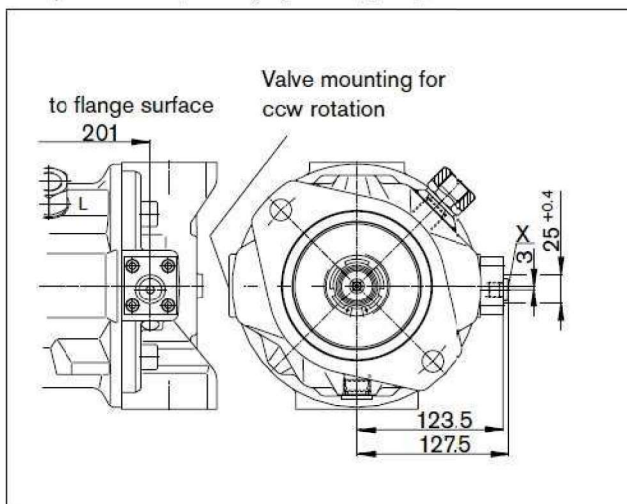

DR

Pressure control, port plate 41

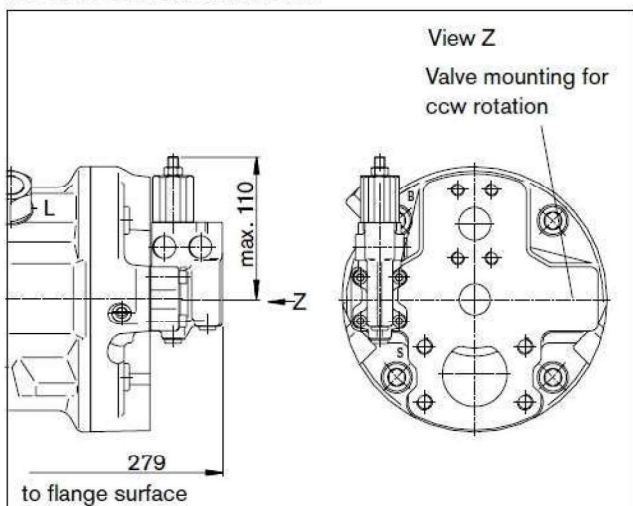

DR

Pressure control, port plate 42

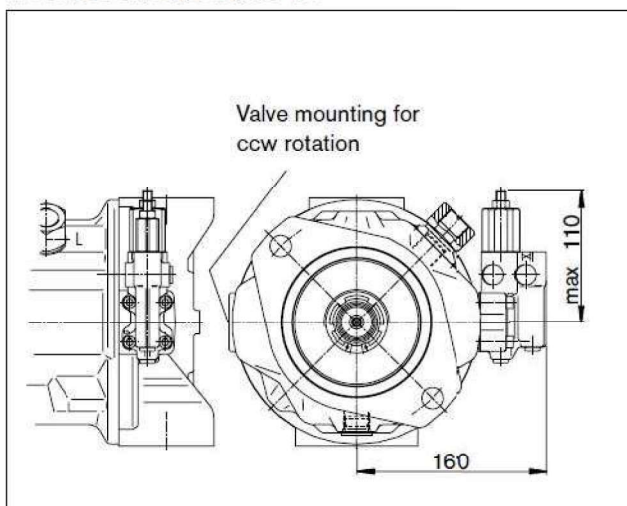

DRG

Pressure control, remotely operated, port plate 41

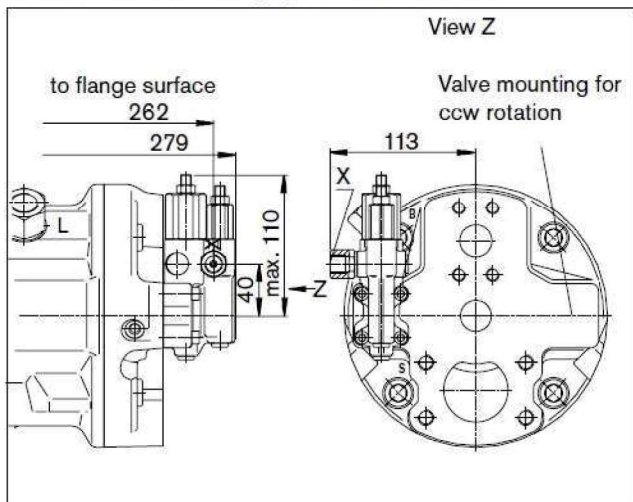

DRG

Pressure control, remotely operated, port plate 42

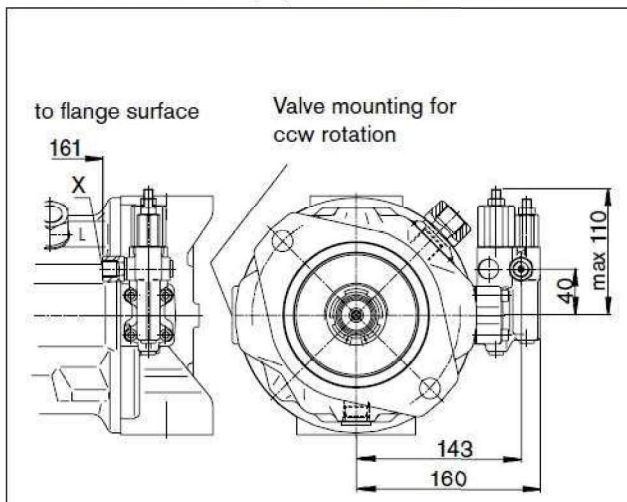

■ Dimensions: Size 71

DFLR

Pressure, flow and power control, port plate 41

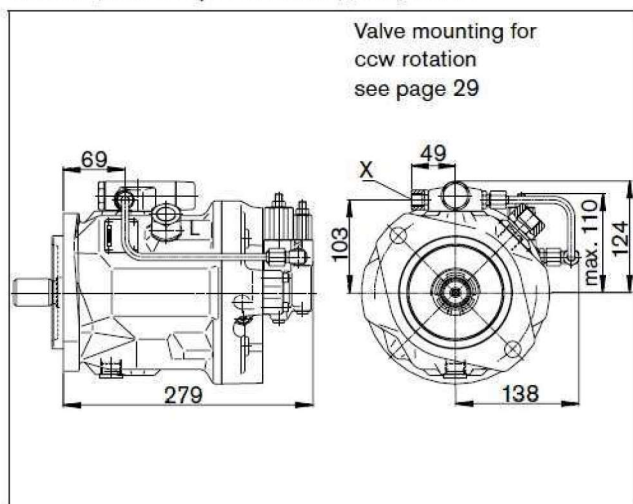

DFLR

Pressure, flow and power control, port plate 42

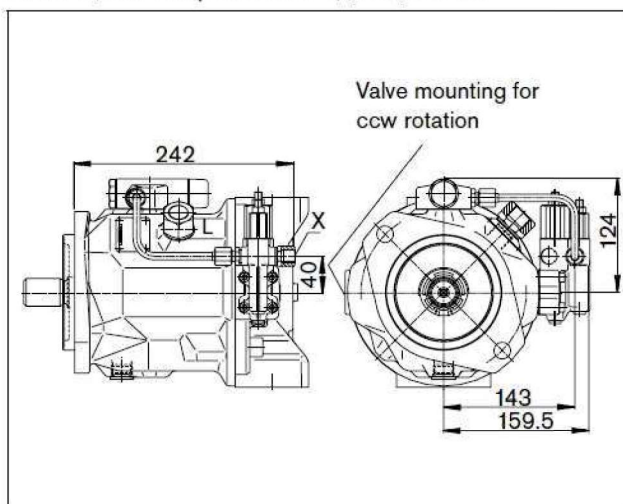

ED7. / ER7.

Electro-hydraulic pressure control, port plate 41

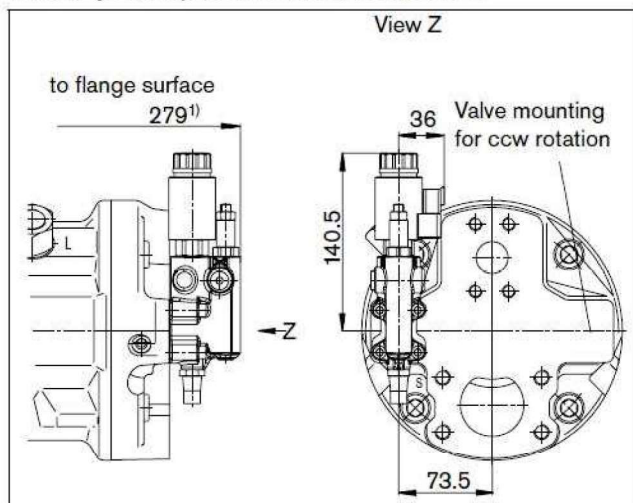

ED7. / ER7.

Electro-hydraulic pressure control, port plate 42

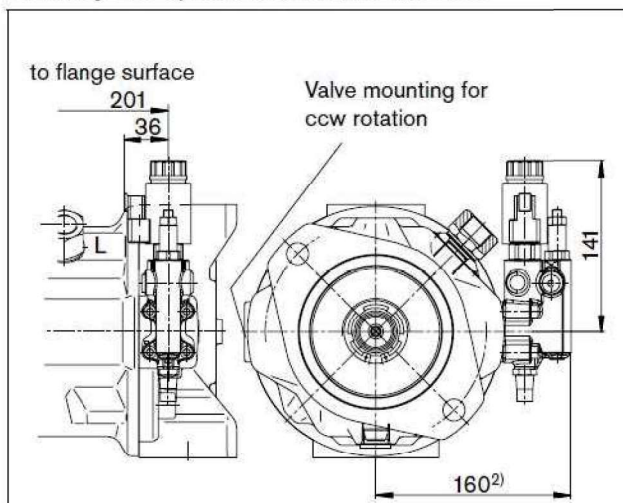

1) ER7.: 314 mm when using a sandwich plate pressure reducing valve.

2) ER7.: 195 mm when using a sandwich plate pressure reducing valve.

■ Dimensions: Size 100

□ DFR/DFR1 – Pressure and flow control, hydraulic:

□ Clockwise rotation

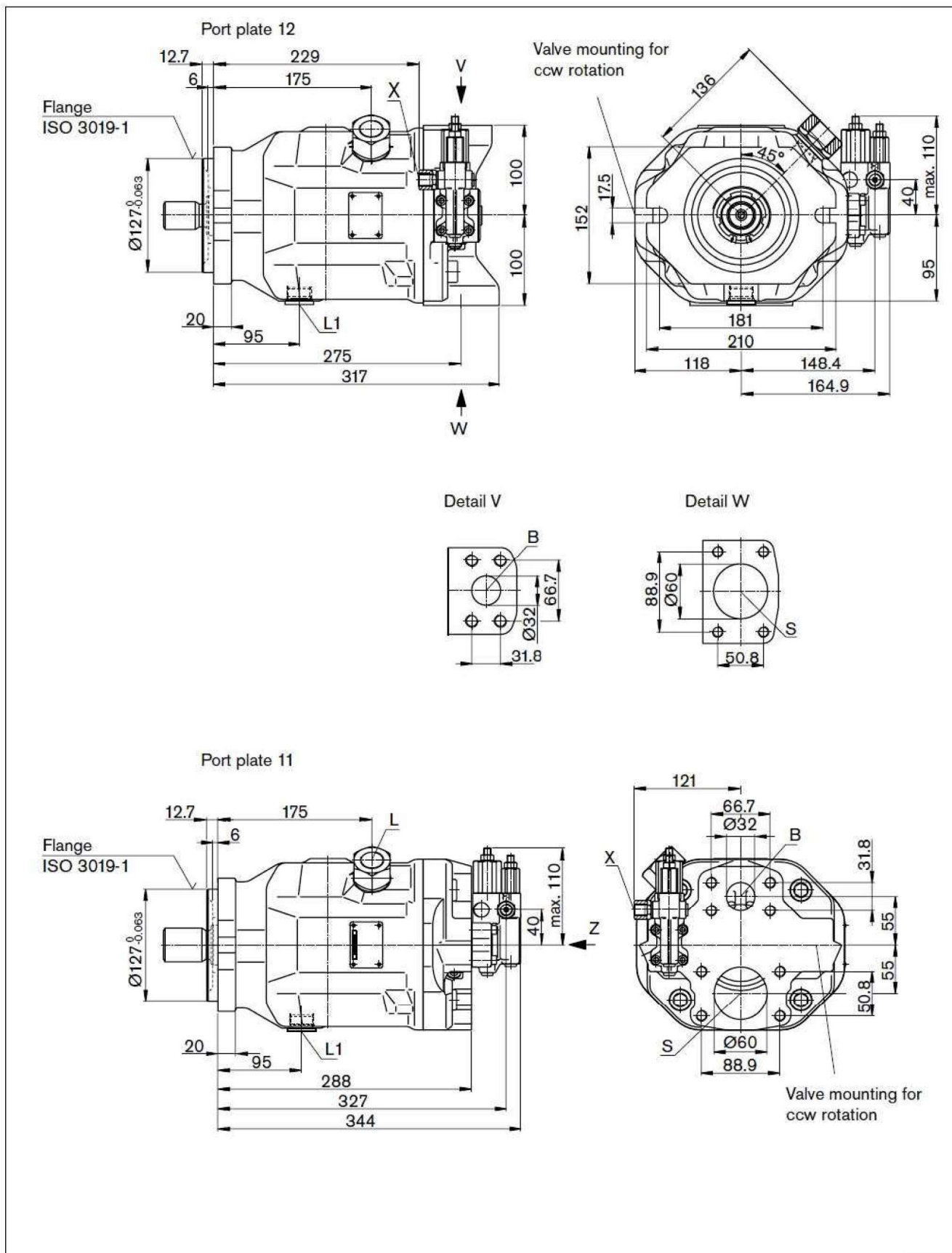

■ Dimensions: Size 100

□ Drive shaft:

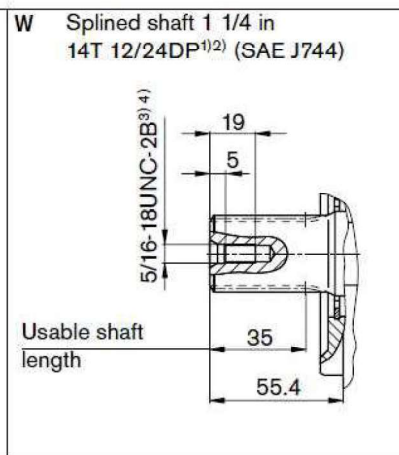
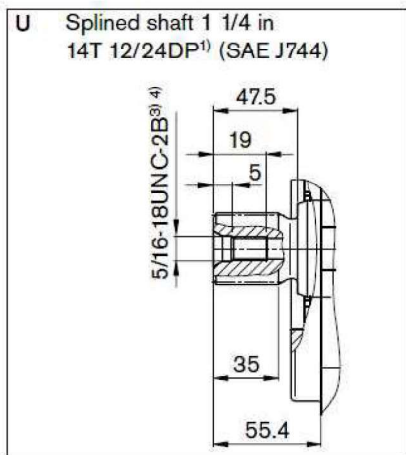
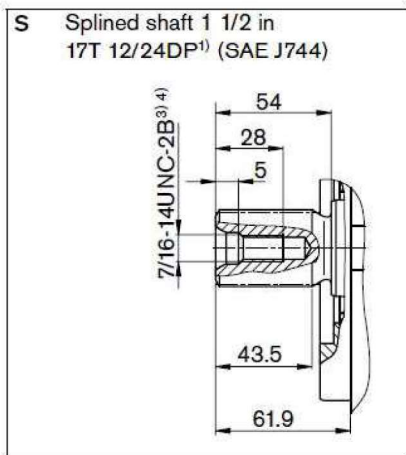

- 1) ANSI B92.1a, 30° pressure angle, flat root, side fit, tolerance class 5
- 2) Spline according to ANSI B92.1a, run out of spline is a deviation from standard.
- 3) Thread according to ASME B1.1
- 4) For the maximum tightening torques the general instructions on page 52 must be observed.

□ Ports:

Designation	Port for	Standard	Size	Maximum pressure (bar)	State
B	Service line fastening thread	SAE J518 DIN 13	1-1/4" M14 X 2 19 deep	350	O
S	Suction line fastening thread	SAE J518 DIN 13	2-1/2" M12 X 1.75 17 deep	10	O
L	Case drain fluid	DIN 3852	M27 X 2 16 deep	2	O
L ₁	Case drain fluid	DIN 3852	M27 X 2 16 deep	2	X
X	Pilot pressure	DIN 3852	M14 X 1.5 12 deep	350	O
X	Pilot pressure with DG-control	ISO 228	G 1/4" 12 deep	350	O

- O = Must be connected (plugged on delivery)
- X = Plugged (in normal operation)

■ Dimensions: Size 100

DG

Two-point control, directly operated, port plate 11

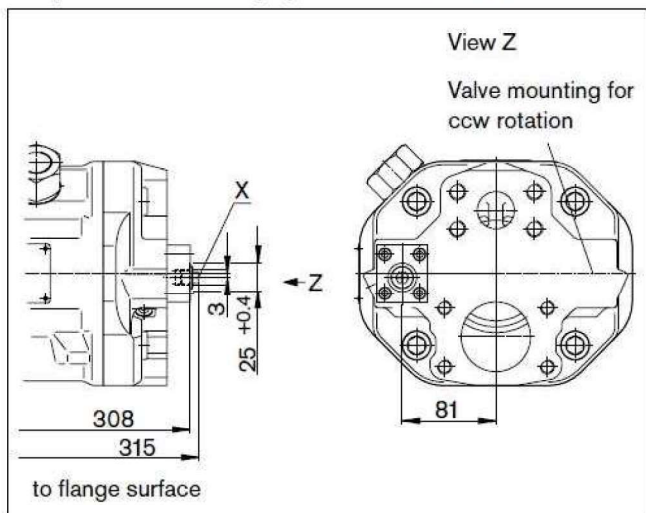

DG

Two-point control, directly operated, port plate 12

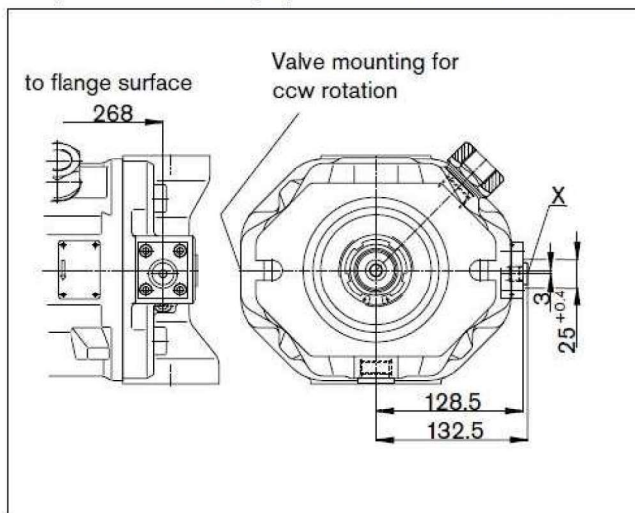

DR

Pressure control, port plate 11

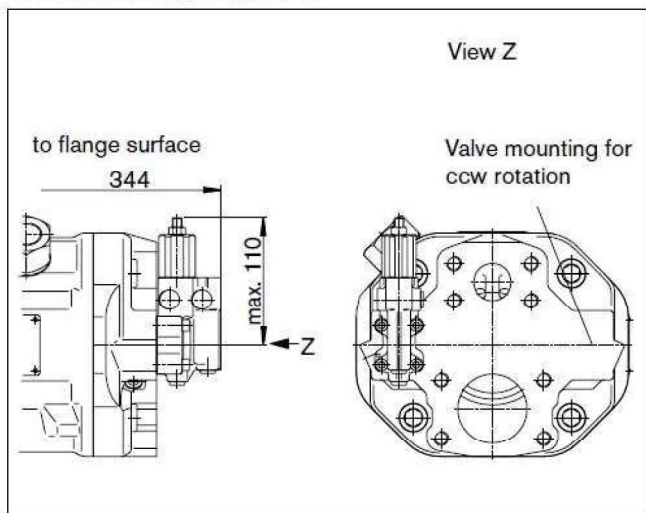

DR

Pressure control, port plate 12

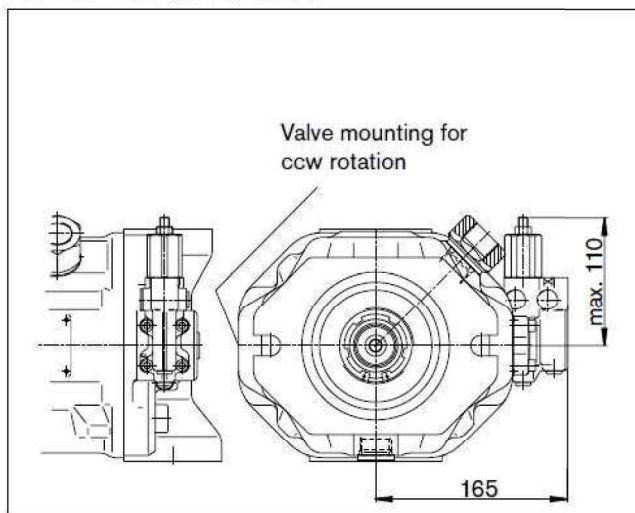

DRG

Pressure control, remotely operated, port plate 11

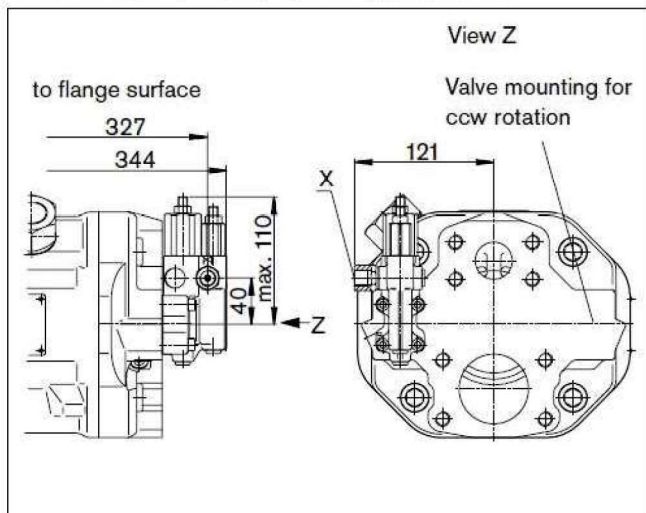

DRG

Pressure control, remotely operated, port plate 12

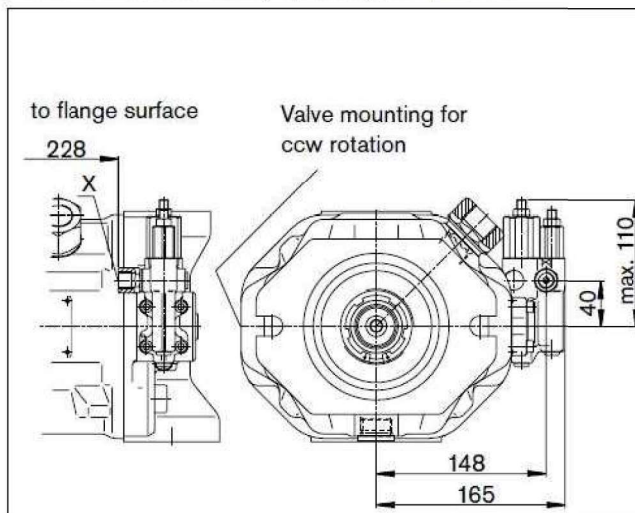

■ Dimensions: Size100

DFLR

Pressure, flow and power control, port plate 11

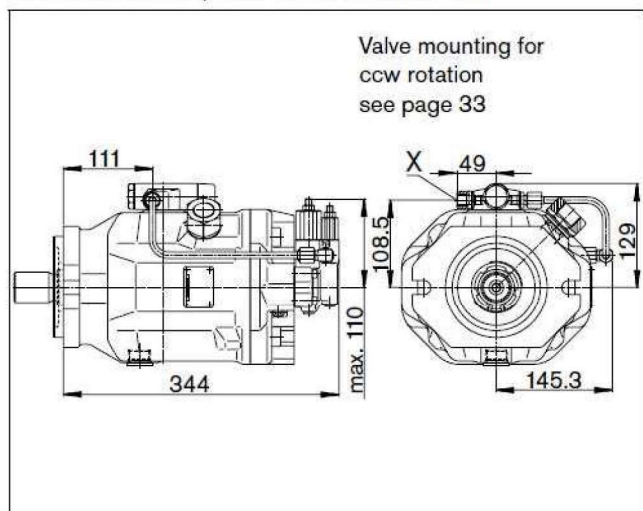

DFLR

Pressure, flow and power control, port plate 12

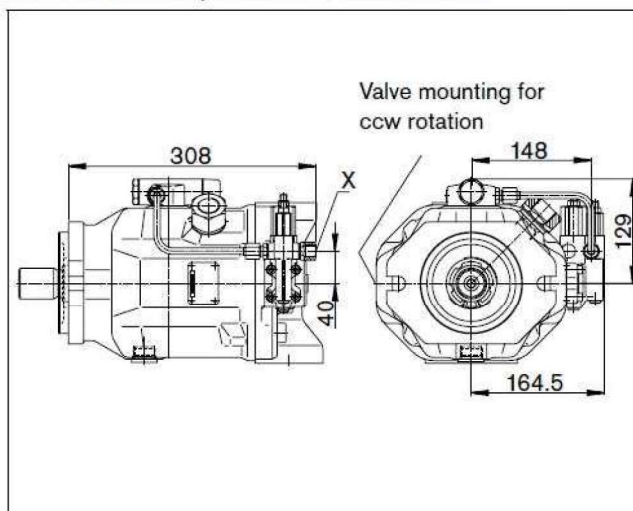

ED7./ER7.

Electro-hydraulic pressure control, port plate 11

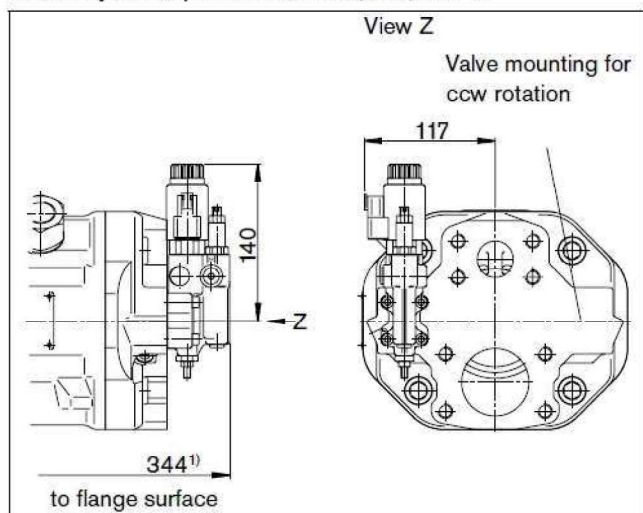

ED7./ER7.

Electro-hydraulic pressure control, port plate 12

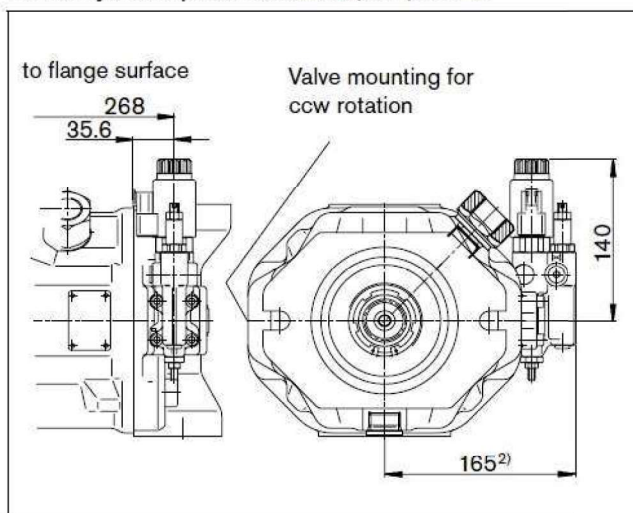

1) ER7. : 379 mm when using a sandwich plate pressure reducing valve.

2) ER7. : 200 mm when using a sandwich plate pressure reducing valve.

■ Dimensions: Size140

□ DFR/DFR1– Pressure and flow control, hydraulic:

□ Clockwise rotation, mounting flange D

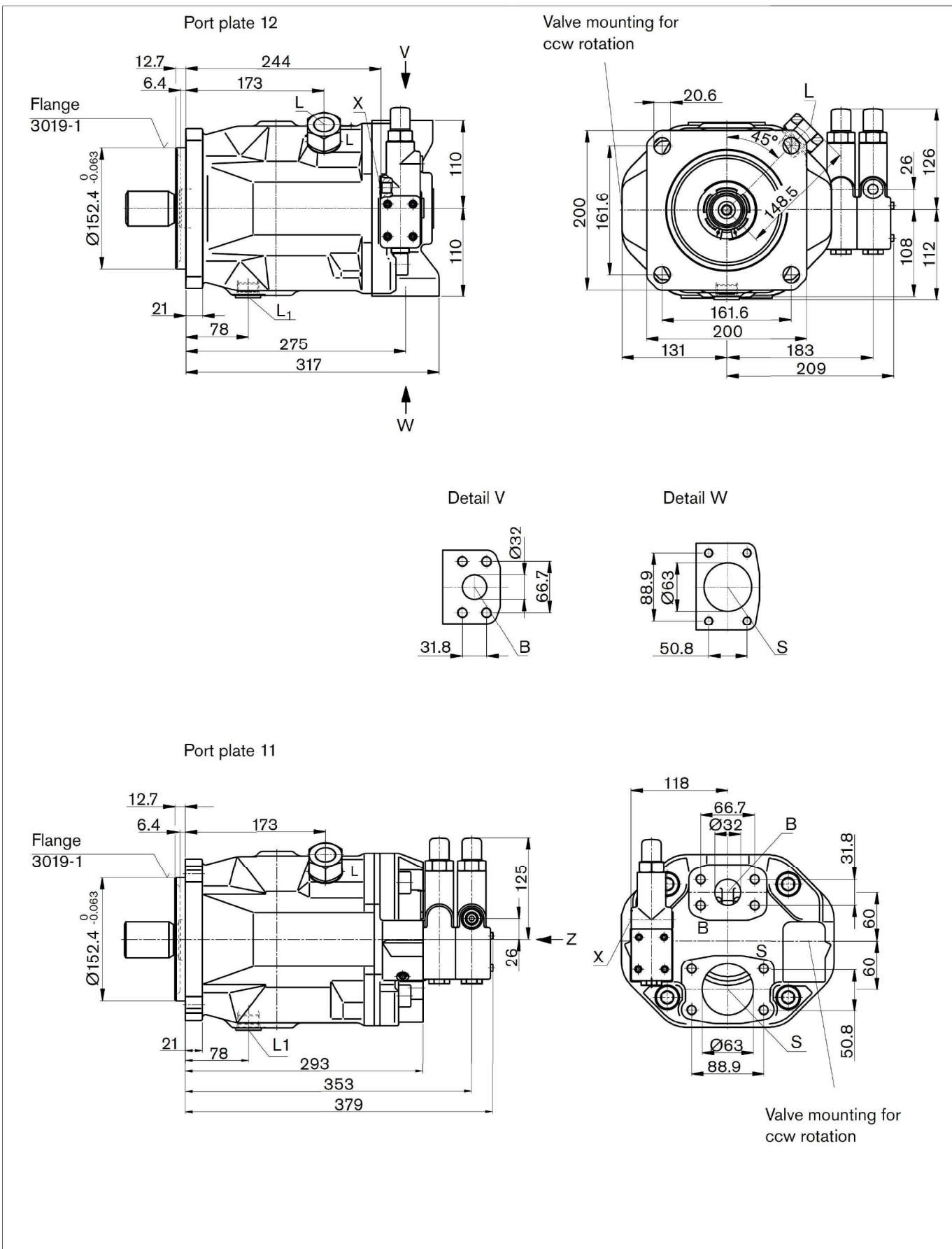

■ Dimensions: Size 140

- DFR/DFR1– Pressure and flow control, hydraulic:
- Clockwise rotation, mounting flange C

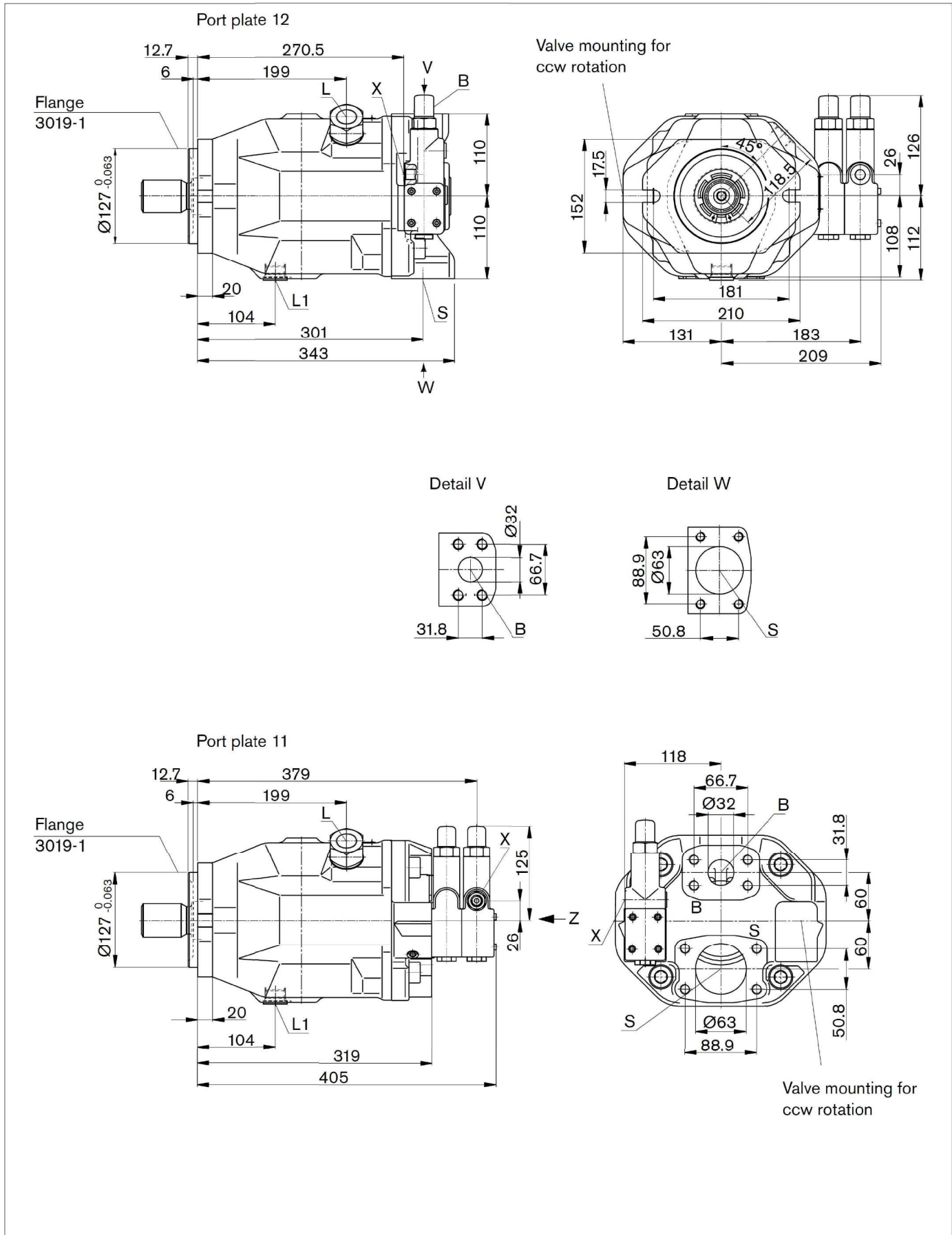

■ Dimension: Size 140

□ Drive shaft:

S Splined shaft 1 3/4 in
13T 8/16DP¹⁾ (SAE J744)

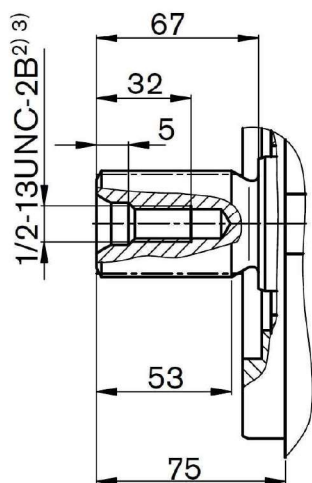

1) ANSI B92.1a, 30° pressure angle, flat root, side fit, tolerance class 5

2) Thread according to ASME B1.1

3) For the maximum tightening torques the general instructions on page 52 must be observed.

□ Ports:

Designation	Port for	Standard	Size	Maximum pressure (bar)	State
B	Service line fastening thread	SAE J518 DIN 13	1-1/4" M14 X 2 19 deep	350	O
S	Suction line fastening thread	SAE J518 DIN 13	2-1/2" M12 X 1.75 17 deep	10	O
L	Case drain fluid	DIN 3852	M27 X 2 16 deep	2	O
L ₁	Case drain fluid	DIN 3852	M27 X 2 16 deep	2	X
X	Pilot pressure	DIN 3852	M14 X 1.5 12 deep	350	O
X	Pilot pressure with DG-control	DIN 3852	M14 X 1.5 12 deep	350	O
M _H	Gauge port, high pressure	DIN 3852	M14 X 1.5 12 deep	350	X

□ O = Must be connected (plugged on delivery)

□ X = Plugged (in normal operation)

■ Dimensions: Size 140

DG

Two-point control, directly operated, **port plate 11**

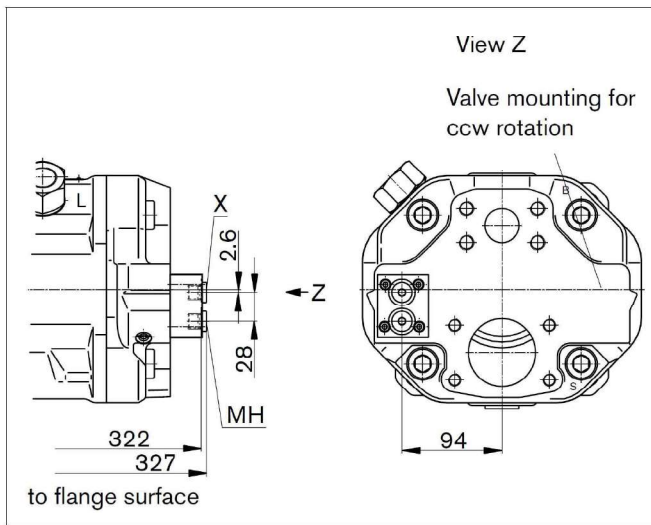

DG

Two-point control, directly operated, **port plate 12**

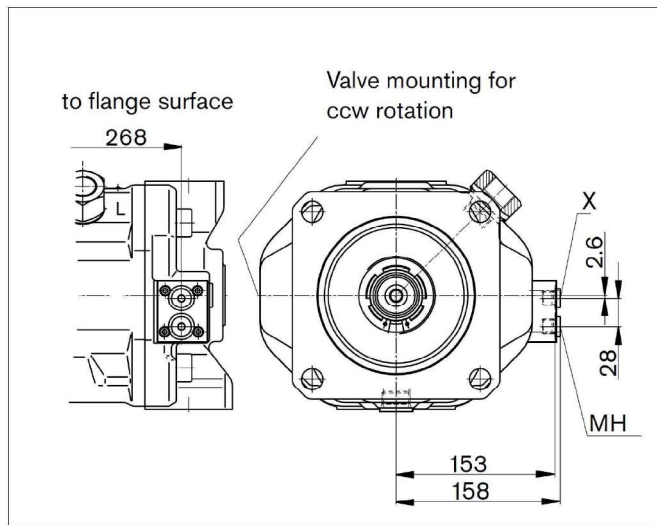

DR

Pressure control, **port plate 11**

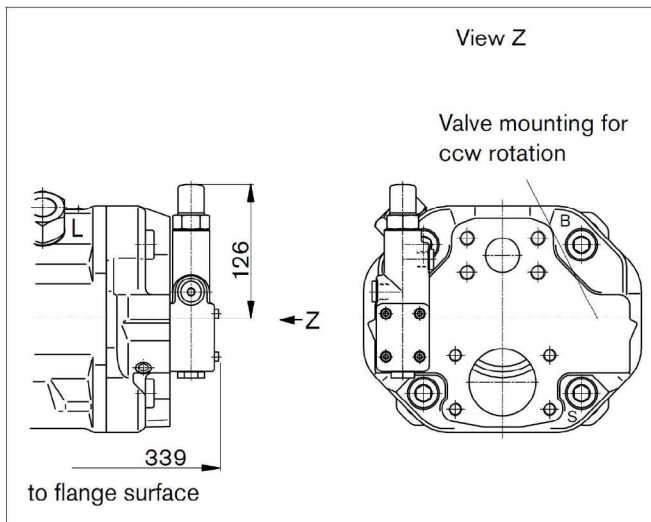

DR

Pressure control, **port plate 12**

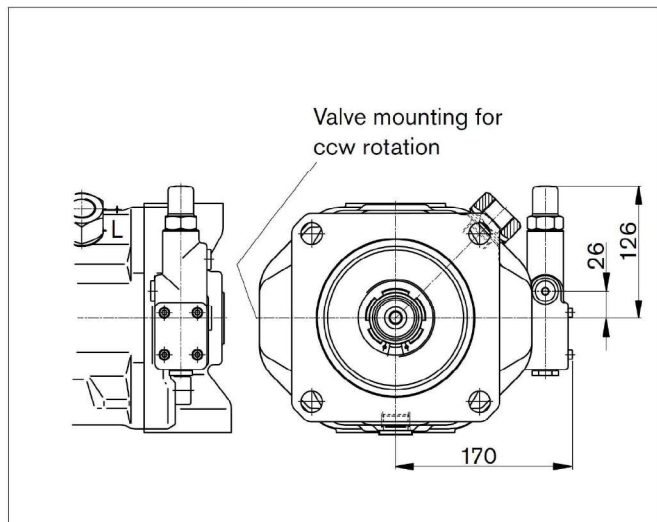

DRG

Pressure control, remotely operated, **port plate 11**

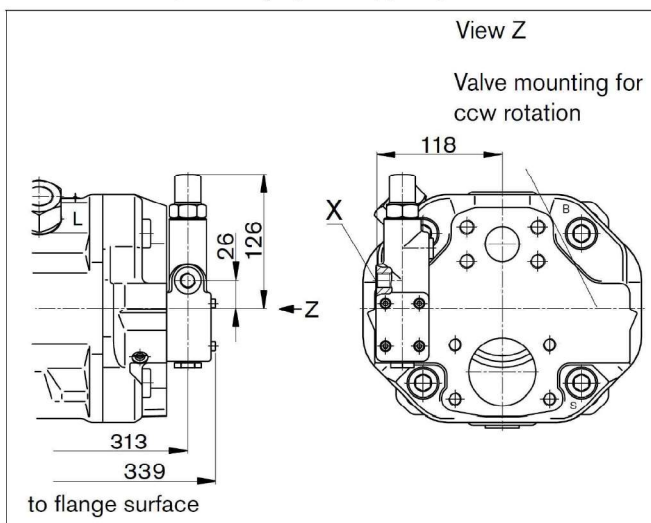

DRG

Pressure control, remotely operated, **port plate 12**

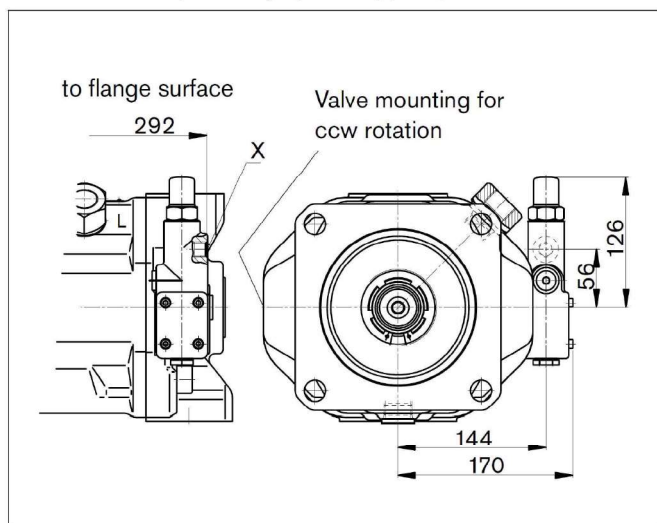

Dimensions: Size 140

DFLR

Pressure, flow and power control, **port plate 11**

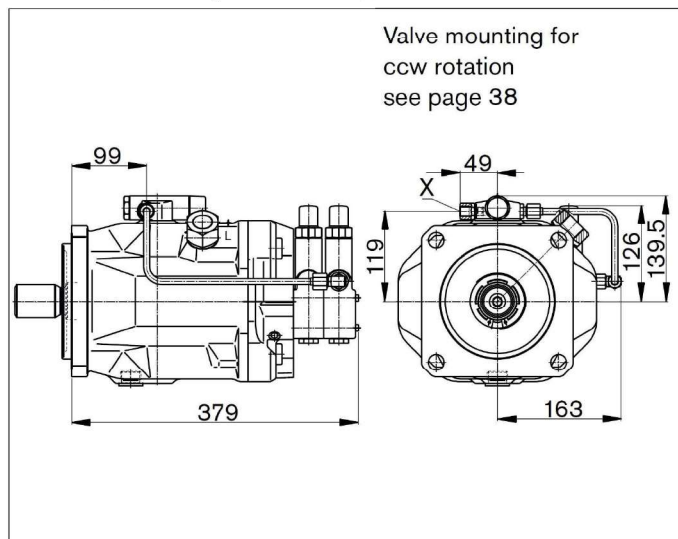

DFLR

Pressure, flow and power control, **port plate 12**

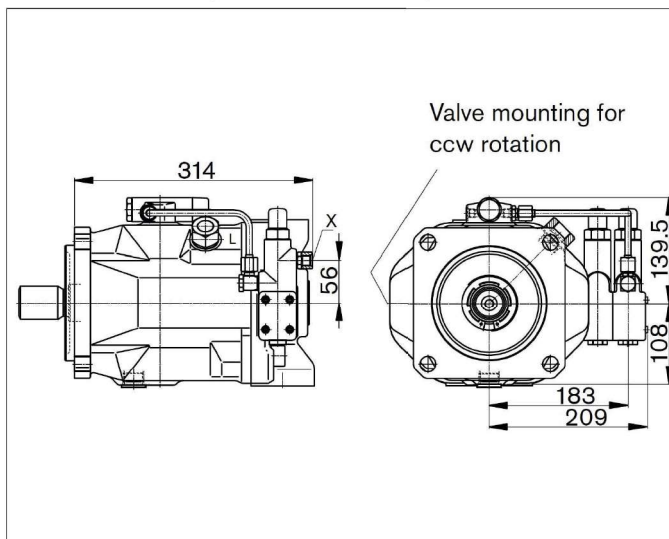

ED7. / ER7.

Electro-hydraulic pressure control, **port plate 11**

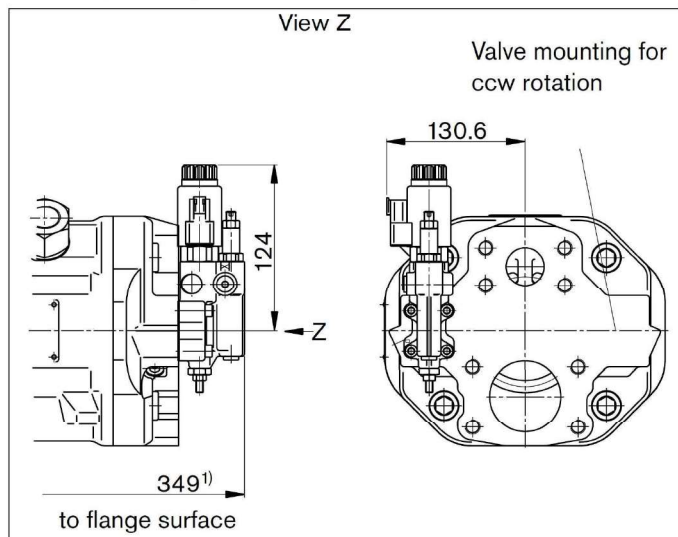

ED7. / ER7.

Electro-hydraulic pressure control, **port plate 12**

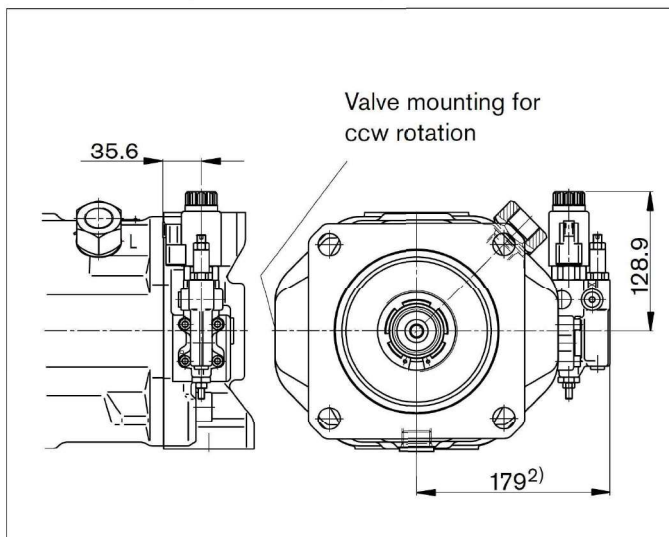

1) ER7.: 384 mm when using a sandwich plate pressure reducing valve.

2) ER7.: 214 mm when using a sandwich plate pressure reducing valve.

■ Dimensions...though drive K01:

□ Flange ISO 3019-2 (SAE J744-82-2 A)

□ Coupling for splined shaft according to ANSI B92.1a-1996 5/8" 9T 16/32 DP¹⁾(SAE J744-16-4 A)

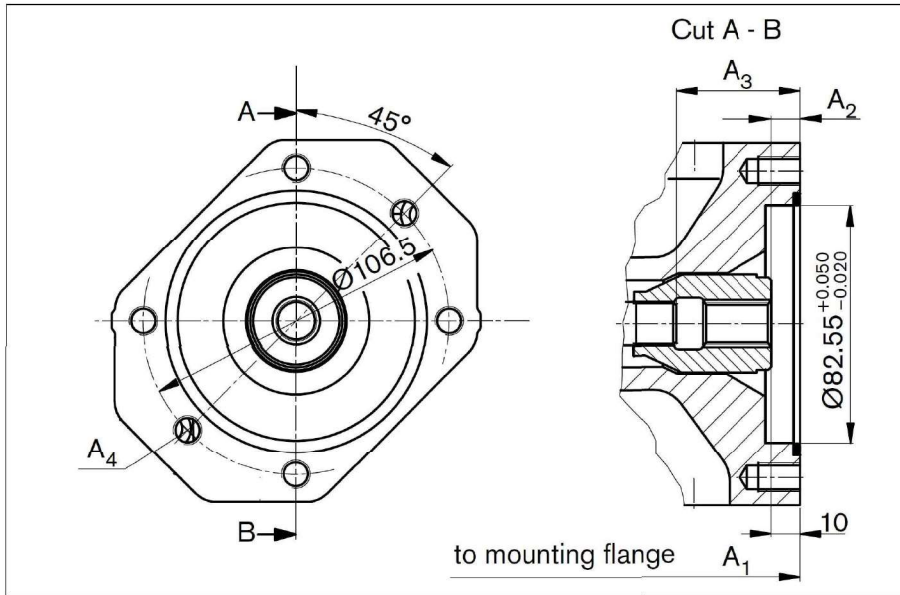

NG	A ₁	A ₂	A ₃	A ₄ ²⁾
18	182	10	43.3	M10 x 1.5, 14.5 deep
28	204	10	33.7	M10 x 1.5, 16 deep
45	229	10.7	53.4	M10 x 1.5, 16 deep
71	267	11.8	61.3	M10 x 1.5, 20 deep
100	338	10.5	65	M10 x 1.5, 16 deep
140	350	10.8	77.3	M10 x 1.5, 16 deep

1) 30° pressure angle, flat root, side fit, tolerance class 5

2) Thread according to DIN 13, observe the general instructions on page 47 for the maximum tightening torques.

■ Dimensions...though drive K52:

□ Flange ISO 3019-2 (SAE J744-82-2 A)

□ Coupling for splined shaft according to ANSI B92.1a-1996 3/4" 11T 16/32 DP¹⁾(SAE J744-19-4 A-B)

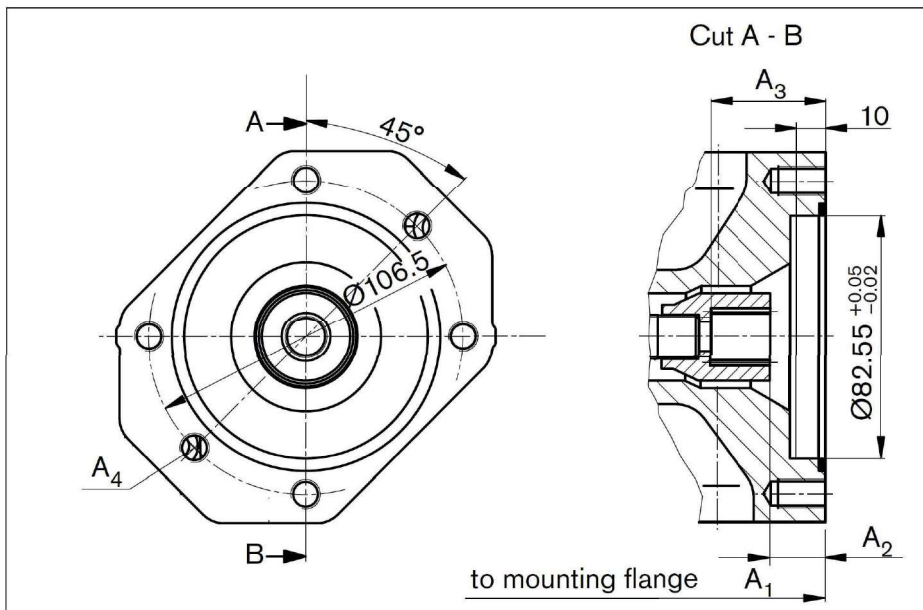

NG	A ₁	A ₂	A ₃	A ₄ ²⁾
18	182	18.8	38.7	M10 x 1.5, 14.5 deep
28	204	18.8	38.7	M10 x 1.5, 16 deep
45	229	18.9	38.7	M10 x 1.5, 16 deep
71	267	21.3	41.4	M10 x 1.5, 20 deep
100	338	19	38.9	M10 x 1.5, 16 deep
140	350	18.9	38.6	M10 x 1.5, 16 deep

1) 30° pressure angle, flat root, side fit, tolerance class 5

2) Thread according to DIN 13, observe the general instructions on page 47 for the maximum tightening torques.

■ Dimensions...though drive K68:

□ Flange ISO 3019-2 (SAE J744-101-2 B)

□ Coupling for splined shaft according to ANSI B92.1a-1996 7/8" 13T 16/32 DP¹⁾ (SAE J744-22-4 B)

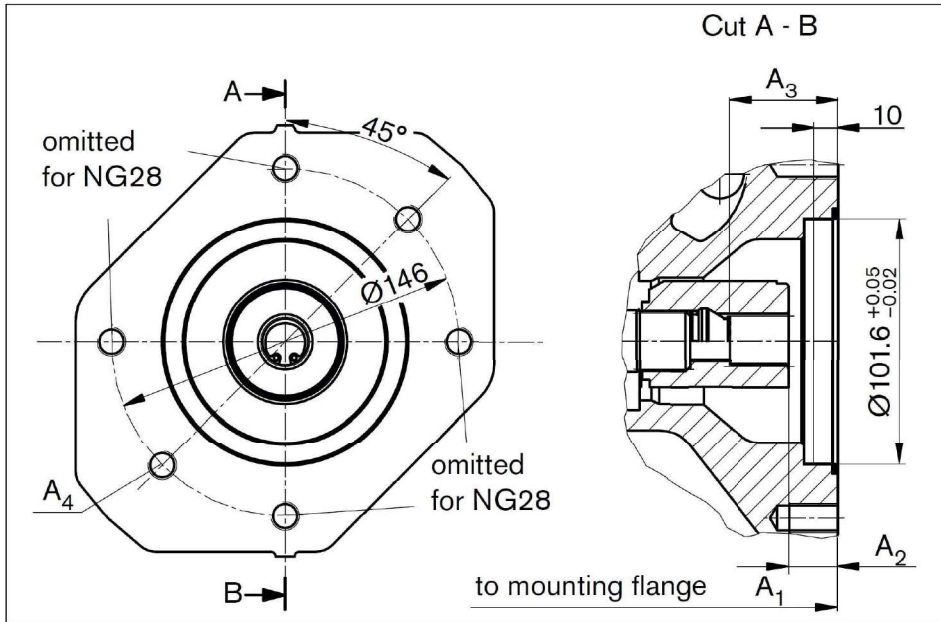

NG	A ₁	A ₂	A ₃	A ₄ ²⁾
28	204	17.8	41.7	M12 x 1.75, continuous
45	229	17.9	41.7	M12 x 1.75, 18 deep
71	267	20.3	44.1	M12 x 1.75, 20 deep
100	338	18	41.9	M12 x 1.75, 20 deep
140	350	17.8	41.6	M12 x 1.75, 20 deep

1) 30° pressure angle, flat root, side fit, tolerance class 5

2) Thread according to DIN 13, observe the general instructions on page 47 for the maximum tightening torques.

■ Dimensions...though drive K04:

□ Flange ISO 3019-2 (SAE J744-101-2 B)

□ Coupling for splined shaft according to ANSI B92.1a-1996 1" 15T 16/32 DP¹⁾ (SAE J744-25-4 B-B)

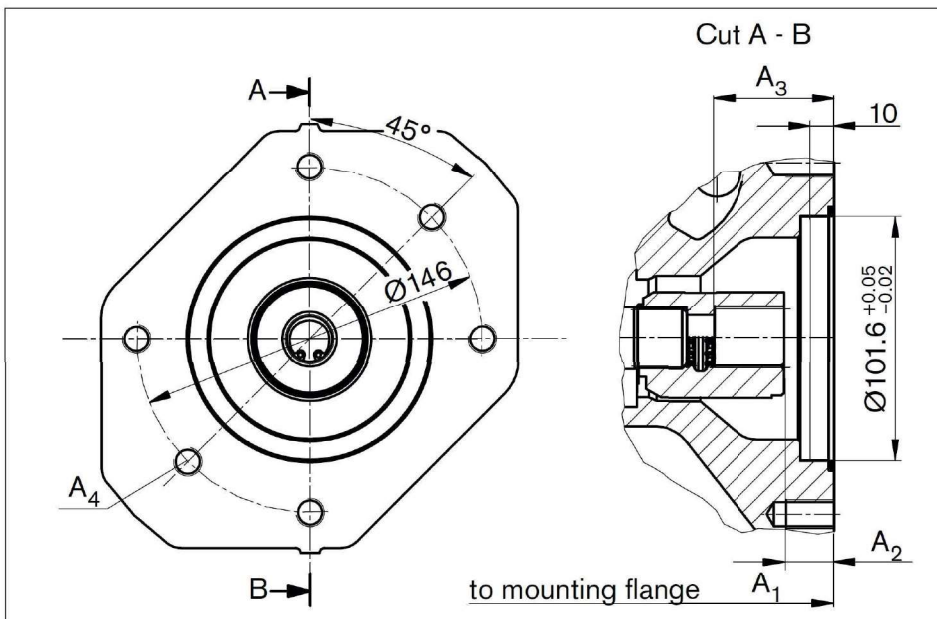

NG	A ₁	A ₂	A ₃	A ₄ ²⁾
45	229	18.4	46.7	M12 x 1.75, 18 deep
71	267	20.8	49.1	M12 x 1.75, 20 deep
100	338	18.2	46.6	M12 x 1.75, 20 deep
140	350	18.3	45.9	M12 x 1.75, 20 deep

1) 30° pressure angle, flat root, side fit, tolerance class 5

2) Thread according to DIN 13, observe the general instructions on page 47 for the maximum tightening torques.

■ Dimensions...though drive K07:

□ Flange ISO 3019-2 (SAE J744-127-2 C)

□ Coupling for splined shaft according to ANSI B92.1a-1996 1-1/4" 14T 12/24 DP¹⁾
(SAE J744-32-4 C)

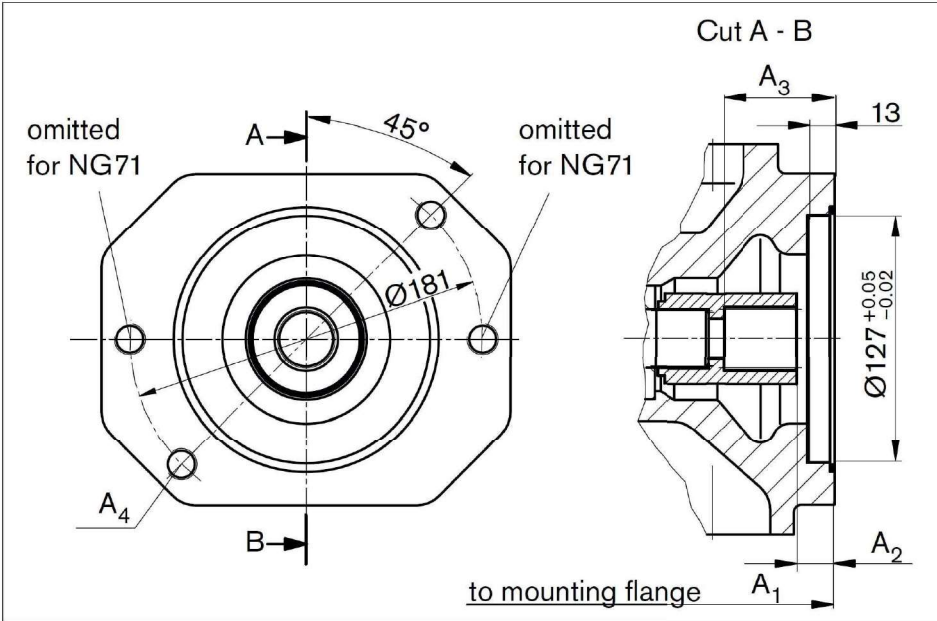

NG	A ₁	A ₂	A ₃	A ₄ ²⁾
71	267	21.8	58.6	M16 x 2, continuous
100	338	19.5	56.4	M16 x 2, continuous
140	350	19.3	56.1	M16 x 2, 24 deep

- 1) 30° pressure angle, flat root, side fit, tolerance class 5
- 2) Thread according to DIN 13, observe the general instructions on page 47 for the maximum tightening torques.

■ Dimensions...though drive K24:

□ Flange ISO 3019-2 (SAE J744-127-2 C)

□ Coupling for splined shaft according to ANSI B92.1a-1996 1-1/2" 17T 12/24 DP¹⁾
(SAE J744-38-4 C-C)

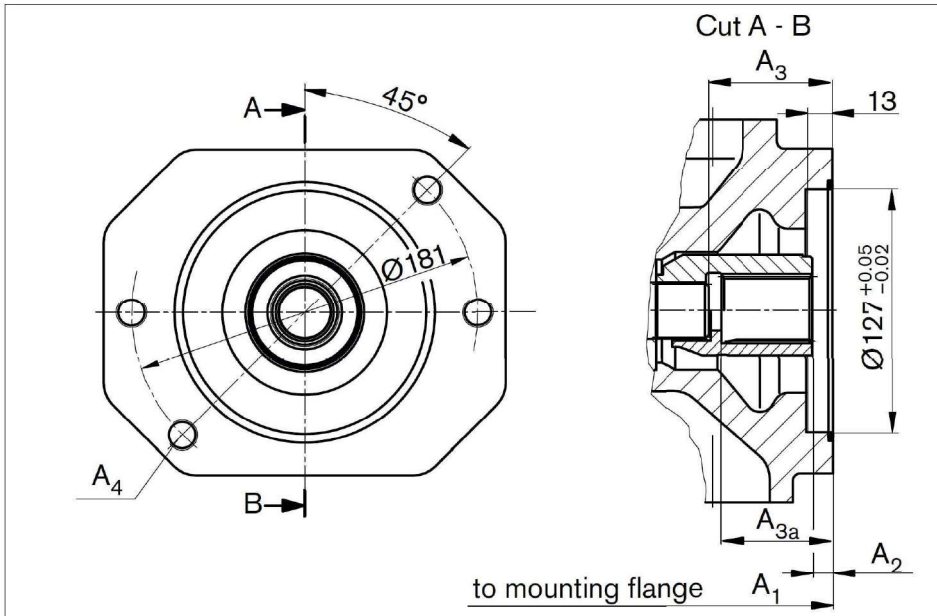

NG	A ₁	A ₂	A ₃ ³⁾	A _{3a} ⁴⁾	A ₄ ²⁾
100	338	10.5	65	-	M16 x 2, continuous
140	350	10.8	75	-	M16 x 2, 24 deep
	350	10.3	-	69.1	M16 x 2, 24 deep

- 1) 30° pressure angle, flat root, side fit, tolerance class 5
- 2) Thread according to DIN 13, observe the general instructions on page 47 for the maximum tightening torques.
- 3) Coupling without stop
- 4) Coupling with stop

■ Dimensions...though K17:

- Flange ISO 3019-2 (SAE J744-152-4 A)
- Coupling for splined shaft according to ANSI B92.1a-1996 1-3/4" 13T 8/16 DP¹⁾ (SAE J744-44-4 D)

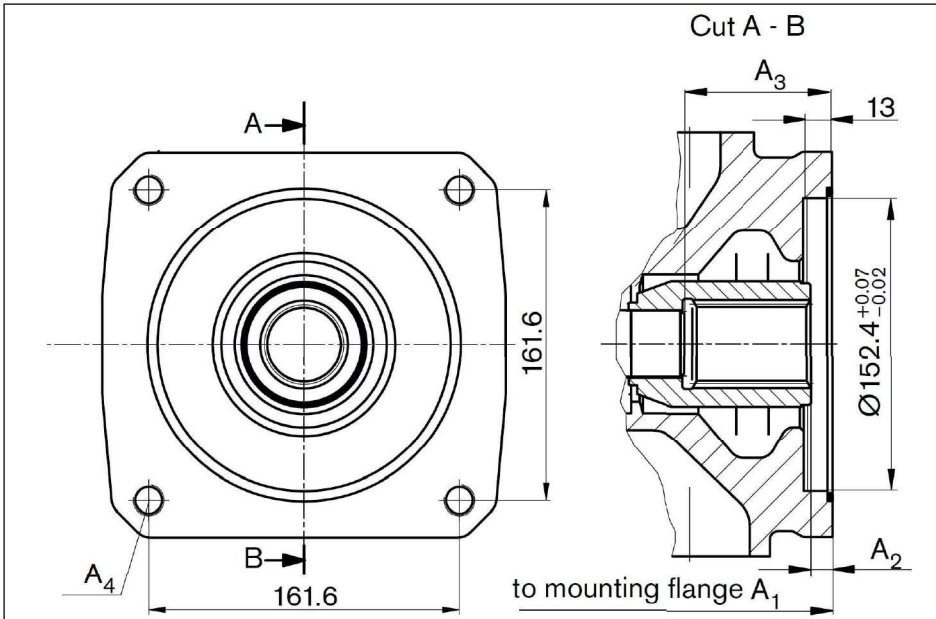

NG	A ₁	A ₂	A ₃	A ₄ ²⁾
140	350	11	77.3	M6 x 2, continuous

1) 30° pressure angle, flat root, side fit, tolerance class 5

2) Thread according to DIN 13, observe the general instructions on page 47 for the maximum tightening torques.

■ Dimensions...though K57:

- Metric 4-hole flange for mounting an R4 radial piston pump
- Coupling for metric shaft key

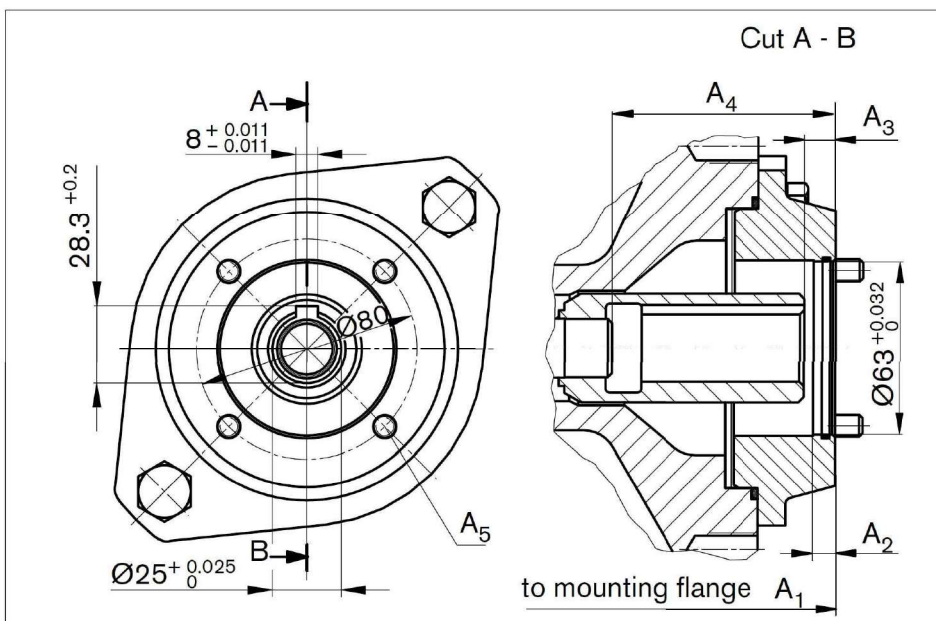

NG	A ₁	A ₂	A ₃	A ₄	A ₅ ³⁾
28	232	8	10.6	58.4	M8
45	257	8	11	81	M8
71	283	8	12.5	77	M10
100	354	8	10.5	81	M10
140	366	8	11	93	M8

1) Screws for mounting the radial piston motor are included in the delivery contents.

■ Dimensions...though KB2:

- Flange ISO 3019-2 80A2SW
- Coupling for splined shaft according to B92.1a-1996 3/4"11T 16/32 DP¹⁾ (SAE J744-19-4 A-B)

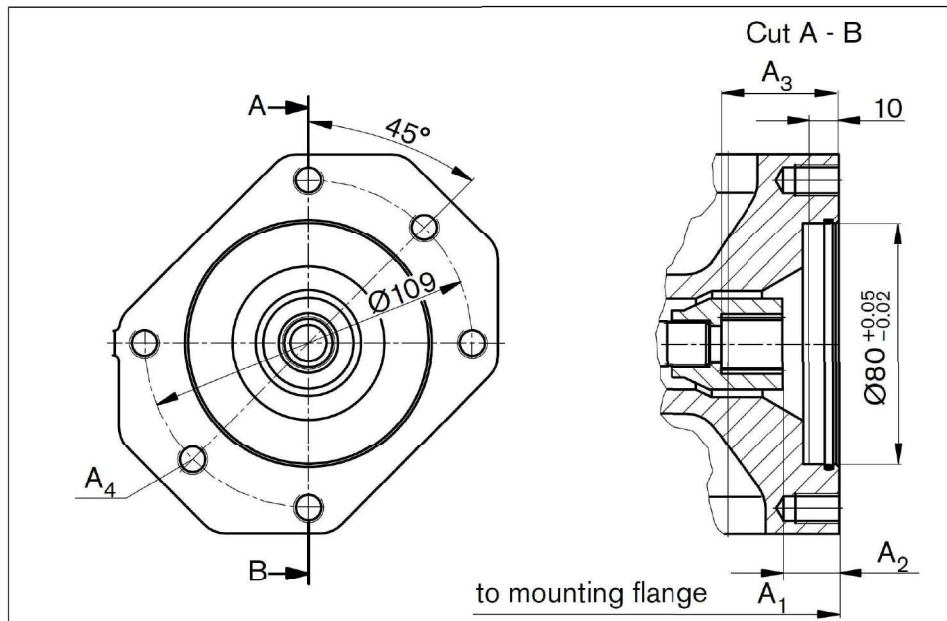

NG	A ₁	A ₂	A ₃	A ₄ ²⁾
18	182	18.8	38.7	M10 x 1.5, 14.5 deep
28	204	18.8	38.7	M10 x 1.5, 16 deep
45	229	18.9	38.7	M10 x 1.5, 16 deep
71	267	21.3	41.4	M10 x 1.5, 20 deep
100	338	19	38.9	M10 x 1.5, 20 deep
140	350	18.9	38.6	M10 x 1.5, 20 deep

- 1) 30° pressure angle, flat root, side fit, tolerance class 5
- 2) Thread according to DIN 13, observe the general instructions on page 47 for the maximum tightening torques.

■ Dimensions...though KB3:

- Flange ISO 3019-2 100A2SW
- Coupling for splined shaft according to ANSI B92.1a-1996 7/8" 13T 16/32 DP¹⁾ (SAE J744-22-4 B)

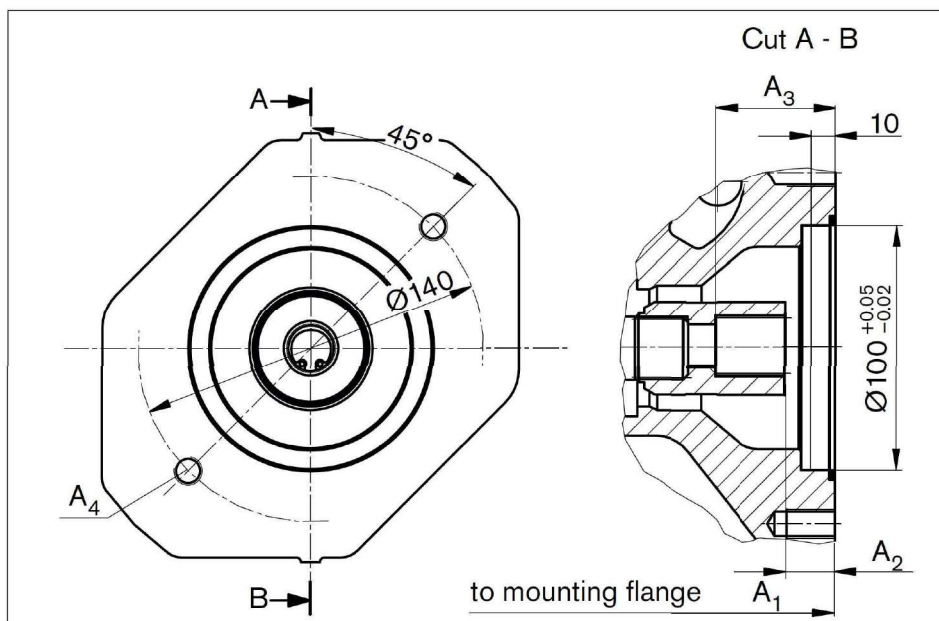

NG	A ₁	A ₂	A ₃	A ₄ ²⁾
28	204	17.8	41.7	M12 x 1.5, continuous
45	229	17.9	41.7	M12 x 1.5, continuous
71	267	20.3	44.1	M12 x 1.5, 20 deep
100	338	18	41.9	M12 x 1.5, 20 deep
140	350	17.8	41.6	M12 x 1.5, 20 deep

- 1) 30° pressure angle, flat root, side fit, tolerance class 5
- 2) Thread according to DIN 13, observe the general instructions on page 47 for the maximum tightening torques.

■ Dimensions...though KB4:

□ Flange ISO 3019-2 100A2SW

□ Coupling for splined shaft according to ANSI B92.1a-1996 1" 15T 16/32 DP¹⁾ (SAE J744-25-4 B-B)

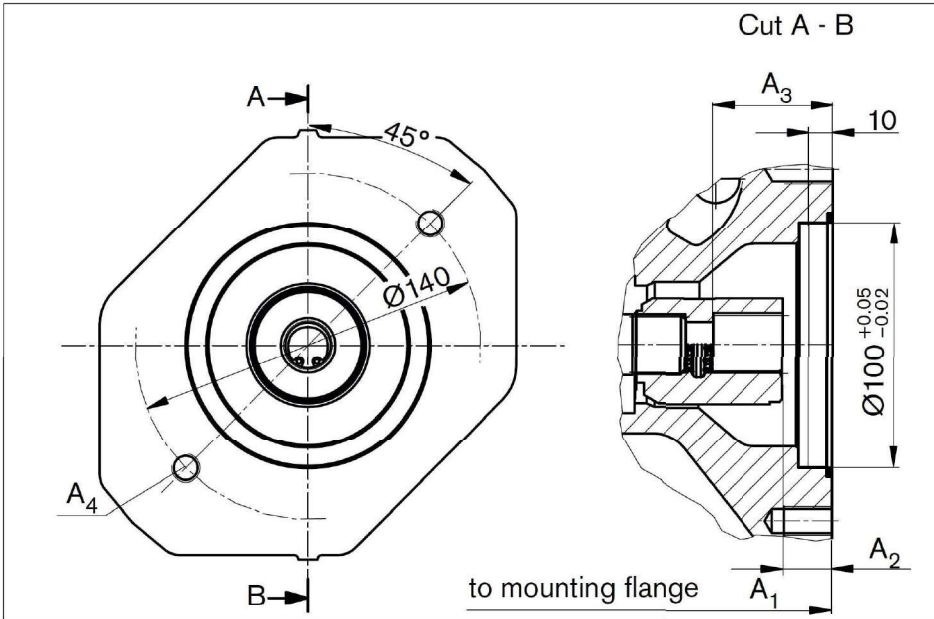

NG	A ₁	A ₂	A ₃	A ₄ ²⁾
45	229	18.4	46.7	M12 x 1.75, continuous
71	267	20.8	49.1	M12 x 1.75, 20 deep
100	338	18.2	46.6	M12 x 1.75, 20 deep
140	350	18.3	45.9	M12 x 1.75, 20 deep

- 1) 30° pressure angle, flat root, side fit, tolerance class 5
- 2) Thread according to DIN 13, observe the general instructions on page 47 for the maximum tightening torques.

■ Dimensions...though KB5:

□ Flange ISO 3019-2 125A2SW

□ Coupling for splined shaft according to ANSI B92.1a-1996 1-1/4" 14T 12/24 DP¹⁾ (SAE J744-32-4 C)

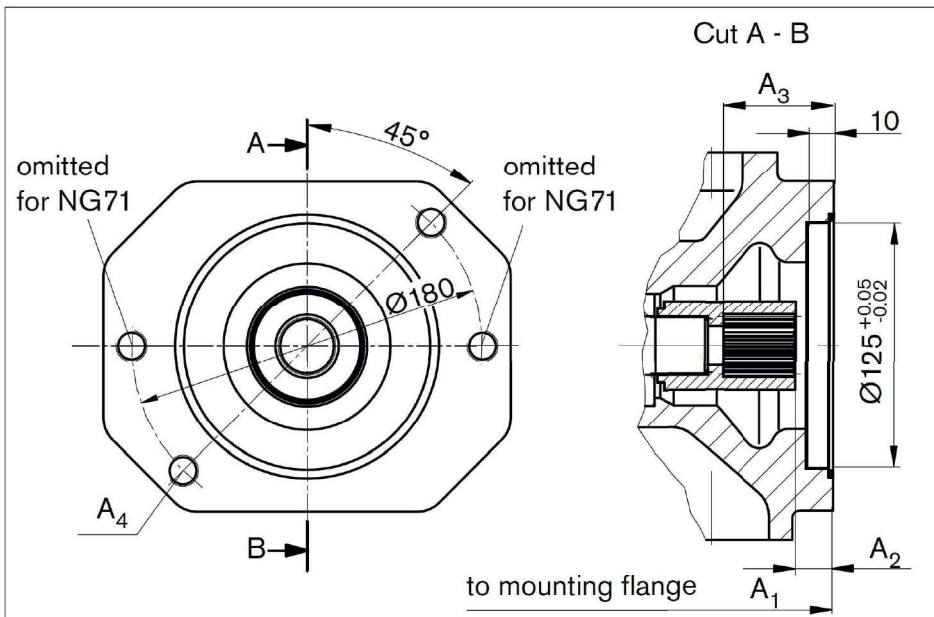

NG	A ₁	A ₂	A ₃	A ₄ ²⁾
71	267	21.8	58.6	M16 x 2, continuous
100	338	19.5	56.4	M16 x 2, continuous
140	350	19.3	56.1	M16 x 2, 24 deep

- 1) 30° pressure angle, flat root, side fit, tolerance class 5
- 2) Thread according to DIN 13, observe the general instructions on page 47 for the maximum tightening torques.

■ Dimensions...though KB6:

□ Flange ISO 3019-2 125A2SW

□ Coupling for splined shaft according to ANSI B92.1a-1996 1-1/2" 17T 12/24 DP¹⁾
(SAE J744-38-4 C-C)

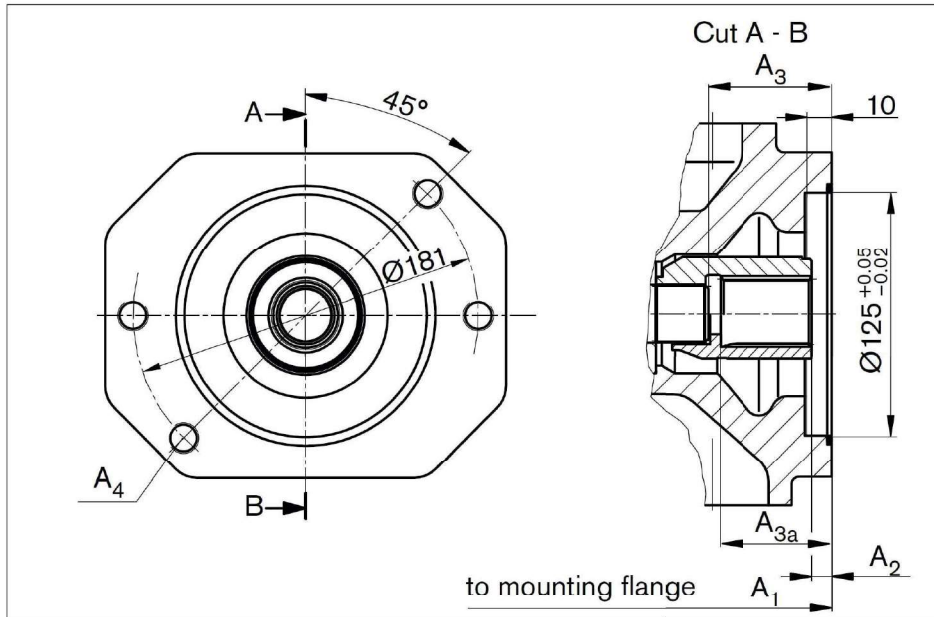

NG	A ₁	A ₂	A ₃ ³⁾	A _{3a} ⁴⁾	A ₄ ²⁾
100	338	10.5	65	-	M16 x 2, continuous
140	350	10.8	75	-	M16 x 2, 24 deep
	350	10.3	-	69.1	M16 x 2, 24 deep

- 1) 30° pressure angle, flat root, side fit, tolerance class 5
- 2) Thread according to DIN 13, observe the general instructions on page 47 for the maximum tightening torques.
- 3) Coupling without stop
- 4) Coupling with stop

■ Dimensions...though KB7:

□ Flange ISO 3019-2 180B4HW

□ Coupling for splined shaft according to ANSI B92.1a-1996 1-3/4" 13T 8/16 DP¹⁾
(SAE J744-44-4 D)

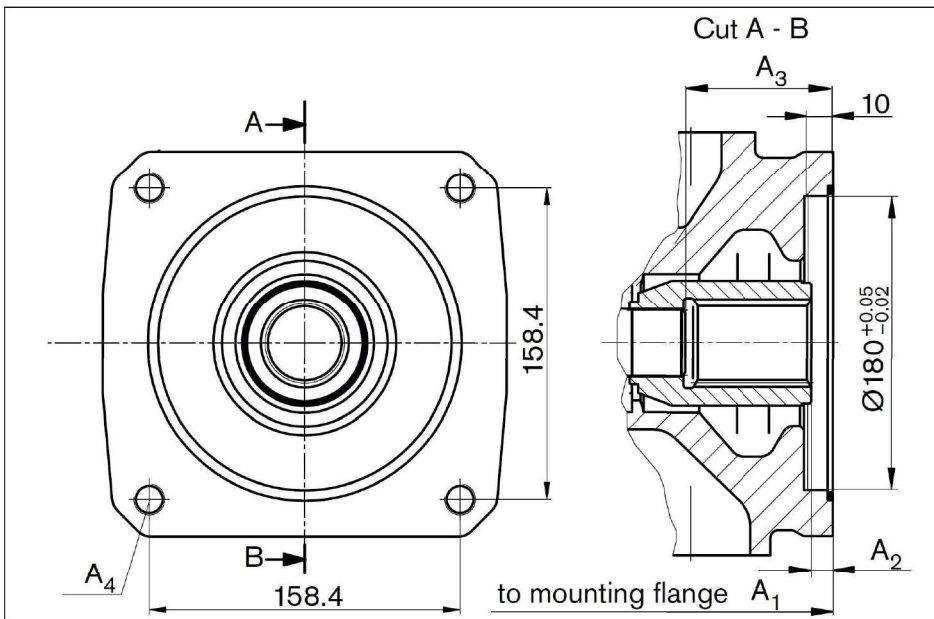

NG	A ₁	A ₂	A ₃	A ₄ ²⁾
140	350	11.3	77.3	M16 x 2, continuous

- 2) Thread according to DIN 13, observe the general instructions on page 47 for the maximum tightening torques.

■ Summary mounting options:

□ SAE – mounting flange

Through-drive ¹⁾			Mounting option – 2nd pump			
Flange ISO 3019-1	Coupling for splined shaft	Short des.	AH10VO/31 NG (shaft)	AH10V(S)O/5x NG (shaft)	External gear pump design (NG)	Through drive available for NG
82-2 (A)	5/8 in	K01	18 (U)	10 (U)	F (5 to 22)	18 to 140
	3/4 in	K52	18 (S, R)	10 (S) 18 (U) 18 (S, R)	–	18 to 140
101-2 (B)	7/8 in	K68	28 (S, R) 45 (U, W) ¹⁾	28 (S, R) 45 (U, W) ¹⁾	N/G (26 to 49)	28 to 140
	1 in	K04	45 (S, R) –	45 (S, R) 60, 63 (U, W) ²⁾	–	45 to 140
127-2 (C)	1 1/4 in	K07	71 (S, R) 100 (U) ³⁾	85 (U, W) ³⁾ 100 (U, W)	–	71 to 140
	1 1/2 in	K24	100 (S)	85 (S) 100 (S)	–	100 to 140
152-4 (4-hole D)	1 3/4 in	K17	140 (S)	–	–	140

1) Not for main pump NG28 with K68

2) Not for main pump NG45 with K04

3) Not for main pump NG71 with K07

□ ISO – mounting flange

Through-drive ¹⁾			Mounting option – 2nd pump			
Flange ISO 3019-2	Coupling for splined shaft	Short des.	AH10VO/31 NG (shaft)	AH10V(S)O/5x NG (shaft)	Gear pump design (NG)	Through drive available for NG
80-2	3/4 in	KB2	18 (S, R)	10 (S)	–	18 to 140
100-2	7/8 in	KB3	28 (S, R)	–	–	28 to 140
	1 in	KB4	45 (S, R)	–	–	45 to 140
125-2	1 1/4 in	KB5	71 (S, R)	–	–	71 to 140
	1 1/2 in	KB6	100 (S)	–	–	100 to 140
180-4 (4-hole B)	1 3/4 in	KB7	140 (S)	–	–	140

□ Shaft key:

Through-drive ¹⁾			Mounting option – 2nd pump			
Flange ISO 3019-2	Coupling for shaft key	Short des.	AH10VO/31 NG (shaft)	AH10V(S)O/5x NG (shaft)	Radial piston pump	Through drive available for NG
80-2	3/4 in	K57	–	–	R4	28 to 140

■ **Though drives:**

- ❑ The type of though drive is determined by code "K**".
- ❑ If no further pumps are to be factory-mounted, the simple type code is sufficient. Include in this case are: shaft coupler, fastening screw, seals, and if necessary an adapter flange.

■ **Combination pumps:**

- ❑ It is possible to have multiple, mutually independent circuits when using combination pumps.
- ❑ When ordering combination pumps the model codes for the first and the second pump must be joined by a "+".
- ❑ If there's a need for combination of gear pumps or piston pumps in factory, please contact us

■ For combination pumps comprising more than two pumps, the mounting flange must be calculated for the permissible moment of inertia.

■ **Permissible mass moment of inertia:**

NG			18	28	45	71	100	140
Permissible mass moment of inertia								
static	T_m	Nm	500	880	1370	2160	3000	4500
dynamic at 10 g (98.1 m/s ²)	T_m	Nm	50	88	137	216	300	450
Mass with through-drive plate	m	kg	14	19	25	39	54	68
Mass without through drive (e.g. 2nd pump)	m	kg	12	15	21	33	45	60
Distance center of gravity	l	mm	90	110	130	150	160	160

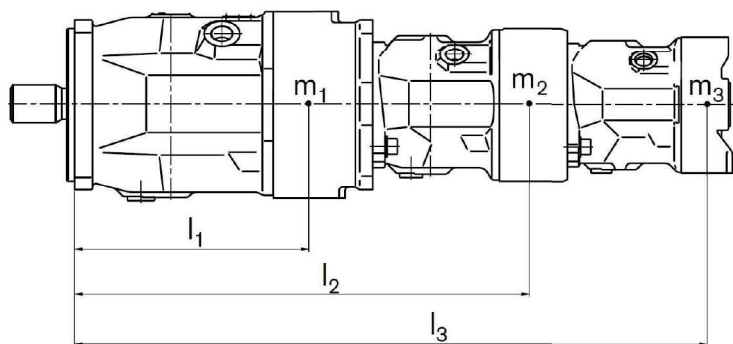

m_1, m_2, m_3 Mass of pumps [kg]

l_1, l_2, l_3 Distance center of gravity [mm]

$$T_m = (m_1 \cdot l_1 + m_2 \cdot l_2 + m_3 \cdot l_3) \cdot \frac{1}{102} \text{ [Nm]}$$

■ Selection of hydraulic fluid:

■ Classification of hydraulic oil:

- Hydraulic oil suitable for axial piston pump :
- Hydraulic fluids based on mineral
- Environmentally acceptable hydraulic fluids:
 - ✚ Synthetic hydraulic fluids based on esters, HEES.
 - ✚ Synthetic hydraulic fluids based on Polyglycol, HEPG.
 - ✚ Synthetic hydraulic fluids based on Vegetable, HETG
- Fire-resistant, water-containing hydraulic fluids:

Code	Type of Fluid	Water content (wt%)
HFA	oil-in-water emulsion	95...98
HFB	water-in-oil emulsion	>40
HFC	water-based solutions	35...55
HFD	water-free fluids	≤0.1

■ Selection of Fluids:

- In order to ensure the high work efficiency , the selection of fluids should base on the working conditions , such as the viscosity and viscosity - temperature curve, the density, and pour point should also be considered.
- All mineral oil based fluids are suitable to a greater or lesser degree for applications with axial piston units. Their basic classification of application results from what has already been said due to the water, viscosity and temperature relationships, with consideration of oxidization and corrosion protection, material compatibility, air and water separation characteristics.
- Axial piston pump on operation with oil-in-water emulsion (HFA), water-in-oil emulsion (HFB), water-based solution (HFC) or environmentally acceptable hydraulic fluids, to consider the axial piston pump technology data restriction or reduced. HUADE hydraulic technology necessary contact consulting.

■ Operating viscosity range:

- In order to obtain optimum efficiency and service life, we recommend that the operating viscosity (at operating temperature) be selected in the range.

$v_{opt} = \text{opt. viscosity range } 16...36 \text{ mm}^2/\text{s}$

referred to tank temperature (open circuit).

- Limit of viscosity range:

$V_{min} = 10 \text{ mm}^2/\text{s}$, for short periods ($t < 3 \text{ min}$)

at max. permissible case drain temperature 90°C

$V_{max} = 1000 \text{ mm}^2/\text{s}$, for short periods, on cold start ($t_{min} = -25^\circ\text{C}$)

- Temperature range:

$t_{min} = -25^\circ\text{C}$

$t_{max} = 90^\circ\text{C}$

■ Mechanical displacement limiter:

- Mechanical displacement limiter is standard on the non-through drive model N00, but not possible for the model with through drive.

$V_{g \text{ max}}$: For size 18...140

Setting range from $V_{g \text{ max}}$ to $50\% V_{g \text{ max}}$ stepless

$V_{g \text{ min}}$: For size 100...140

Setting range from $V_{g \text{ min}}$ to $50\% V_{g \text{ min}}$ stepless

■ Selection diagram:

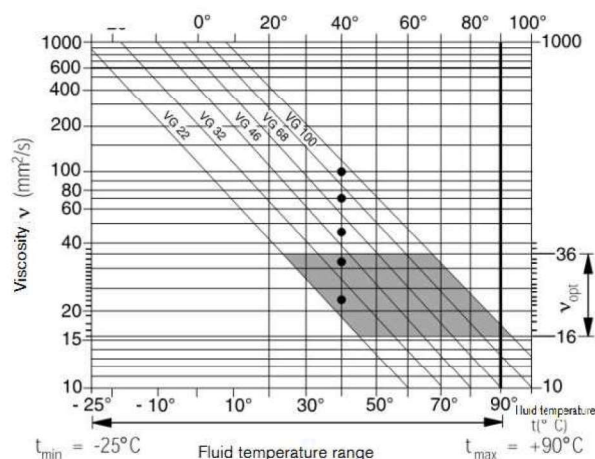

- Selection of hydraulic fluid:

✚ In order to select the correct hydraulic fluid, it is necessary to know the operating temperature in relation to the ambient temperature. In an open circuit this is the reservoir temperature.

✚ The fluid should be selected so that within the operating temperature range, the viscosity lies within the optimum range (v_{opt}), see shaded section of the selection diagram. We recommend to select the higher viscosity grade in each case.

✚ Example: at an ambient temperature of X °C the operating temperature in the reservoir is 60°C . In the optimum operating viscosity range (v_{opt} ; shaded area) this corresponds to viscosity grades VG 46 resp. VG 68; VG 68 should be selected.

- Important:

✚ The case drain temperature is influenced by pressure and input speed and is always higher than the reservoir temperature. However, at no point in the component may the temperature exceed 90°C

✚ Please contact us if the above conditions cannot be met due to extreme operating parameters.

■ Filtration of the hydraulic fluid:

- The finer the filtration the better the fluid cleanliness class and the longer the service life of the axial piston unit.

- To ensure the functioning of the axial piston unit a minimum purity grade of:

✚ NAS 1638 9

✚ SAE 6

✚ ISO/DIS 4406 to 18/15

- At very high temperatures of the hydraulic fluid (90°C to max. 115°C) at least cleanliness class:

✚ NAS 1638 8

✚ SAE 5

✚ ISO/DIS 4406 17/14

- Please contact us if the above classes cannot be observed

■ General safety instructions

- The axial piston unit has been manufactured according to the generally accepted rules of current technology. There is, however, still a danger of personal injury or damage to equipment if the following general safety instructions and the warnings before the steps contained in these instructions are not complied with.

✚ Read this documentation completely and thoroughly before working with the axial piston unit.

✚ Keep these instructions in a location where they are accessible to all users at all times.

✚ Always include the required documentation when you pass the axial piston unit on to third parties.

■ Intended use:

- Axial piston units is exclusively intended for being integrated in a machine or system or for being assembled with other components to form a machine or system. The product may only be commissioned after it has been installed in the machine/system for which it is intended.
- The axial piston unit is only approved as a pump for hydrostatic drives in open circuit.

✚ Observe the technical data, operating conditions and performance limits as specified in the data sheet and order confirmation.

- The axial piston unit is only intended for professional use and not for private use.

- Intended use includes having read and understood these instructions, especially chapter "General safety instructions".

■ Improper use:

- Any use other than that described as intended use shall be considered as improper and is therefore impermissible.

- Supplier hydraulic shall accept no liability whatsoever for damage resulting from improper use. The user shall bear all risks arising from improper use.

- Similarly, the following foreseeable faulty usages are also considered to be improper:

✚ Using outside the operating parameters approved in the data sheet (unless customer-specific approval has been granted).

✚ Use for non-approved fluids, e.g. water or polyurethane components.

✚ Modification of factory settings by non-authorized persons.

✚ Use of add/on parts (e.g. mountable filter, control unit, valves) that are not specified components.

✚ Using the axial piston unit under water at a depth of more than 10 meters without necessary additional measures, e.g. pressure equalization.

✚ Using the axial piston unit when the exterior pressure is greater than the interior pressure (case pressure).

✚ Using the axial piston unit in explosive environments unless the component or machine/system has been certified as compliant with the ATEX directive 94/9/EC.

✚ Using the axial piston unit in an aggressive atmosphere.

✚ Using the axial piston unit in aircraft or space craft

■ Personnel qualifications:

- The activities described in this documentation require basic mechanical, electrical and hydraulic knowledge, as well as knowledge of the associated technical terms.

- For transporting and handling the product, additional knowledge is necessary with regard to working with a lifting device and the corresponding attachment equipment.

- Qualified personnel are those who can recognize possible hazards and institute the appropriate safety measures due to their professional training, knowledge, and experience, as well as their understanding of the relevant regulations pertaining to the work to be done. Qualified personnel must observe the rules relevant to the subject area and have the necessary hydraulic knowledge.

■ General safety instructions:

- Observe the applicable accident prevention and environmental protection regulations.

- Observe the safety regulations and provisions of the country in which the product is used/operated.

- Use products only when they are in good technical order and condition.

- Observe all notes on the product. Inspect the product for obvious defects.

- Do not modify or retrofit the axial piston unit.

- Conform to the technical data and ambient conditions specified in the product documentation.

- Persons who install, operate, remove or maintain HUADE products must not consume any alcohol, drugs or pharmaceuticals that may affect their ability to respond.

- Only use original accessories and spare parts to ensure there is no risk to persons from unsuitable spare parts.

- If unsuitable products are installed or used in applications that are of relevance to safety, unexpected operating conditions may occur in the application which could result in injury to persons or property damage. For this reason, only use the product in a safety-relevant application if this use is expressly specified and permitted in the product documentation, for example in ex-protection applications or in safety-related parts of a control system (functional safety).

- You may only commission the product if it has been determined that the end product (e.g. machinery or a system) into which the products are installed complies with the country-specific provisions, safety regulations and standards of the application.

- Pressure cut-off and pressure control do not provide security against pressure overload. A separate pressure relief valve is to be provided in the hydraulic system.

■ Product-specific safety instructions:

- Never apply to the product of any mechanical load. Never stand under or put you hands under suspended loads. Do not place or stack any object on the top the product.

- The noise emission of axial piston units depends on speed, operating pressure and installation conditions. The sound pressure level may rise above 70 dBA during normal application conditions.

- Always wear hearing protection when in the vicinity of the operating axial piston unit.

- Hot surfaces on the axial piston unit! There is a risk of burns when the operating solenoid valves upon pump became overheated.

✚ Allow the axial piston unit to cool down sufficiently before touching it.

✚ Wear heat-resistant protective clothing, e.g. gloves.

■ During transport:

- Make sure that the lifting device has adequate lifting capacity. The weight can be found in chapter "Transport and storage".

■ During assembly:

- Before assembling, make sure that all fluids have been completely removed from the axial piston unit to prevent mixing with the hydraulic fluid used in the system.
- Make sure the relevant system component is not under pressure or voltage before assembling the product or when connecting and disconnecting plugs. Protect the system against being switched on.
- Make sure that nobody will damage or trip over when laying of cables and pipeline.
- Before commissioning, make sure that all electrical and hydraulic ports are connected or plugged to prevent leakage, prevents liquid and dirt penetrate into the product.
- When assembling, provide for absolute cleanliness in order to prevent contaminants such as welding beads or metal cuttings from getting into the hydraulic lines and causing product wear or malfunctions.

■ During commissioning:

- Make sure that all electrical and hydraulic ports are connected or plugged. Only commission a completely installed product.

■ During cleaning:

- Check whether all seals and fittings on the connections are securely seated to ensure that no moisture can penetrate into the axial piston unit during cleaning.
- Use only water and, if necessary, a mild detergent to clean the axial piston unit. Never use solvents or aggressive detergents.
- Do not point the power washer at sensitive components, e.g. shaft seal, electrical connections and components.

■ Maintenance and repair

- Carry out the specified inspection and maintenance work at the intervals described in this manual(see chapter " Maintenance").
- Make sure that all the lines, connections or components are connected as long as the system is under pressure. Protect the system against being switched on.

■ Disposal:

- Dispose of the axial piston unit and packaging material in accordance with the national regulations in your country.

■ Operator's obligations

- The operator of the axial piston unit from must provide personnel training on a regular basis regarding the following subjects:
 - Observation and use of the operating instructions and the legal regulations Intended use and operation of the axial piston unit .
 - Observation of the instructions from the factory security offices and of the work instructions from the operator.

■ Delivery contents:

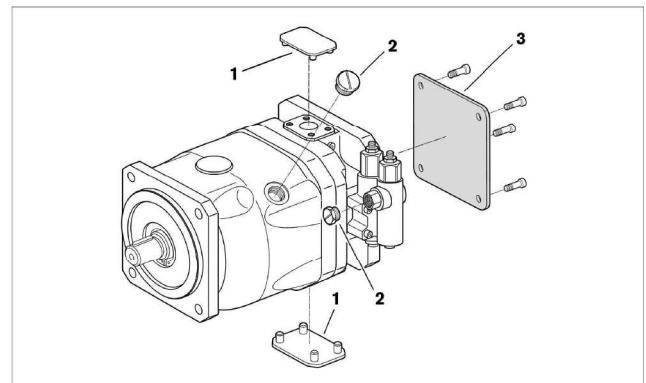

- Included in the delivery contents are:

- ✚ Axial piston unit as per order confirmation

- The following parts are also installed on delivery:

- ✚ Protective covers made of plastic (1) (metal protective covers are used for painted axial piston units)

- ✚ Protective plug/threaded plug (2)

- ✚ On version with through drive, metallic protective cover and fixing screws (3) at the through drive

■ Performance description:

- The Axial piston variable pump generates, controls and regulates a hydraulic fluid flow. The AH10VO is designed for mobile applications such as construction machinery. The AH10VSO is designed for stationary applications such as tooling machines.
- Refer to data sheets and the order confirmation for the technical data, operating conditions and operating limits of the axial piston unit.

■ Product description:

- The AH10V(S)O are variable pumps with axial piston rotary group in swashplate design for hydrostatic drive in an open circuit.
- Flow is proportional to drive speed and displacement. The flow can be steplessly changed by adjusting the swashplate.

■ Open circuit:

- In an open circuit, the hydraulic fluid flows from the reservoir to the hydraulic pump from where it is fed to the consumer, e.g. hydraulic motor. From the consumer, the hydraulic fluid flows directly back to the reservoir.

■ Assembly of the axial piston unit:

- Assembly of the AH10V(S)O:

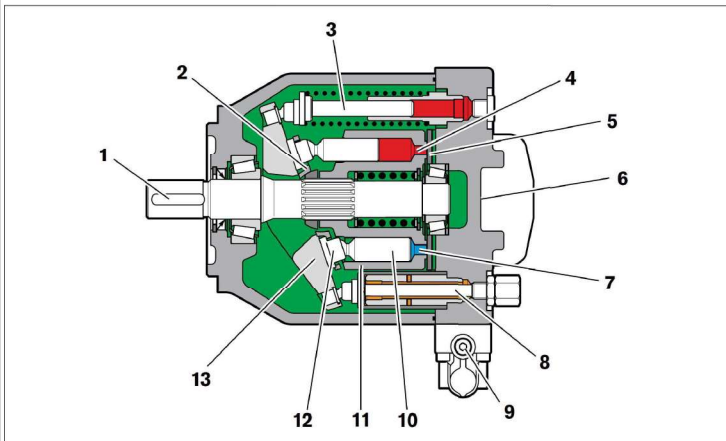

- | | |
|-----------------------|------------------|
| 1. Drive shaft | 8. Stroke piston |
| 2. Retaining plate | 9. Control valve |
| 3. Opposing piston | 10. Piston |
| 4. High-pressure side | 11. Cylinder |
| 5. Control plate | 12. Slipper pad |
| 6. Port plate | 13. Swashplate |
| 7. Suction side | |

- For axial piston units with swashplate design, the pistons (11) are arranged axially with respect to the drive shaft (1). They are guided in the rotating cylinder (10) and support themselves with the slipper pads (12) on the non-rotating swashplate (13). The drive shaft (1) and cylinder (10) are connected to one another by means of gearing.

■ Functional description:

■ Pump:

- Torque and rotational speed are applied to the drive shaft (1) by an engine. The drive shaft is connected by splines to the cylinder (11) to set this in motion. With every revolution, the pistons (10) in the cylinder bores execute one stroke whose magnitude depends on the setting of the swashplate (13). The pistons hold the slipper pads (12) onto the glide surface of the swashplate with the retaining plate (2) and guide them along. The swashplate setting during a rotation causes each piston to move over the bottom and top dead centers and back to its initial position. Here, hydraulic fluid is fed in and drained out through the two control slots in the control plate (5) according to the stroke displacement. On the suction side (7) hydraulic fluid flows into the piston chamber as the piston recedes. At the same time, on the high-pressure side (4) the hydraulic fluid is pushed out of the cylinder chamber into the hydraulic system by the pistons.

■ Control:

- The swivel angle of the swashplate (13) is steplessly variable. Controlling the swivel angle of the swashplate changes the piston stroke and therefore the displacement. The swivel angle is changed hydraulically by means of the stroke piston. The swashplate is mounted for easy motion in swivel bearings and it is kept in balance by the opposing piston (3). Increasing the swivel angle increases the displacement; reducing the angle results in a corresponding reduction in displacement.
- The swivel angle can never be swiveled completely to zero because a minimum amount of hydraulic fluid is necessary for
 - ✚ Cooling the pistons.
 - ✚ Supplying the control.
 - ✚ Compensating for case drain fluid and.
 - ✚ Lubricating all moving parts.

■ Transporting the axial piston unit:

- The transportation options below exist depending on the weight and duration of the transport

- ✚ Transporting by hand

- ✚ Transporting with lifting device (ring screw or lifting strap)

- Dimensions and weights:

Size	10	18	28	45	71	100	140
Weight Kg	8	12	15	21	33	45	60
Width mm	The dimensions vary with the unit type. The values applicable for your axial piston unit can be found in the installation drawing (request if necessary).						
Height mm							
Depth mm							

■ Transporting by hand:

- Axial piston units with a weight of up to 15 kg can be transported manually for a short time if necessary.
- Caution! Danger from heavy loads!
- There is a danger of health damage when carrying axial piston units.
- ✚ Use suitable lifting, placement and relocation equipment.
- ✚ Use your personal protective equipment (e.g. safety glasses, safety gloves, suitable working clothes, safety shoes).
- Do not transport the axial piston unit at sensitive attachment parts (e.g. sensors or valves).
- Carefully place the axial piston unit on the seating to prevent it from being damaged.

■ Transporting with lifting device:

- For transporting, the axial piston unit can be connected to a lifting device via a ring screw or a lifting strap.

■ Transport with ring screw:

- The axial piston unit can be transported suspended from a ring screw screwed into the drive shaft as long as only outward (pulling) axial forces are applied.
- Screw a ring screw completely into the thread on the drive shaft. The thread sizes is stated in the installation drawing.
- Make sure that the ring screw can bear the total weight of the axial piston unit plus 20%.
- You can hoist the axial piston unit as shown in Figure below with the ring screw screwed into the drive shaft without any risk of damage.

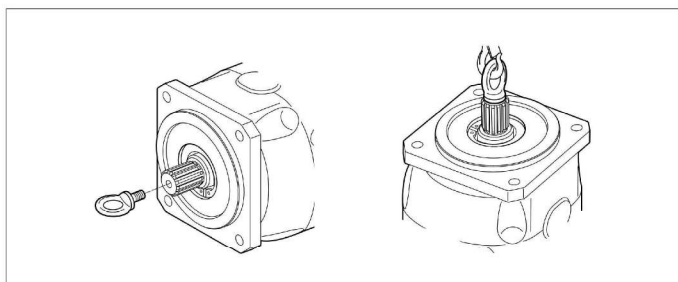

- Fixing the ring screw

■ WARNING ! Risk of injuries!

- ✚ Hitting or impulsive forces on the drive shaft can damage the axial piston unit.

- ✚ Do not hit the coupling or drive shaft of the axial piston unit.

- ✚ Do not set/place the axial piston unit on the drive shaft.

- ✚ See detailed information of the permissible axial and radial force in the data sheet.

■ Transport with lifting strap:

- Place the lifting strap around the axial piston unit in such a way that it passes over neither the attachment parts (e.g. valves) nor such that the axial piston unit is hung from attachment parts (see Figure below).

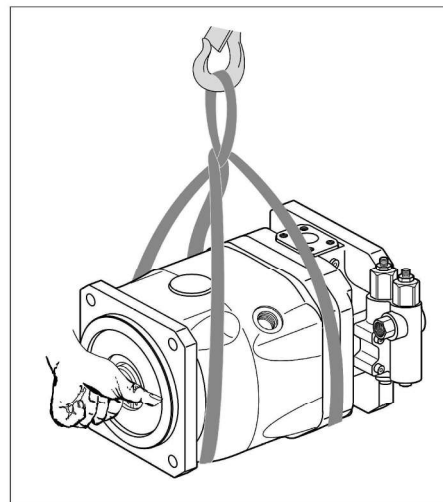

- Transport with lifting strap

■ WARNING! Danger from suspended loads!

- During transport with a lifting device, the axial piston unit can fall out of the lifting strap and cause injuries.

- ✚ Use the widest possible lifting strap.

- ✚ Make sure that the axial piston unit is securely fixated with the lifting strap.

- ✚ Only guide the axial piston unit by hand for fine positioning and to avoid oscillations.

- ✚ Never stand under or put you hands under suspended loads.

■ **Storing the axial piston unit:**

■ **Requirements:**

- The storage areas must be free from corrosive materials and gases.
- To prevent damage to the seals, ozone-forming equipment (e.g. mercury-vapor amps, high voltage equipment, electric motors, sources of electrical sparks or electrical discharges) must not be operated in storage areas.
- The storage areas must be dry.
- Ideal storage temperature: +5 °C ~ +20 °C 。 Minimum storage temperature: -50°C, Maximum storage temperature: +60°C。
- Avoid high light irradiation (e.g. bright windows or direct fluorescent lighting)。
- Do not stack axial piston units and store them shock-proof.
- Do not store the axial piston unit on sensitive attachment parts, e.g. Speed sensors.
- For other storage conditions, see table below.
- Check the axial piston unit monthly to ensure proper storage.

■ **After delivery:**

- The axial piston units are provided ex-works with corrosion protection packaging (corrosion protection film).
- The following table lists the maximum permissible storage times for an originally packed axial piston unit .
- Storage time with factory corrosion protection:

Storage conditions	Standard corrosion protection	Long-term corrosion protection
Closed, dry room, uniform temperature between +5°C and +20°C. Undamaged and closed corrosion protection film.	Maximum 12 months	Maximum 24 months

- Procedure after expiry of the maximum storage time:

1. Check the entire axial piston unit for damage and corrosion prior to installation.
2. Check the axial piston unit for proper function and leaks during a test run.
3. If the storage time exceeds 24 months, the shaft seal ring must be replaced.

■ **After removal**

- If a removed axial piston unit is to be stored, it must be conserved against corrosion for the duration of the storage.
- recommend the following procedure:
 1. Clean the axial piston unit, see chapter " Cleaning and care" for further information.
 2. Completely empty the axial piston unit.
 3. For storage time up to 12 months: Moisten the inside of the axial piston unit with mineral oil and fill with approx. 100 ml mineral oil.
For storage time up to 24 months: Fill the axial piston unit with corrosion protection VCI 329 (20 ml). Fill via case drain port K₁ or K₂, see chapter "Assembling the axial piston unit".
 4. Seal all ports airtight.
 5. Moisten the unpainted surfaces of the axial piston unit with mineral oil.
 6. Package the axial piston unit airtight together with desiccant in corrosion protection film.
 7. Store the axial piston unit so that it is protected against jolts. See "Requirement" in this chapter for further conditions.

■ Assembly

- Prior to assembly, the following documents must be available:

- ✚ Installation drawing for the axial piston unit
- ✚ Hydraulic circuit diagram for the axial piston unit (in the installation drawing) .
- ✚ Hydraulic circuit diagram for the system (available from the system manufacturer).
- ✚ Order confirmation (contains the preset data of the axial piston unit)
- ✚ Data sheet for the axial piston unit (contains the technical data)

■ Unpacking

- ✚ The axial piston unit is delivered in a corrosion protection film made of polyethylene material.
- ✚ Remove the packaging from the axial piston unit.
- ✚ Check the axial piston unit for transport damage and completeness, see chapter "Delivery contents".
- ✚ Dispose of the packaging according to the national regulations of your country.

■ Caution! Danger from parts falling out!

- ✚ If the packaging is not opened correctly, parts may fall out and damage the parts or even cause injuries!
- ✚ Place the packaging on a flat and solid surface.
- ✚ Only open the packaging from the top.

■ Installation conditions:

- The installation location and position of the axial piston unit essentially determine the procedures during installation and commissioning (such as when filling and air bleeding the axial piston unit).
- Note that you can expect certain installation positions to affect the control device. Because of gravity, dead weight and case pressure, minor characteristic displacements and actuating time changes may occur.
- Adhere to all limits specified in the data sheet regarding temperature, viscosity, cleanliness of the hydraulic fluid.
- Fix the axial piston unit so that the expected forces and torques can be transferred without any danger. The machine/system manufacturer is responsible for dimensioning the fasteners.
- Observe the permissible radial forces on the drive shaft when transferring output drive with radial loading (belt drives). If necessary, the belt pulley must be separately mounted.
- Make sure that the axial piston unit is air bled and filled with hydraulic fluid during commissioning and operation. This is also to be observed following relatively long standstill periods as the axial piston unit may empty via the hydraulic lines.
- The case drain fluid in the case interior must be directed to the reservoir via the highest case drain port. Use the line size which is appropriate for the port.
- A check valve in the reservoir line is not permissible.
- To achieve favorable noise values, decouple all connecting lines from all vibration-capable components (e.g. reservoir) using elastic elements.
- Make sure that the suction, reservoir and return lines lead into the reservoir below the minimum fluid level in all operating conditions. This will prevent air from being drawn in and foam from being formed.

□ Suction pressure:

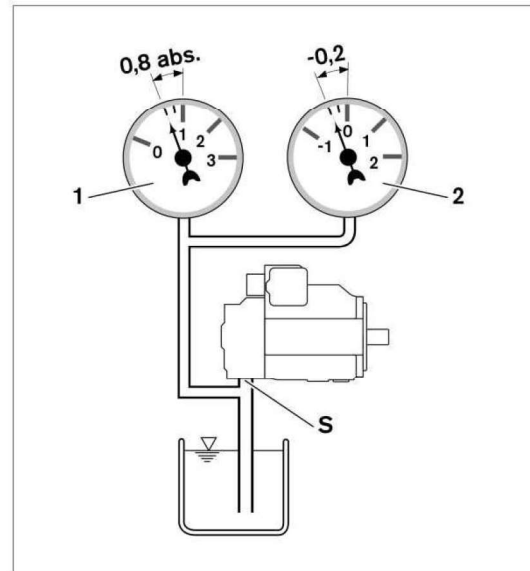

1. Absolute pressure gauge
2. Standard pressure gauge

- Make sure that a minimum suction pressure of 0.8 bar absolute is present at port S during operation for all installation positions and installation locations of the axial piston pump; see Figure above. See data sheet for pressure values.
- The suction conditions improve with below- and inside-reservoir installation
- Make sure that the working environment at the installation site is fully free of dust and foreign substances. The axial piston unit must be installed in a clean condition. Dirt contamination in the hydraulic fluid can seriously impair the function and service life of the axial piston unit.
- Use lint-free cloths for cleaning.
- Use suitable mild detergents to remove lubricants and other difficult-to-remove contamination. Cleaning agents must not enter the hydraulic system.

■ Installation instructions:

■ General Instructions:

- ❑ The axial piston unit must be filled with hydraulic fluid and air bled during commissioning and operation. This must also be observed following a longer standstill as the axial piston unit empty via the hydraulic lines.
- ❑ Especially with the installation position "drive shaft upwards" or "drive shaft downward", attention must be paid to a complete filling and air bleeding since there is a risk for example, of dry running.
- ❑ The case drain fluid in the motor housing must be directed to the reservoir via the highest case drain port (L₁, L₂, L₃).
- ❑ For combinations of multiple units, make sure that the respective case pressure in each unit is not exceeded. In the event of pressure differences at the case drain ports of the units, the shared case drain line must be changed so that the minimum permissible case pressure of all connected units is not exceeded in any situation. If this is not possible, separate case drain lines must be laid if necessary.
- ❑ To achieve favorable noise values, decouple all connecting lines using elastic elements and avoid above-reservoir installation.
- ❑ In all operating conditions, the suction line and case drain line must flow into the reservoir below the minimum fluid level. The permissible suction height h_s is a result of the overall pressure loss, but may not be greater than h_{smax} = 800mm. The minimum suction pressure at port S must also not fall below 0.8 bar absolute during operation.

■ Installation position:

- ❑ See the following examples 1 to 15. Additional installation positions are available upon request.
- ❑ Recommended installation positions: 1 and 3.

■ Below-tank installation(standard):

- ❑ Below-reservoir installation means the axial piston unit is installed outside of the reservoir below the minimum fluid level.
- ❑ In this case, Port L / L₁ and S must be connected with pipelines, please refer to figures below.
- ❑ Recommended installation positions: 1 and 3.
- ❑ The axial piston unit must be filled with hydraulic fluid during the first operation.

❑ Below-reservoir installation with installation position 1–5

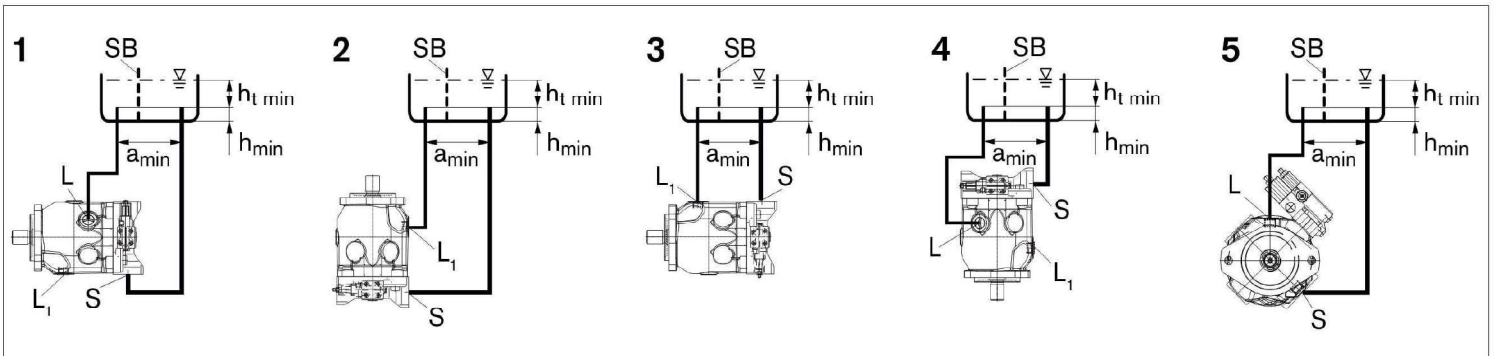

❑ Annotation:

- L, L₁ Highest case drain port
- S Suction port
- SB Baffle (baffle plate)
- h_{t min} Minimum required immersion depth (200 mm)
- h_{min} Minimum required spacing to reservoir bottom (100 mm)
- When designing the reservoir, ensure adequate space between the suction line and the drain line. This prevents the heated, return flow from being drawn directly back into the suction line.

❑ Below-reservoir installation:

Installation Position	Air bleed	Filling
1 (drive shaft, horizontal)	L	S+L
2 (drive shaft vertically upward)	L ₁	S+ L ₁
3 (drive shaft, horizontal)	L ₁	S+ L ₁
4 (drive shaft, vertically downward)	L	S+L
5 (drive shaft, horizontal)	L	S+L

■ Inside-reservoir installation:

- Inside-reservoir installation is when the axial piston unit is installed in the reservoir below the minimum fluid level.
- If the minimum fluid level is equal to or below the upper edge of the pump, see "Above-reservoir installation".
- When the min. Fluid level is lower than the flange height of pump in the front, port L₁ and port S can be opened, while port L must be plugged, but we recommend to fit a suction pipe to the suction port S and and to fit a pipe to case drain port L₁.
- When the min. Fluid level is lower than the flange height of pump in the front, port L and port L₁ must be connected by pipelines, The distance between two ports is longer than 200mm, please refer to Above-reservoir installation.

■ Risk of damage with inside-reservoir installation!

- To prevent damage to the axial piston unit, all plastic parts (e.g. protective plugs, covers) must be removed prior to installation in the reservoir.
- ✚ Remove all plastic parts before installing the axial piston unit in the reservoir. Make sure that no pieces of these parts remain in the reservoir.
- Axial piston units with electric components (e.g. electric controls, sensors) must not be installed in a reservoir below the fluid level.
- Before install pipelines, the axial piston pump must be filled with hydraulic oil and fuel tank filled with hydraulic oil too.

□ Inside-reservoir installation with installation position 6–10

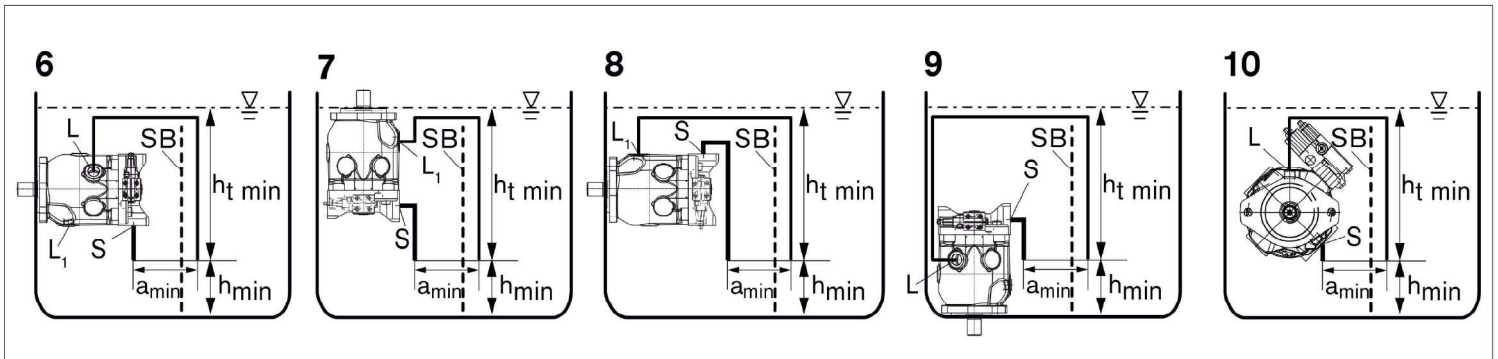

□ Annotation:

- L, L₁ Highest case drain port
- S Suction port
- SB Baffle (baffle plate)
- h_{t min} Minimum required immersion depth (200 mm)
- h_{min} Minimum required spacing to reservoir bottom (100 mm)
- a_{min} When designing the reservoir, ensure adequate space between the suction line and the drain line. This prevents the heated, return flow from being drawn directly back into the suction line.

□ Inside-reservoir installation:

Installation Position	Air bleed	Filling
1 (drive shaft, horizontal)	L	L
2 (drive shaft vertically upward)	L ₁	L ₁ +S
3 (drive shaft, horizontal)	L ₁	L ₁ +S
4 (drive shaft, vertically downward)	L	L +S
5 (drive shaft, horizontal)	L	L

■ Above-reservoir installation:

- Above-reservoir installation means the axial piston unit is installed above the minimum fluid level of the reservoir.
- To prevent the axial piston unit from draining, a height difference $h_{ES\ min}$ of at least 25 mm at port L 1 is required in installation position 12.
- The permissible suction height h_s is derived from the total pressure loss. The maximum permissible suction height $h_{s\ max} = 800\ mm$, The minimum required immersion depth $h_{t\ min} \geq 200\ mm$
- In static or dynamic case, the minimum inlet pressure of the pump $P_{in\ min}$ (suction pressure) must be not less than 0.8 bar absolute pressure
- The check valve in the case drain line is only allowed in individual cases, any information about certification, please consult us.
- To achieve the low noise operation, should avoid the pump above the oil tank.

■ Risk of damage with inside-reservoir installation!

- The air accumulating in the bearing area will damage the axial piston pump.
- ✚ For the "drive shaft up" installation position, filling and air bleeding must be carried out completely in the pump during commissioning and operating process.
- During commissioning and operating process, make sure the suction line is always filled with hydraulic fluid.

□ Above-reservoir installation with installation position 11–15

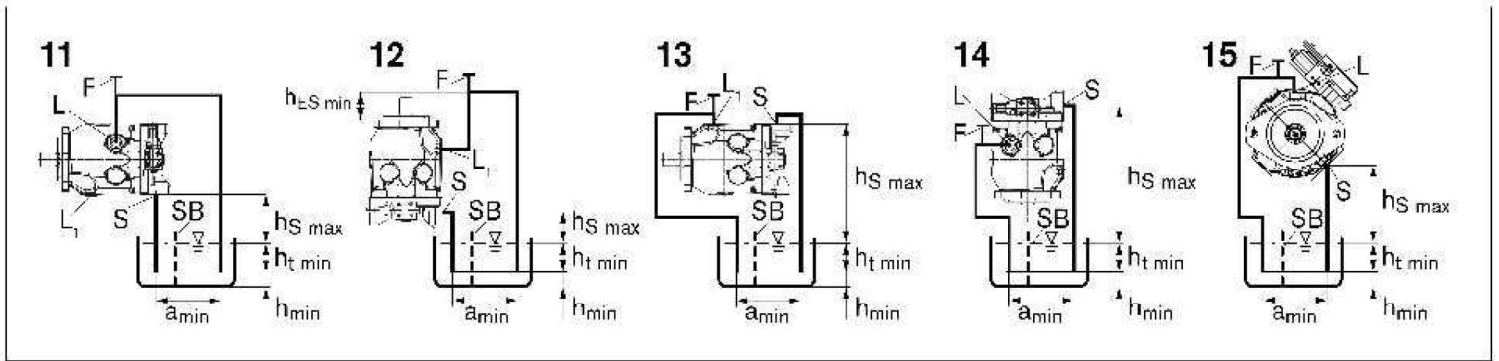

□ Annotation:

- L, L₁ Highest case drain port
 - S Suction port
 - SB Baffle (baffle plate)
 - $h_{s\ max}$ Maximum permissible suction height
 - $h_{t\ min}$ Minimum required immersion depth (200 mm)
 - h_{min} Minimum required spacing to reservoir bottom (100 mm)
 - $h_{ES\ min}$ Minimum necessary height to provide protection against the axial piston unit running dry (25 mm)
- When designing the reservoir, ensure adequate space between the suction line and the drain line. This prevents the heated, return flow from being drawn directly back into the suction line.

□ Above-reservoir installation:

Installation Position	Air bleed	Filling
1 (drive shaft, horizontal)	F	L (F)
2 (drive shaft vertically upward)	F	L ₁ (F)
3 (drive shaft, horizontal)	F	L ₁ (F)
4 (drive shaft, vertically downward)	F	L (F)
5 (drive shaft, horizontal)	F	L (F)

■ Installing the axial piston unit:

■ Preparation:

1. Check the delivery contents for completeness and transport damages.
2. Compare the material number and designation (ordering code) with the details in the order confirmation.
3. Before installation, completely empty the axial piston unit to prevent mixing with the hydraulic fluid used in the machine/system.
4. Check the direction of rotation of the axial piston unit (on the name plate) and make sure that this corresponds to the direction of rotation of the engine.

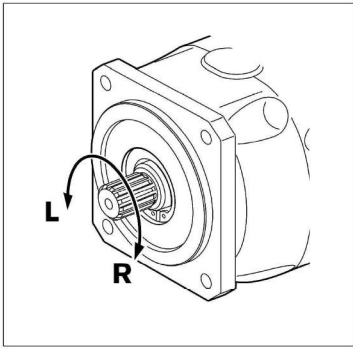

- Direction of rotation L: L (Counter-clockwise) R (Clockwise)

■ Dimensions:

- The installation drawing contains the dimensions for all connections and ports on the axial piston unit. Also observe the manuals provided by the manufacturers of the other hydraulic components when selecting the required tools.

■ General instructions:

- During assembly (and disassembly) of the axial piston unit, observe the following general instructions and handling instructions:

✚ Note that you can expect certain installation positions to affect the control device. Because of gravity, dead weight and case pressure, minor characteristic displacements and actuating time changes may occur.

✚ After a short operating time, toothed belts lose a major portion of their pre-tension and thus cause speed variations and torsional vibrations. Torsional vibrations may cause leakages on the shaft seal or increased rotary angle accelerations of the rotary group of the axial piston unit. Particularly at risk are diesel drives with a small number of cylinders and low flywheel mass.

✚ V-belt drives without automatic clamber are also critical with regard to speed variations and torsional vibrations. These can also lead to leakages on the shaft seal ring. An automatic clamber can lessen the speed variations and vibrations and thus avoid consequential damage.

✚ On the input or output drive of an axial piston unit, a cardan shaft may cause vibrations and impermissible rotary angle accelerations. Depending on the frequency and temperature, they may result in leakage on the shaft seal and damage to the rotary group.

■ Note:

- Always use an automatic tensioning device when using toothed belts or V-belts to transfer the input or output drive.
- Fix the axial piston unit so that the expected forces and torques can be transferred without any danger.

- The permissible axial and radial loading of the drive shaft, the permissible torsional vibration, the optimum direction of load force, as well as the limit speeds can be found in the data sheet.

- Observe the permissible radial forces on the drive shaft when driving with radial loading (belt drives). If necessary, the belt pulley must be separately mounted.

■ Installation with coupling:

- The method for installing the axial piston unit with a coupling is described below:

1. The drive shaft of the axial piston unit is equipped with a threaded bore. Use this threaded bore to pull the coupling element onto the drive shaft. The size of the threaded bore can be seen in the installation drawing.
2. Remove dirt and contaminants from the installation location.
3. Clamp the coupling hub onto the drive shaft or ensure permanent lubrication of the drive shaft. This prevents the formation of frictional corrosion and the associated wear.
4. Transport the axial piston unit to the installation location. The axial piston unit may not be bolted down until the coupling has been correctly installed.
5. Install the coupling on the drive shaft of the machine/system in accordance with the specifications provided by the coupling manufacturer.
6. Fix the axial piston unit at the installation location.
7. Align the drive shaft of the axial piston unit and the drive shaft of the machine or system so that there is no angular deviation.
8. Make sure that no impermissible axial and radial forces act on the drive shaft.
9. For bell housing installation, check the coupling axial play through the bell window according to the manufacturer's instructions.
10. Details on the required tools and tightening torques for the fixing screws are available from the machine/system manufacturer.
11. When using flexible couplings, check that the output drive is free of resonance after completing the installation.

■ Installation on a gearbox:

- The installation layout for the axial piston unit on a gearbox is described below:

- After installing on a gearbox, the axial piston unit is covered and is difficult to access.

- Therefore, before installing, make sure that the centering spigot centers the axial piston unit (observe tolerances) and that no impermissible axial or radial forces act on the drive shaft of the axial piston unit (installation length).

- Protect the drive shaft against frictional corrosion by providing permanent lubrication.

- Fix the axial piston unit at the installation location.

■ Installation with cardan shaft

- To connect the axial piston unit to the engine via a cardan shaft:

1. Position the axial piston unit close to the specified installation location. It should allow enough space for the cardan shaft to fit through on both sides.
2. Position the cardan shaft on the output shaft of the engine.
3. Push the axial piston unit to the cardan shaft and join the cardan shaft to the drive shaft of the axial piston unit.
4. Bring the axial piston unit to the installation position and secure. Details on the required tools and breakaway torques for the fixing screws can be obtained from the system manufacturer if required.

■ Completing installation:

1. Remove any mounted transport screws
2. Remove the transport protection

The axial piston unit is delivered with protective covers and protective plug. They are not pressure-resistant, therefore they have to be removed prior to connection.

3. Make certain that the sealing and functional surfaces are not damaged.

4. For versions with through drive, assemble the auxiliary pump according to the pump manufacturer's instructions.

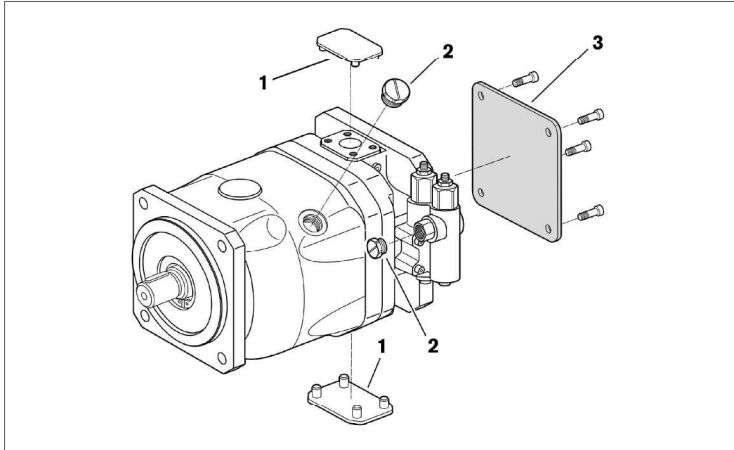

- Removing transport protection:
 1. Transport protection for shaft end
 2. Protective covers
 3. Plastic plugs / locking screws
 4. Flange cover and fixing screws (optional for versions with through drive)

■ Hydraulically connecting the axial piston unit:

- The machine/system manufacturer is responsible for dimensioning the lines.
- The axial piston unit must be connected to the rest of the hydraulic system in accordance with the hydraulic circuit diagram of the machine/system manufacturer.
- The ports and fixing threads are designed for the maximum pressure specified in the data sheet. The machine/system manufacturer must ensure that the connecting elements and lines correspond to the specified application conditions (pressure, flow, hydraulic fluid, temperature) with the necessary safety factors.

■ Warning! Insufficient suction pressure! !

- Generally, a minimum permissible suction pressure at port S is specified for axial piston pumps in all installation positions. If the pressure at port S drops below the specified values, damage may occur which may lead to the axial piston pump being damaged beyond repair!

- Make sure that the necessary suction pressure is not undercut.

This is influenced by:

- ✚ the piping suction cross-section
- ✚ the pipe diameter, length of suction line
- ✚ the position of the reservoir
- ✚ the viscosity of the hydraulic fluid
- ✚ if fitted, a filter cartridge or check valve in the suction line (regularly check the level of soiling of the filter cartridge)

■ Notes on routing the lines

- Observe the following notes when routing the suction, pressure and reservoir lines.:
 - ✚ Lines and hoses must be installed without pre-charge pressure, so that no further mechanical forces are applied during operation that will reduce the service life of the axial piston unit and, if applicable, the entire machine/system.
 - ✚ Use suitable seals as sealing material.
- Suction line (pipe or hose):
 - ✚ The suction line should be as short and straight as possible.
 - ✚ Measure the line cross section of the suction line so that the pressure at the suction port does not drop below the minimum permissible pressure. Make sure that the maximum suction pressure is not exceeded (e.g. when prefilling).
 - ✚ Make sure the connections and connecting elements are air-tight.
- Pressure line:
 - ✚ For the pressure lines, use only pipes, hoses and connecting elements rated for the operating pressure range specified in data sheets.
- Drain line
 - ✚ Always route the reservoir lines so that the case is constantly filled with hydraulic fluid and to ensure that no air gets through the shaft seal even during extended standstill periods.
 - ✚ The case internal pressure must not exceed the limit values listed for the axial piston unit in the data sheet under any operating conditions.
 - ✚ The reservoir line joint in the reservoir must always be below the minimum fluid level under all conditions.
- Procedure
 - To connect the axial piston unit to the hydraulic system:
 1. Remove the locking screws at the ports at which the connections are to be made according to the hydraulic circuit diagram.
 2. Use only clean hydraulic lines.
 3. Connect the lines according to the hydraulic circuit diagram. Either pipes or hoses must be connected to all ports according to the installation drawing and machine or system circuit diagram or the ports plugged using suitable locking screws.
 4. Make sure
 - ✚ that the cap nuts are correctly tightened on the fittings and flanges (observe tightening torques!). Mark all checked fittings using e.g. a permanent marker
 - ✚ that the pipes and hose lines and every combination of connecting piece, coupling or connecting point with hoses or pipes have been inspected by a technically qualified person for safe working condition.

■ Port overview:

□ Port overview AH10V(S)O

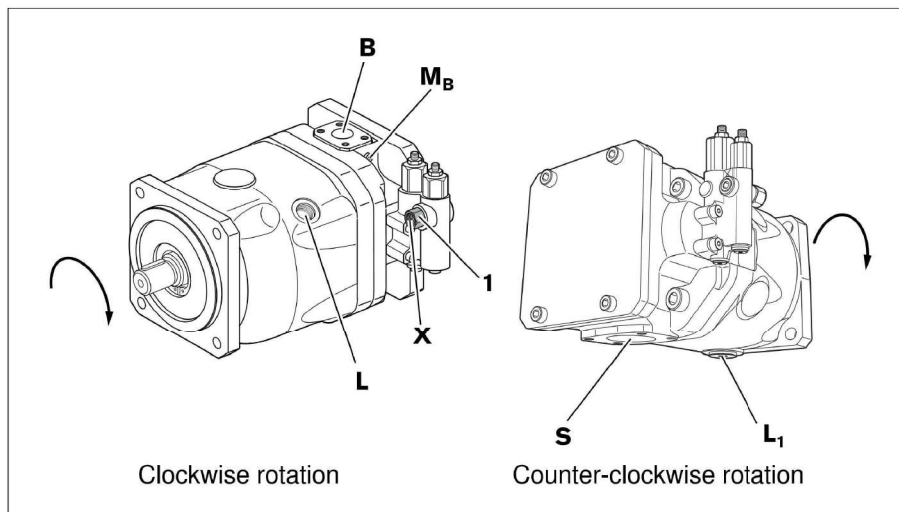

□ Ports AH10VSO Series 31:

Designation	Port for	Standard	Maximum Pressure bar ¹⁾	State
B	Service line (High-speed version) Fixing threads	SAE J518 ²⁾ DIN 13	350	O
S	Suction line Fixing threads	SAE J518 ²⁾ DIN 13	1	O
L	Reservoir line (case drain fluid)	DIN 3852 ³⁾	2	O ⁴⁾
L ₁	Reservoir line (case drain fluid)	DIN 3852 ³⁾	2	X ⁴⁾
X	Pilot pressure...DRG,DRF,DRS,LA	DIN 3852 ³⁾	350	O
X	Pilot pressure...DG	DIN ISO 228 ³⁾	350	O
M _B	Gauge port	DIN 3852 ³⁾		X

□ Ports AH10VO Series 52:

Designation	Port for	Standard	Maximum Pressure bar ¹⁾	State
B	Service line (High-speed version) Fixing threads	SAE J518 ²⁾ DIN 13	350	O
S	Suction line Fixing threads	SAE J518 ²⁾ DIN 13	1	O
L	Reservoir line (case drain fluid)	DIN 3852 ³⁾	2	O ⁴⁾
L ₁	Reservoir line (case drain fluid)	DIN 3852 ³⁾	2	X ⁴⁾
X	Pilot pressure...DRG,DRF,DRS,LA	DIN 3852 ³⁾	350	O
X	Pilot pressure...DG	DIN ISO 228 ³⁾	350	O

1) Short-term pressure spikes may occur depending on the application. Keep this in mind when selecting measuring devices and fittings. Pressure data in bar absolute.

2) Metric fixing thread, deviating from standard.

3) The countersink may be deeper than specified in the standard.

4) Depending on the installation position, L or L₁ must be connected.

O = Must be connected (plugged on delivery)

X = Plugged (in normal operation)

■ Tightening torques:

- Threaded hole of the axial piston unit:
The maximum permissible tightening torques $M_{G \text{ max}}$ are maximum values of the female threads and must not be exceeded. For values, see the following table.
- Fittings:
Observe the manufacturer's instructions regarding the tightening torques of the fittings used.
- Fixing screws:
For fixing screws with metric ISO thread according to DIN 13 or with thread according to ASME B1.1, we recommend checking the tightening torque in individual cases as per VDI 2230.
- Threaded plugs:
For the metallic threaded plugs supplied with the axial piston unit, the required tightening torques of threaded plugs M_V apply. For values, see the following table.

■ Risk of mix-ups with threaded connections:

- The axial piston units are used in application areas with metric as well as with Imperial systems of units.
- Both the system of units as well as the size of threaded hole and threaded plug (e.g. locking screw) must match.
 - If a threaded plug which is of a different measurement system and size with respect to the female thread is pressurized, the threaded plug may loosen itself or even be ejected from the hole in a projectile-like manner. This can result in serious injury and damage to equipment. Hydraulic fluid can be discharged from this leakage point.
 - ✚ Use the drawings (installation drawing/data sheet) to determine the required threaded plug for each fitting.
 - ✚ Make sure that there are no mix-ups when installing fittings, fixing screws and threaded plugs.
 - ✚ For all female threads, use a threaded plug from the same system of units and of the correct size.

■ Electrically connecting the axial piston unit:

- The machine/system manufacturer is responsible for the layout of the electric control.
- Electrically controlled axial piston units must be connected in accordance with the electrical circuit diagram for the machine/system.
- For axial piston units with electrical control and/or mounted sensors, please comply with the details given in data sheets, e.g.:
 - ✚ the permissible voltage range and the permissible current
 - ✚ the recommended electrical control units
- Exact details on the connector, type of protection and matching mating connector can also be found in data sheets. The mating connector is not included in the delivery contents.
 1. Switch off power supply to the relevant system component.
 2. Electrically connect the axial piston unit (12 or 24V). Before connection, check that the connector including all seals are intact.

■ NOTE: Short circuit in event of penetrating hydraulic fluid!

- Fluid can penetrate the product and cause a short circuit!
- Do not install axial piston units with electric components (e.g. electric controls, sensors) in a reservoir below the fluid level (inside-reservoir installation).

■ Tightening torques for the female threads and threaded plugs:

- Values for AH10VSO:

Ports		Maximum permissible tightening torque for female threads $M_{G \text{ max}}$	Required tightening torque for threaded plugs M_V	Size of hexagon socket of threaded plugs
Standard	Thread size			
DIN 3852	M14 x 1.5	80 Nm	35 Nm ¹⁾	6 mm
	M16 x 1.5	100 Nm	50 Nm ¹⁾	8 mm
	M18 x 1.5	140 Nm	60 Nm ¹⁾	8 mm
	M22 x 1.5	210 Nm	80 Nm ¹⁾	10 mm
	M27 x 2	330 Nm	135 Nm ¹⁾	12 mm
DIN ISO 228	G 1/4 in	70 Nm	–	–
ISO 11926	7/8-14 UNF-2B	240 Nm	110 Nm	3/8 in
	1 1/16-12 UNF-2B	360 Nm	170 Nm	9/16 in

1) The tightening torques of the threaded plugs M_V apply for screws in the "dry" state as received on delivery and in the "lightly oiled" state for installation

□ Values for AH10VO:

Ports		Maximum permissible tightening torque for female threads $M_{G \max}$	Required tightening torque for threaded plugs M_V	Size of hexagon socket of threaded plugs
Standard	Thread size			
DIN 3852	M14 x 1.5	80 Nm	45 Nm	6 mm
	M16 x 1.5	100 Nm	50 Nm	8 mm
	M27 x 2	330 Nm	170 Nm	12 mm
ISO 11926	7/16-20UNF-2B	40 Nm	18 Nm	3/16 in
	9/16-18UNF-2B	80 Nm	35 Nm	1/4 in
	3/4-16UNF-2B	160 Nm	70 Nm	5/16 in
	7/8-14UNF-2B	240 Nm	110 Nm	3/8 in
	1 1/16-12UN-2B	360 Nm	170 Nm	9/16 in

■ First commissioning

■ Filling the axial piston unit

□ You will require an approved hydraulic fluid:

✚ The machine or system manufacturer can provide you with precise details on the hydraulic fluid. Details on minimum requirements for mineral-oil based hydraulic fluids, environmentally acceptable hydraulic fluids or HF hydraulic fluids for the axial piston unit are available.

✚ To ensure the functional reliability of the axial piston unit, cleanliness level 20/18/15 according to at least ISO 4406 is necessary for the hydraulic fluid. For permissible temperatures, see the data sheet.

1. Place a drip tray under the axial piston unit to collect any hydraulic fluid that may escape.
2. Fill and air bleed the axial piston unit via the appropriate ports, see chapter "Installation position". The hydraulic lines of the system must also be filled.
3. When using a shut-off valve in the suction and/or reservoir line, make sure that the input of the axial piston unit can only be started when the shut-off valves are open.
4. Test the direction of rotation of the engine. To do this, rotate the engine briefly at the lowest rotational speed (inching). Make sure that direction of rotation of the axial piston unit matches the details on the name plate.
5. Operate the axial piston pump at a lower speed (starter speed for internal combustion engines or inching operation for electric motors) until the hydraulic system is completely filled and bled. To inspect, drain the hydraulic fluid at the case drain port and wait until it drains without bubbles.
6. Make sure that all ports are either connected to pipes or plugged according to the general circuit diagram.

■ Testing the hydraulic fluid supply:

1. The axial piston unit must always have a sufficient supply of hydraulic fluid.
2. For this reason, the supply of hydraulic fluid must be ensured at the start of the commissioning process.
3. When you test the hydraulic fluid supply, constantly monitor the noise development and check the hydraulic fluid level in the reservoir. If the axial piston unit becomes louder (cavitation) or the case drain fluid is discharged with bubbles, this is an indication that the axial piston unit is not being sufficiently supplied with hydraulic fluid.

□ Notes on troubleshooting can be found in "Troubleshooting".

□ To test the hydraulic fluid supply:

1. Allow the engine to run at the lowest speed. The axial piston unit must be operated without load. Pay attention to leakage and noise.
2. Check the axial piston unit's reservoir line during the test. The case drain fluid should not contain any bubbles.
3. Increase the load and check whether the operating pressure rises as expected.
4. Carry out a leak test to ensure that the hydraulic system is sealed and can withstand the maximum pressure.
5. Check the suction pressure at port S of the axial piston pump at nominal speed and maximum swivel angle. Refer to data sheet for the permissible value.
6. At maximum pressure, check the case drain pressure at port L or L₁. Refer to data sheet for the permissible value.

■ Performing functional test

□ Once you have tested the hydraulic fluid supply, you must perform a functional test on the machine or system. The functional test should be performed according to the instructions of the machine or system manufacturer.

□ The axial piston unit is checked for functional capability before delivery according to the technical data. During commissioning, it must be ensured that the axial piston unit was installed in accordance with the design of the machine or system.

✚ Use the swivel angle indicator to check whether the axial piston unit swivels in and out correctly during operation.

✚ If necessary, disconnect the gage and plug the ports with threaded plugs.

■ Performing flushing cycle

□ In order to remove foreign bodies from the system, supplier recommends a flushing cycle for the entire system.

□ The axial piston unit must not be included in the flushing cycle.

□ The flushing cycle must be performed with an additional flushing unit.

□ Follow the instructions of the flushing unit's manufacturer for the exact procedure during the flushing cycle.

■ Recommissioning after standstill:

□ Depending on the installation conditions and ambient conditions, changes may occur in the hydraulic system which make recommissioning necessary.

□ the following criteria may make recommissioning necessary:

✚ Air and/or water in the hydraulic system

✚ Other contamination

□ Before recommissioning, proceed as "First commissioning" .

■ Running-in phase

□ The increased friction at the start of the running-in phase results in increased heat development which decreases with increasing operating hours. The volumetric and mechanical-hydraulic efficiency increases as well through the conclusion of the running-in phase of approx. 10 operating hours.

□ To ensure that contamination in the hydraulic system does not damage the axial piston unit, recommend the following procedure after the running-in phase:

✚ After the running-in phase, have a hydraulic fluid specimen analyzed for the required cleanliness level.

✚ Change the hydraulic fluid if the required cleanliness level is not reached. If a laboratory test is not carried out after the running-in phase, recommend the hydraulic fluid be changed .

■ Damage to equipment by insufficient viscosity!

□ An increased hydraulic fluid temperature may reduce the viscosity values by too much and damage the product!

✚ Monitor the operating temperature during the running-in phase

✚ Reduce the loading (pressure, rpm) of the axial piston unit if impermissible operating temperatures and/or viscosities occur.

■ Operation:

□ The product is a component which requires no settings or changes during operation. For this reason, this chapter of the manual does not contain any information on adjustment options. Only use the product within the performance range provided in the technical data.

□ The machine or system manufacturer is responsible for the proper project planning of the hydraulic system and its control.

■ **Cleaning and care**

- ❑ For cleaning and care of the axial piston unit, observe the following:
 - ✚ Plug all openings with suitable protective caps/devices.
 - ✚ Check whether all seals and plugs of the plug connections are securely seated to ensure that no moisture can penetrate into the axial piston unit during cleaning.
 - ✚ Use only water and, if necessary, a mild detergent to clean the axial piston unit. Never use solvents or aggressive detergents.
 - ✚ Remove coarse external dirt and keep sensitive and important components, such as solenoids, valves, indicators and sensors, clean.

■ **Inspection:**

- ❑ In order to enable long and reliable operation of the axial piston unit, recommend testing the hydraulic system and axial piston unit on a regular basis, and documenting and archiving the following operating conditions:
- ❑ Inspection schedule:

Task to be carried out		Interval
Hydraulic system	Check level of hydraulic fluid in the reservoir.	Daily
	Check the operating temperature at a comparable load condition at the reservoir port and in the reservoir.	Weekly
	Conduct analysis of hydraulic fluid: viscosity, aging and dirt contamination.	Yearly or every 2000 operating hours (whichever occurs first)
Axial piston unit	Check axial piston unit for leakage. Early detection of hydraulic fluid loss can help to find errors on the machine/system and to rectify them. For this reason, recommend that the axial piston unit and system are always kept in a clean condition.	Daily
	Check axial piston unit for unusual noise development.	Daily
	Check fasteners for tight seating. All fasteners have to be checked when the hydraulic system is switched off, depressurized and cooled down.	Monthly

■ **Maintenance**

- ❑ The axial piston unit is low maintenance when used properly.
- ❑ The service life of the axial piston unit is heavily dependent on the quality of the hydraulic fluid. For this reason, we recommend changing the hydraulic fluid at least once per year or every 2000 operating hours (which ever occurs first) or having it analyzed by the hydraulic fluid manufacturer or a laboratory to determine its suitability for further use.
- ❑ The service life of the axial piston unit is limited by the service life of the bearings fitted. The service life can be requested on the basis of the load cycle from the responsible Service partner.
- ❑ Based on these details, a maintenance period is to be determined by the system manufacturer for the replacement of the bearings and included in the maintenance schedule of the hydraulic system.

■ **Repair:**

- ❑ Repairs on the axial piston unit may only be performed by service centers certified by supplier, and use exclusively original spare parts
- ❑ Tested and pre-assembled original assembly groups allow for successful repair requiring only little time

Spare parts:

- ❑ The list of spare parts for axial piston units are order specific. When ordering spare parts, please quote the material and serial number of the axial piston unit as well as the material numbers of the spare parts.
- ❑ Please address all questions regarding spare parts to your responsible huade Service partner or the service department of the manufacture's plant for the axial piston unit.

■ **Troubleshooting:**

- ❑ The following table may assist you in troubleshooting. The table makes no claim for completeness.
- ❑ In practical use, problems which are not listed here may also occur.
- **How to proceed for troubleshooting:**
 - ❑ Always act systematically and purposefully, even under pressure of time. Random and imprudent removal and changing of settings could result in the inability to ascertain the original failure cause.
 - ❑ First obtain a general overview of how your product works in conjunction with the entire system.
 - ❑ Try to determine whether the product worked properly in conjunction with the entire system before the error occurred.
 - ❑ Try to determine any changes of the entire system in which the product is integrated:
 - ✚ Were there any changes to the product's application conditions or operating range??
 - ✚ Has maintenance work recently been carried out? Is there an inspection or maintenance log?
 - ✚ Were changes (e.g. conversions) or repairs made to the complete system (machine/system, electrics, control) or on the product? If yes, which?
 - ✚ Has the hydraulic fluid been changed?
 - ✚ Was the product or machine operated as intended?
 - ✚ How did the malfunction appear?
 - ❑ Try to get a clear idea of the error cause. Directly ask the (machine) operator.
 - ❑ Document the work carried out.

■ Axial piston unit malfunction table:

Fault	Possible cause	Remedy
Unusual noises	Drive speed too high.	Machine/system manufacturer.
	Wrong direction of rotation.	Ensure correct direction of rotation.
	Insufficient suction conditions, e.g. air in the suction line, insufficient diameter of the suction line, viscosity of the hydraulic fluid too high, suction height too high, suction pressure too low, contaminants in the suction line.	Machine or system manufacturer (e.g. optimize inlet conditions, use suitable hydraulic fluid).
		Completely air bleed axial piston unit, fill suction line with hydraulic fluid.
		Remove contaminants from the suction line.
	Improper fixing of the axial piston unit.	Check the fixing of the axial piston unit according to the specifications of the machine/ system manufacturer. Observe tightening torques.
	Improper fixing of the attachment parts, e.g. coupling and hydraulic lines.	Fix attachment parts according to the information provided by the coupling or fitting manufacturer.
	Pressure relief valves on axial piston unit	Air bleed axial piston unit Check viscosity of the hydraulic fluid Contact Service.
Mechanical damage to the axial piston unit (e.g. bearing damage).	Exchange axial piston unit, contact Service.	
No or insufficient flow	Faulty mechanical drive (e.g. defective coupling).	Machine or system manufacturer.
	Drive speed too low.	Machine or system manufacturer.
	Insufficient suction conditions, e.g. air in the suction line, insufficient diameter of the suction line, viscosity of the hydraulic fluid too high, suction height too high, suction pressure too low, contaminants in the suction line.	Machine or system manufacturer (e.g. optimize inlet conditions, use suitable hydraulic fluid).
		Completely air bleed axial piston unit, fill suction line with hydraulic fluid.
		Remove contaminants from the suction line.
	Hydraulic fluid not in optimum viscosity range.	Use suitable hydraulic fluid (machine or system manufacturer).
	External control of the control device defective.	Check external control (machine or system manufacturer).
	Insufficient pilot pressure or control pressure..	Check pilot pressure, contact Service.
	Malfunction of the control device or controller of the axial piston unit.	Contact Service.
	Wear of axial piston unit.	Exchange axial piston unit, contact Service.
Mechanical damage to the axial piston unit.	Exchange axial piston unit, contact Service.	
No or insufficient pressure	Faulty mechanical drive (e.g. defective coupling).	Machine or system manufacturer.
	Drive power too low.	Machine or system manufacturer.
	Insufficient suction conditions, e.g. air in the suction line, insufficient diameter of the suction line, viscosity of the hydraulic fluid too high, suction height too high, suction pressure too low, contaminants in the suction line.	Machine or system manufacturer (e.g. optimize inlet conditions, use suitable hydraulic fluid).
		Completely air bleed axial piston unit, fill suction line with hydraulic fluid.
		Remove contaminants from the suction line.
	Hydraulic fluid not in optimum viscosity range.	Use suitable hydraulic fluid (machine or system manufacturer).
	External control of the control device defective.	Check external control (machine or system manufacturer).
	Insufficient pilot pressure or control pressure.	Check pilot pressure, contact Service.
	Malfunction of the control device or controller of the axial piston unit.	Contact Service.
	Wear of axial piston unit.	Exchange axial piston unit, contact Service.
	Mechanical damage to the axial piston unit (e.g. bearing damage).	Exchange axial piston unit, contact Service.
Output unit defective (e.g. hydraulic motor or cylinder).	Machine or system manufacturer.	
Pressure/flow fluctuations	Axial piston unit not or insufficiently air bled.	Completely air bleed axial piston unit.
	Insufficient suction conditions, e.g. air in the suction line, insufficient diameter of the suction line, viscosity of the hydraulic fluid too high, suction height too high, suction pressure too low, contaminants in the suction line.	Machine or system manufacturer (e.g. optimize inlet conditions, use suitable hydraulic fluid).
		Completely air bleed axial piston unit, fill suction line with hydraulic fluid.
		Remove contaminants from the suction line.
Excessive hydraulic fluid temperature and case temperature	Excessive inlet temperature at the axial piston unit.	Machine or system manufacturer: inspect system, e.g. malfunction of the cooler, insufficient hydraulic fluid in the tank.
	Malfunction of the pressure control valves (e.g. high-pressure relief valve, pressure cut-off, pressure control).	Contact Service.
	Wear of axial piston unit.	Exchange axial piston unit, contact Service
Instability/vibrations	Target value not stable.	Machine/system manufacturer.
	Resonance in the reservoir line. Machine/system manufacturer.	Machine/system manufacturer.
	Malfunction of the control devices or the controller.	Contact Service.